



ROHINI

COLLEGE OF ENGINEERING & TECHNOLOGY

Approved by AICTE and Affiliated to Anna University, (An ISO Certified Institution)



ME 8791 MECHATRONICS

DEPARTMENT OF
MECHANICAL ENGINEERING

UNIT - I

INTRODUCTION

MECHATRONICS:

It field of study that implies the synergistic integration of electronic engineering, electrical engineering, control engineering and computer technology with mechanical engineering for the design, manufacture, analyses and maintenance of a wide range of engineering products and processes".

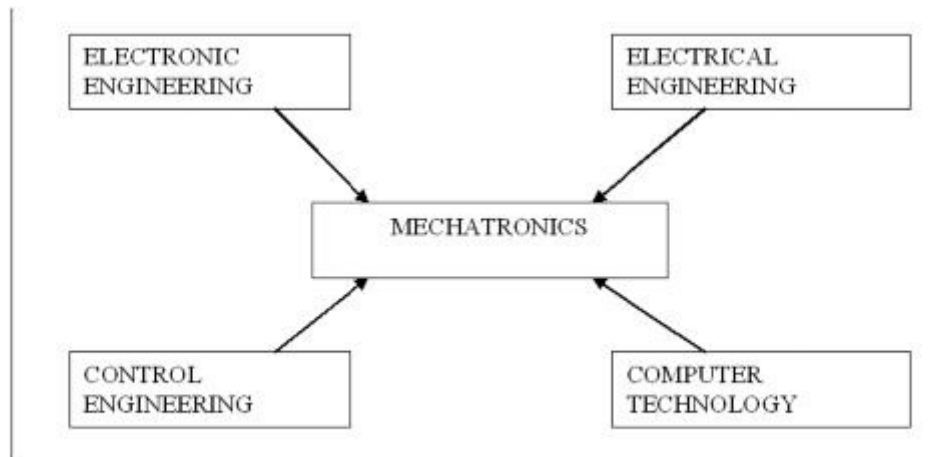

SYSTEM:

A system may be defined as a black box which has an input and an output. System concerned only with the relationship between the input and output and not on the process going inside the box.

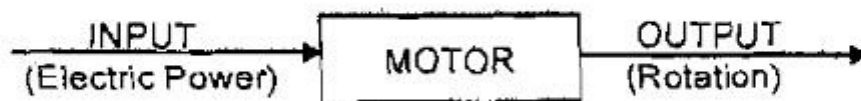

Here, the input is the electric power and the output after processed by the system is rotation. The system is motor.

MECHATRONIC SYSTEM:

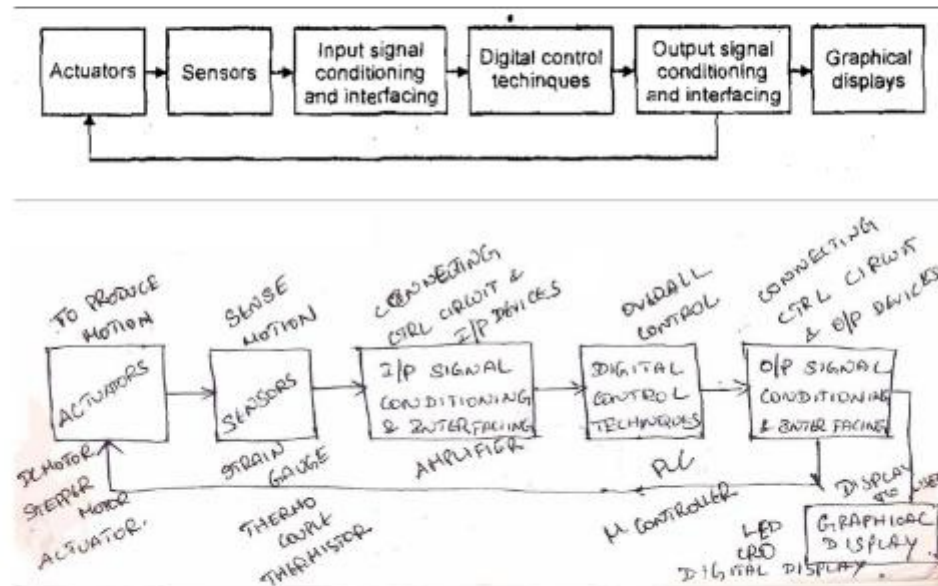

- **Actuators:** Solenoids, voice coils, D.C. motors, Stepper motors, Servomotor, hydraulics, pneumatics.
- **Sensors:** Switches, Potentiometer, Photoelectrics, Digital encoder, Strain gauge, Thermocouple, accelerometer etc.
- **Input signal conditioning and interfacing:** Discrete circuits, Amplifiers, Filters, A/D, D/D.
- **Digital control architecture:** Logic circuits, Microcontroller, SBC, PLC, Sequencing and timing, Logic and arithmetic, Control algorithm, Communication.
- **Output signal conditioning and interfacing:** D/A D/D, Amplifiers, PWM, Power transistor, Power Op - amps.

- **Graphical displays:** LEDs, Digital displays, LCD, CRT
- The actuators produce motion or cause some action;
- The sensors detect the state of the system parameters, inputs and outputs;
- Digital devices control the system;
- Conditioning and interfacing circuits provide connection between the control circuit and the input/output devices;
- Graphical displays provide visual feedback to users.

MEASUREMENT SYSTEM:

A measurement system can be defined as a black box which is used for making measurements. It has the input as the quantity being measured and the output as a measured value of that quantity.

Example:

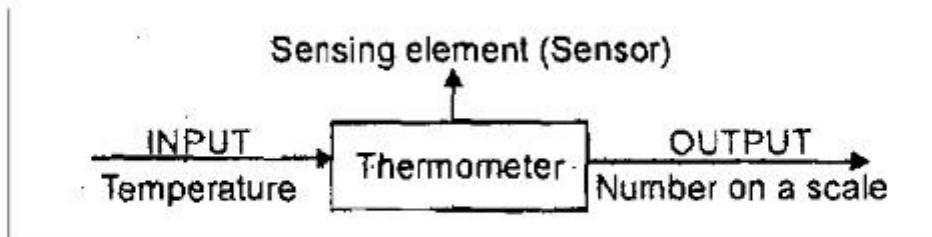

Elements of Measurement Systems:

Measurement system consists of the following three elements.

- a) Sensor b) Signal conditioner c) Display System**

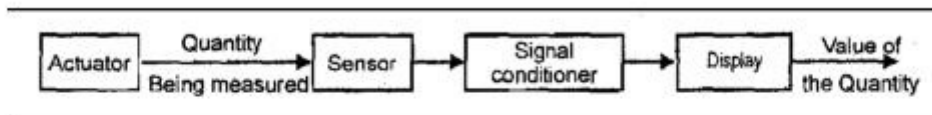

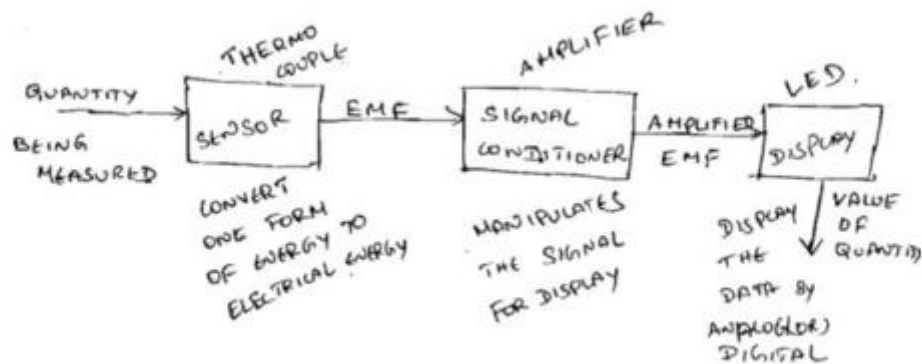

Sensor:

- A sensor consists of transducer whose function is to convert the one form of energy into electrical form of energy. A sensor is a sensing element of measurement system that converts the input quantity being measured into an output signal which is related to the quantity

Example:

- Temperature Sensor – Thermocouple
- Input – Temperature
- Output – E.M.F (Electrical Parameter).

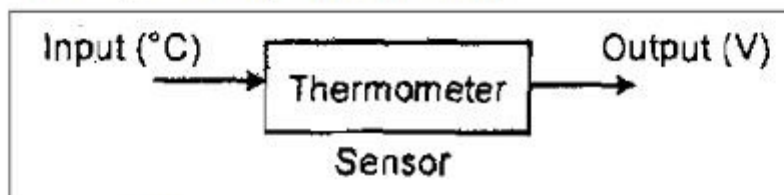

Signal Conditioner:

- A signal conditioner receives signal from the sensor and manipulates it into a suitable condition for display. The signal conditioner performs filtering, amplification or other signal conditioning on the sensor output.

Example:

- Temperature measurement – Single Conditioner function (Amplifier) Input – Small E.M.F value (From sensor)

- Output – Big E.M.F Value (Amplified).

Display System:

- A display system displays the data (output) from the signal conditioner by analog or digital. A digital system is a temporary store such as recorder.

Example:

- Display – L.E.D (or) Number on scale by pointer movement
- Input – Conditioned Signal (from signal conditioner)
- Output – Value of the quantity (Temperature)

Temperature Measurement System:

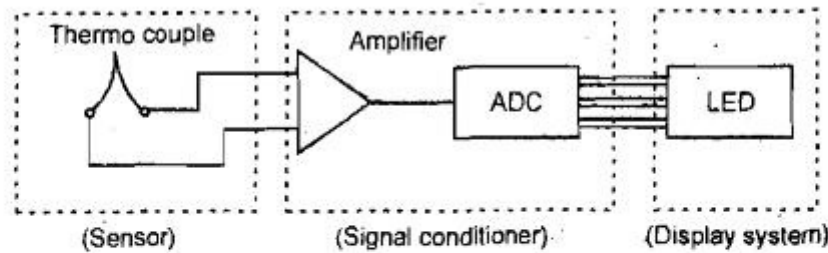

CONTROL SYSTEM:

A black box which is used to control its output in a pre-set value

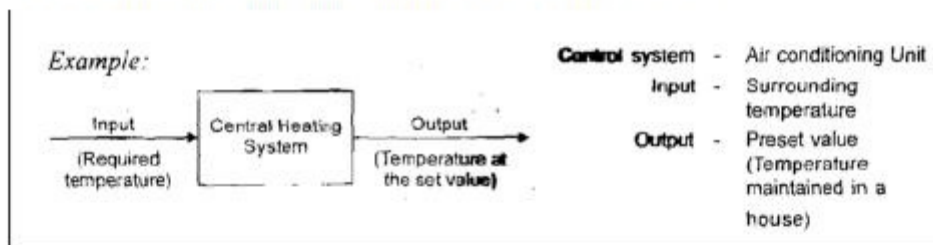

OPEN LOOP CONTROL SYSTEM:

If there is **no feedback** device to compare the actual value with desired one.

No control over its input

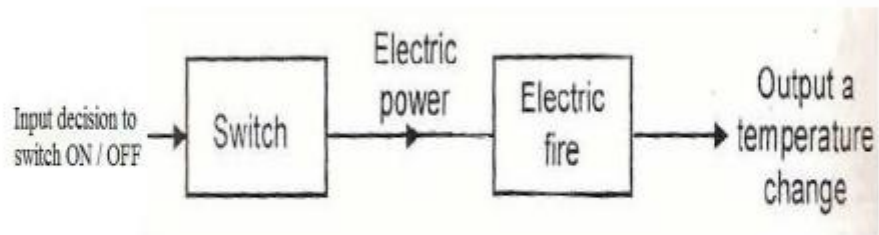

CLOSED LOOP CONTROL SYSTEM:

If there is **feedback** device to compare the actual value with desired one.

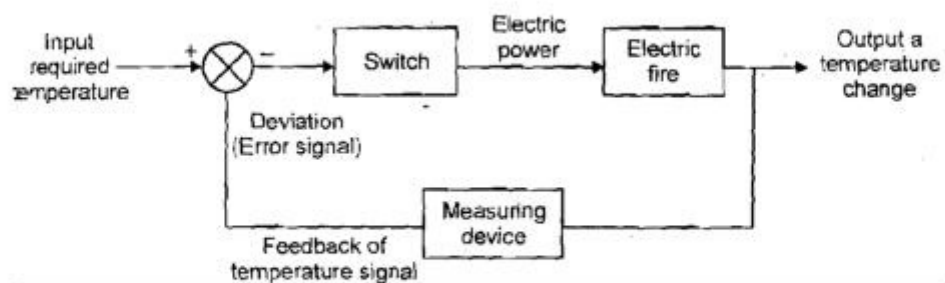

Elements of Closed Loop System:

The elements of closed loop control system are

- Comparison Unit
- Control Unit
- Correction Unit
- Process Unit
- Measurement Device

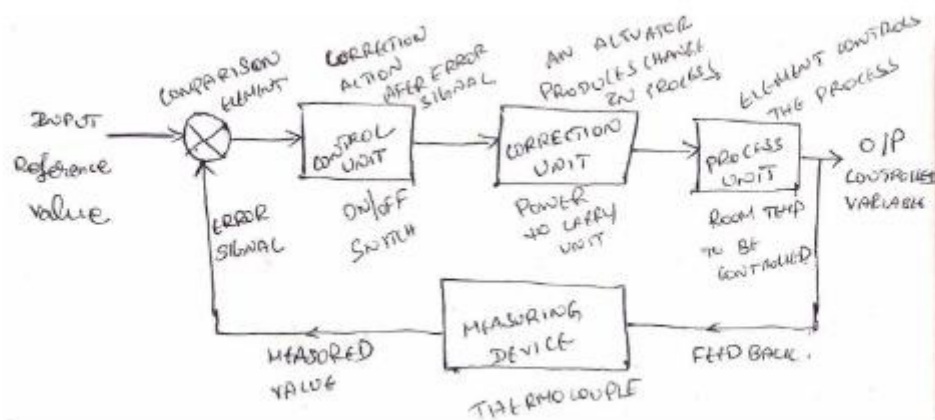

EXAMPLES:

System of Controlling Room Temperature

- Controlled Variable : Room temperature
- Reference Variable : Required Room temperature (pre-set value)
- Comparison Element : Person compares the measured value with required value
- Error Signal : Different between the measured and required temperatures.
- Control Unit : Person
- Correction Unit : The switch on the fire
- Process : Heating by the fire
- Measuring Device : Thermometer.

System of Controlling Water Level

- Controlled variable : Water level in the tank
- Reference variable : Initial setting of the float and lever position
- Comparison Element : The lever
- Error signal : Difference between the actual & initial setting of the lever positions
- Control Unit : The pivoted lever
- Correction Unit : The flap opening or closing the water supply

- Process : The water level in the tank
- Measuring device : The floating ball and lever

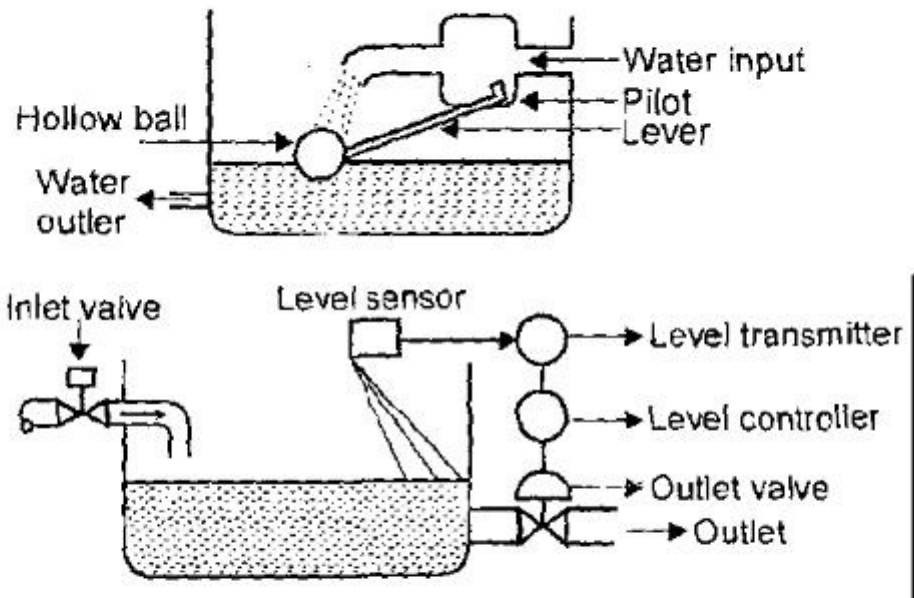

Automatic Speed Control of Rotating Shaft

- Potentiometer - To set the reference value (Voltage to be supplied to differential amplifier)
- Differential amplifier - To compare amplify the difference between the reference and feedback values
- Tachogenerator - To measure the speed of the rotating shaft and is connected to the rotating shaft by means of a pair of level gears.

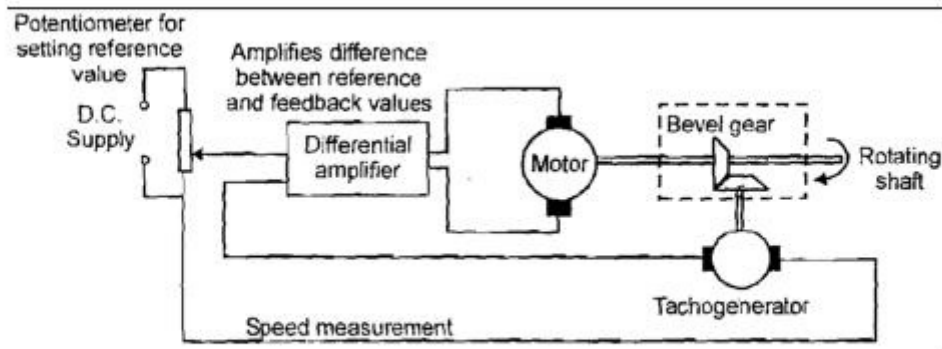

MICROPROCESSOR BASED CONTROLLERS:

SEQUENTIAL CONTROLLERS:

It is used to control the process that are strictly ordered in a time or sequence

DOMESTIC WASHING MACHINE:

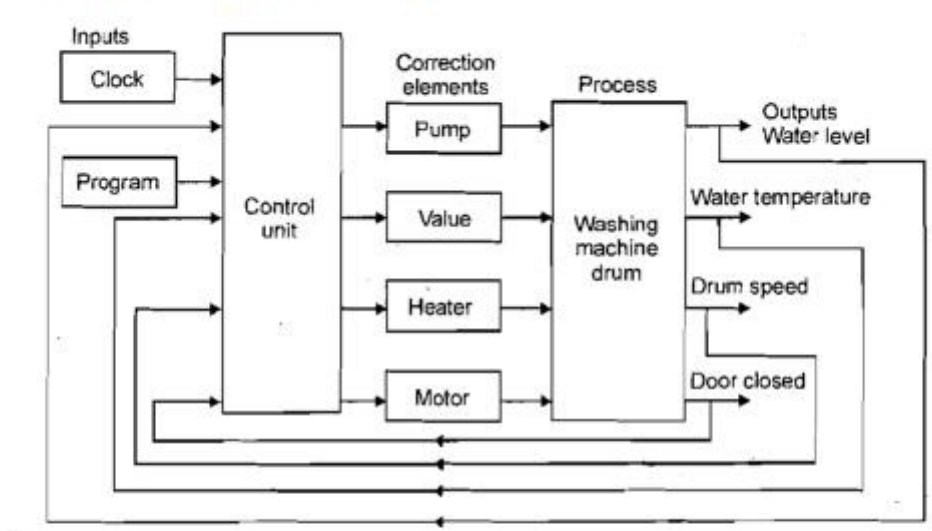

Pre Wash Cycle:

- Pre-wash cycle may involve the following sequence of operations.
- Opening of valve to fill the drum when a current is supplied
- Microprocessor is used to operate the switch for opening closing the valve.
- Closing the valve after receiving the signal from a sensor when the required level of water is filled in the washing drum.

- Stopping the flow of water after the current is switched off by the microprocessor.
- Switch on the motor to rotate for stipulated time.
- Initiates the operation of pump to empty the water from the drum.
- Pre-wash cycle involves washing the clothes in the drum by cold water.

Main Wash Cycle:

- Main wash cycle involves washing the clothes in the drum by hot water and the sequence of operations in main wash is as follows:
- Cold water is supplied after the Pre-wash cycle is completed.
- Current is supplied in large amount to switch on the heater for heating the cold water.
- Temperature sensor switches off the current after the water is heated to required temperature.
- Microprocessor or cam switch ON the motor to rotate the drum
- Microprocessor or cam switches on the current to a discharge pump to empty the drum.

Rinse Cycle:

- Rinse cycle involves washing out the clothes with cold water a number of times and the sequence of operations in a Rinse cycle are as follows:
- Opening of valve to allow cold water into the drum when the microprocessor are given signals to supply current after the main wash cycle is completed.
- Switches off the supply current by the signals from microprocessor
- Operation of motor to rotate the drum
- Operation of pump to empty the drum and repeat this sequence a number of times.

Spinning Cycle

Spinning cycle involves removing of water from the clothes and the sequence of operations is

- Switching on the drum motor to rotate it at a higher speed than a rinsing cycle.

AUTOMATIC CAMERA:

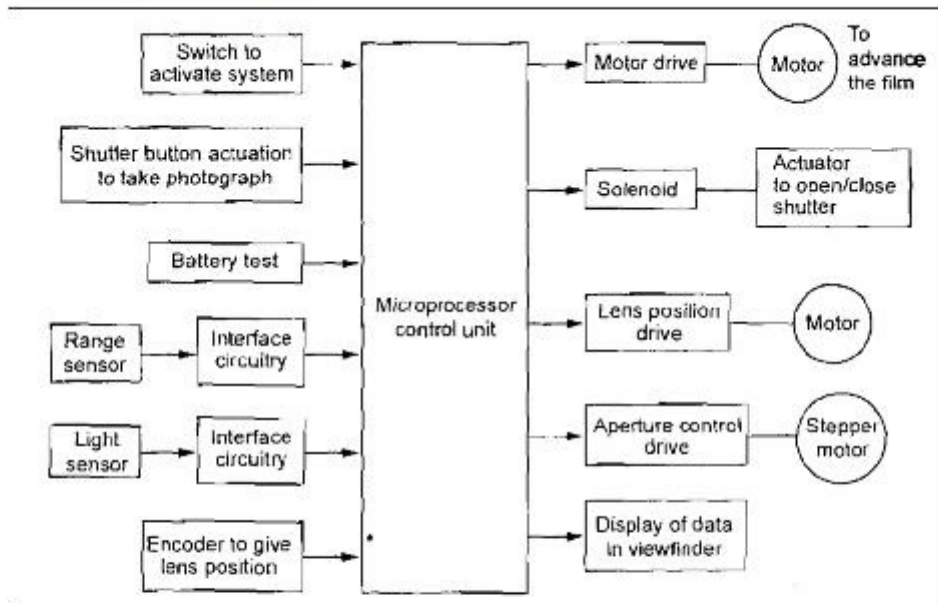

- The modern camera is likely to have automatic focusing and exposure. Figure 1.10 illustrates the basic aspects of a microprocessor-based system that can't be used to control the focusing and exposure.

- When the switch is operated to activate the system and the camera pointed at the object being photographed, the microprocessor takes the input from the range sensor and sends an output to the lens position drive to move the lens to achieve focusing. The lens position is fed back to the microprocessor so that the feedback signal can't be used to modify the lens position according to the inputs from the range sensor.
- The light sensor gives an input to the microprocessor which then gives an output to determine, if the photographer has selected the shutter controlled rather than aperture controlled mode, the time for which the shutter will be opened. When the photograph has been taken, the microprocessor gives an output to the motor drive to advance the film ready for the next photograph.
- The program for the microprocessor is a number of steps where the microprocessor is making simple decisions of the form: is there an input signal of a particular input line or not and if there is output a signal on a particular output line. The decisions are logic decisions with the input and output signals either being low or high to give on-off states. A few steps of the program for the automatic camera might be of the form: begin if battery check input OK then continue otherwise stop loop read input from range sensor calculate lens movement output signal to lens position drive input data from lens position encoder compare calculated output with actual output stop output when lens in correct position send in-focus signal to viewfinder display

ENGINE MANAGEMENT SYSTEM:

The engine management system of a car is responsible for managing the ignition and fuelling requirements of the engine.

- With a four-stroke internal combustion engine there are several cylinders, each of which has a piston connected to a common crankshaft and each of which carries out a four-stroke sequence of operations

- When the piston moves down a valve opens and the air —fuel mixture is drawn into the cylinder.
- When the piston moves up again the valve closes and the air —fuel mixture is compressed.
- When the piston is near the top of the cylinder the spark plug ignites the mixture with a resulting expansion of the hot gases. This expansion causes the piston to move back down again and so the cycle is repeated.
- The pistons of each cylinder are connected to a common crankshaft and their power strokes occur at different times so that there is continuous power for rotating the crankshaft.
- The power and speed of the engine are controlled by varying the ignition timing and the air —fuel mixture.
- With modern car engines this is done by a microprocessor. Figure 1.12 shows the basic elements of a microprocessor control system.

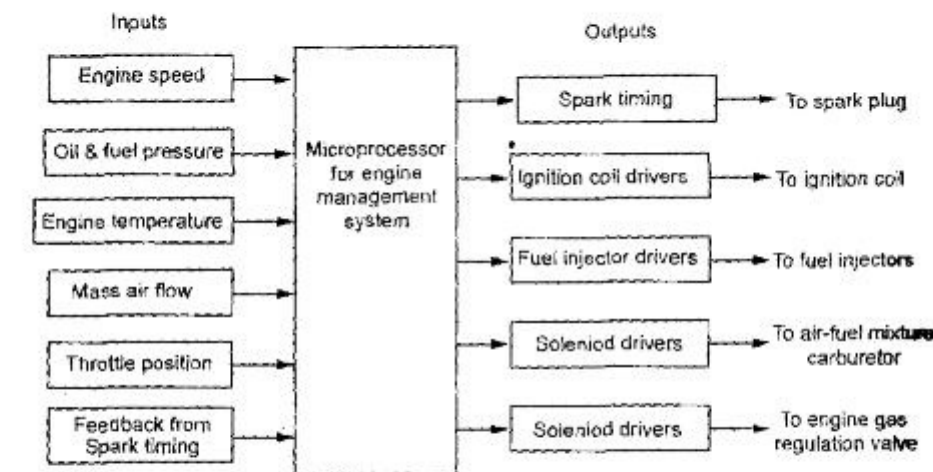

- For ignition timing, the crankshaft drives a distributor which makes electrical contact for each spark plug in turn and a timing wheel. This timing wheel generates pulses to indicate the crankshaft position.
- The microprocessor then adjusts the timing at which high voltage pulses are sent to the distributor so they occur at the right moments of time.

- To control the amount of air —fuel mixture entering a cylinder during the intake strokes, the microprocessor varies the time for which a solenoid is activated to open the intake on the basis of inputs received of the engine temperature and the throttle position.
- The amount of fuel to be injected into the air stream can be determined by an input from a sensor of the mass rate of air flow, or computed from other measurements, and the microprocessor then gives an output to control a fuel injection valve.

SENSORS

Transducers:

- It is an element which is subjected to physical change experience a related change.

Example: Tactile Sensors.

Sensors:

- It is an element which is not subjected to physical change experience a related change.

Example: LVDT

PERFORMANCE TERMINOLOGY:

Static Characteristics:

Range and Span:

- The range of a transducer defines the limits between which the input can vary.
- The difference between the limits (maximum value - minimum value) is known as span. For example a load cell is used to measure force. An input force can vary from 20 to 100 N. Then the range of load cell is 20 to 100 N. And the span of load cell is 80 N (i.e., 100-20)

Error:

- The algebraic difference between the indicated value and the true value of the measured parameter is termed as the error of the device.
- Error = Indicated value — true value
- For example, if the transducer gives a temperature reading of 30°C when the actual temperature is 29° C, then the error is + 1°C. If the actual temperature is 31° C, then the error is — 1°C.

Accuracy:

- Accuracy is defined as the ability of the instrument to respond to the true value of the measure variable under the reference conditions.
- For example, a thermocouple has an accuracy of $\pm 1^\circ \text{C}$. This means that reading given by the thermocouple can be expected to lie within + 1°C (or) — 1°C of the true value.
- Accuracy is also expressed as a percentage of the full range output (or) full scale deflection
- For example, a thermocouple can be specified as having an accuracy of $\pm 4\%$ of full range output. Hence if the range of the thermocouple is 0 to 200°C, then the reading given can be expected to be within + 8°C (or) — 8°C of the true reading.

Sensitivity:

The sensitivity is the relationship showing how much output we can get per unit input.

- sensitivity = Output / Input

Precision:

It is defined as the degree of exactness for which the instrument is intended to perform.

Hysteresis error:

When a device is used to measure any parameter plot the graph of output Vs value of measured quantity.

First for increasing values of the measured quantity and then for decreasing values of the measured quantity.

The two output readings obtained usually differ from each other.

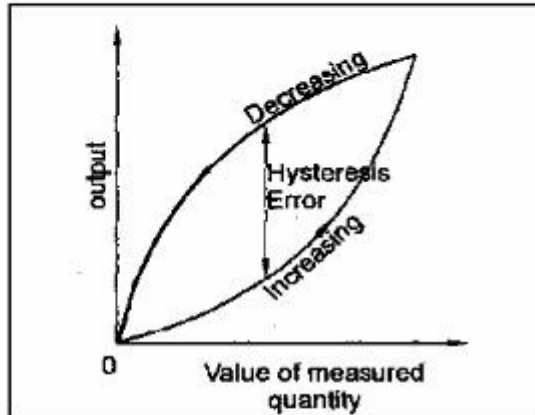

Repeatability:

The repeatability and reproducibility of a transducer are its ability to give the same output for repeated applications of the same input value.

Reliability:

The reliability of a system is defined as the possibility that it will perform its assigned functions for a specific period of time under given conditions.

Stability:

The stability of a transducer is its ability to give the same output when used to measure a constant input over a period of time.

Drift:

The term drift is the change in output that occurs over time.

Dead band:

There will be no output for certain range of input values. This is known as dead band. There will be no output until the input has reached a particular value.

Dead time:

It is the time required by a transducer to begin to respond to a change in input value.

Resolution:

Resolution is defined as the smallest increment in the measured value that can be detected.

The resolution is the smallest change in the input value which will produce an observable change in the input.

Backlash:

Backlash is defined as the maximum distance (or) angle through which any part of a mechanical system can be moved in one direction without causing any motion of the attached part.

Backlash is an undesirable phenomenon and is important in the precision design of gear trains.

SELECTION OF DISPLACEMENT, POSITION & PROXIMITY SENSOR:

- Size of the displacement (mm)
- Displacement type (Linear or angular)
- Resolution required
- Accuracy Required
- Material of the object
- Cost

DISPLACEMENT SENSORS

- Displacement sensors are contact type sensor

Types of Displacement sensors:

- Potentiometer
- Strain gauge
- Capacitive sensors
- Linear variable differential transformer

POTENTIOMETER

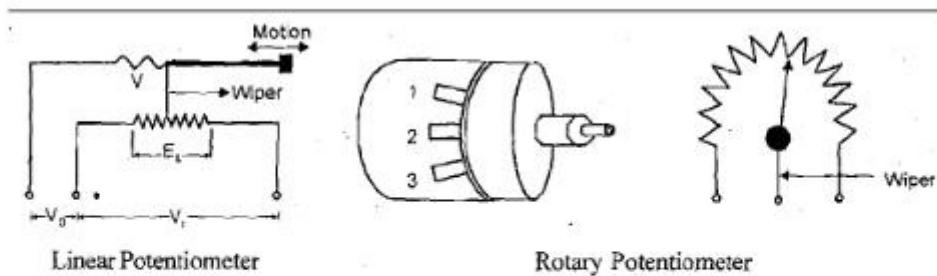

PRINCIPLE:

- It works on variable resistance transduction principle
- Linear or Rotary potentiometer is a variable resistance displacement transducer which uses the variable resistance transduction principle in which the displacement or rotation is converted into a potential difference due to the movement of sliding contact over a resistive element

CONSTRUCTION & WORKING:

- A resistor with three terminals.
- Two end terminal & one middle terminal (wiper)
- Two end terminal are connected to external input voltage
- One middle and one end terminal as output voltage
- The slider determines the magnitude of the potential difference developed

Characteristics:

Resistance element = Precision Drawn wire with a diameter of about 25 to 50 microns, and wad over a cylindrical or a flat mandrel of ceramic, glass or Anodized Aluminium. 2mm to 500 mm in case of linear pot. = For high resolution, wire is made by using ceramic (cermet) or conductive plastic film due to low noise levels. Wipers (Sliders) = Tempered phosphor bronze, beryllium copper or other precious alloys. Wire Material = Strong, ductile and protected from surface corrosion by enamelling or oxidation. Materials & e alloys of copper nickel, Nickel

chromium, and silver palladium. = Resistivity of wire ranges from $0.4 \mu\Omega\text{m}$ to $13 \mu\Omega\text{m}$

- Resistance range = 20Ω to $200\text{K}\Omega$ and for plastic 500Ω to $80\text{K}\Omega$
- Accuracy = Higher temperature coefficient of resistance than the wire and so temperature changes have a greater effect Accuracy.

STRAIN GAUGE:

Strain gauges are passive type resistance sensor whose electrical resistance change when it is stretched or compressed (mechanically strained) under the application of force. The electrical resistance is changed due to the change in length (increases) and cross sectional area (decreases) of the strain gauge. This change in resistance is then usually converted into voltage by connecting one, two or four similar gauges as an arm of a Wheatstone bridge (known as Strain Gauge Bridge) and applying excitation to the bridge. The bridge output voltage is then a measure of strain, sensed by each strain gauge.

Unbonded Type Strain Gauges:

- In unbonded type, fine wire filaments (resistance wires) are stretched around rigid and electrically insulated pins on two frames.
- One frame is fixed and the other is movable.
- The frames are held close with a spring loaded mechanism.
- Due to the relative motion between two frames, the resistance wires are strained.
- This strain is then can be detected through measurement of the change in electrical resistance since they are not cemented with the surfaces, they can be detached and reused.

Bonded Type Strain Gauges:

- Bonded **type** strain gauges consists of resistance elements arranged in the form of a grid of fine wire, which is cemented to a thin paper sheet or very thin Bakelite sheet, and covered with a protective sheet of paper or thin Bakelite.
- The paper sheet is then bonded to the surface to be strained. The gauges have a bonding material which acts an adhesive material during bonding process of a surface with the gauge element.

Classification of Bonded Type Strain Gauges:

- Fine wire gauges
- Metal foil gauges
- Semiconductor filament type

Fine Wire Gauges:

- Wire of 3 to 25 microns diameter is arranged in the form of grid consisting of parallel loops

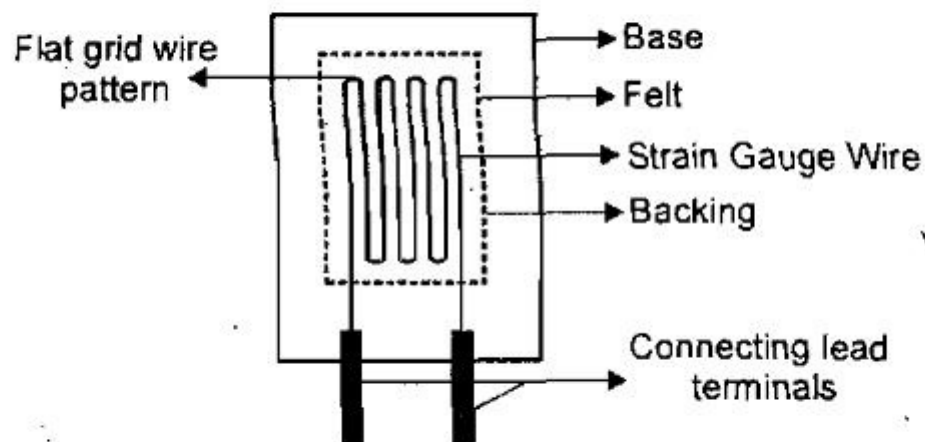

Metal Foil Gauges:

- A thin foil of metal, deposited as a grid pattern onto a plastic backing material using polyimide
- Foil pattern is terminated at both ends with large metallic pads
- Entire gauge size 5- 15mm
- Adhesive directly bonded to the gauge usually epoxy

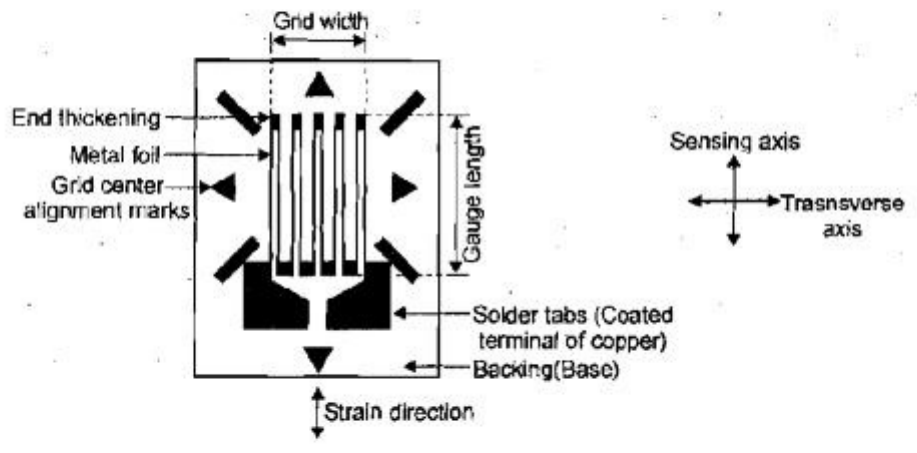

Semiconductor Filament Type:

- The gauges are produced in wafers from silicon or germanium crystals
- Special impurities such as boron is added
- It is mounted on an epoxy resin backing with copper on nickel leads
- Filament about 0.05mm thick 0.25mm wide and 1.25 to 12mm length

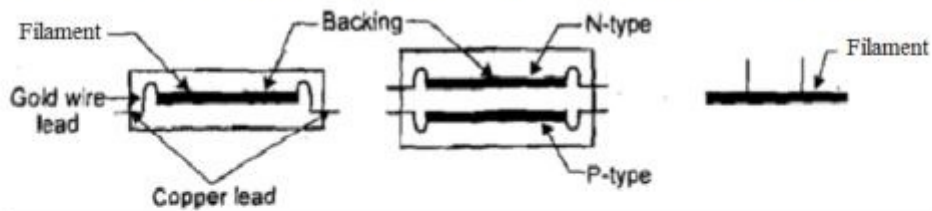

CAPACITIVE SENSORS:

- It is used for measuring, displacement, velocity, force etc..

Principle:

- It is passive type sensors in which equal and opposite charges are generated on the plates due to voltage applied across the plate which is separated by dielectric material.

Formula:

By Changing the Distance between Two Plates:

- The displacement is measured due to the change in capacitance

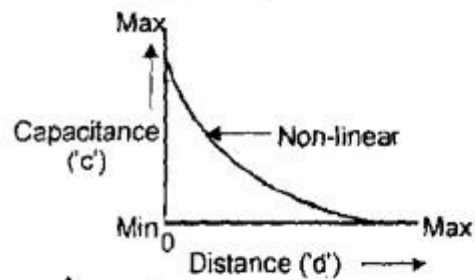
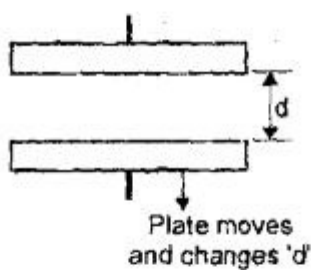

By Varying the Area of Overlap:

- The displacement causes the area of overlap to vary
- The capacitance is directly proportional to the area of the plates and varies linearly with changes in the displacement between the plates

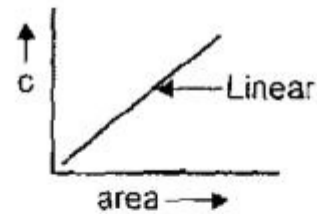
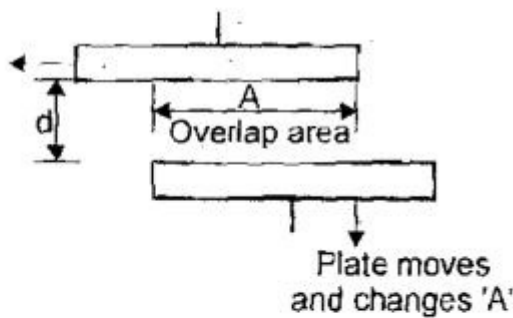

By Varying the Dielectric Constant:

- The change in capacitance can be measured due to change in dielectric constant as a result of displacement.
- When the dielectric material is moved due to the displacement, the material causes the dielectric constant to vary in the region where the two electrodes are separated that results in a change in capacitance.

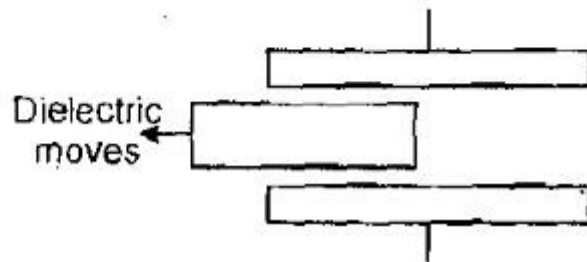

Push Pull Sensor:

- Push pull displacement sensor is used to overcome the non-linearity error.
- The sensor consists of three plates with the upper pair forming one capacitor and the lower pair forming another capacitor.
- The displacement moves central plate between the two other plates.
- If the central plate moves downwards.
- The plate separation of the upper capacitor increases and the separation of the lower one decreases.

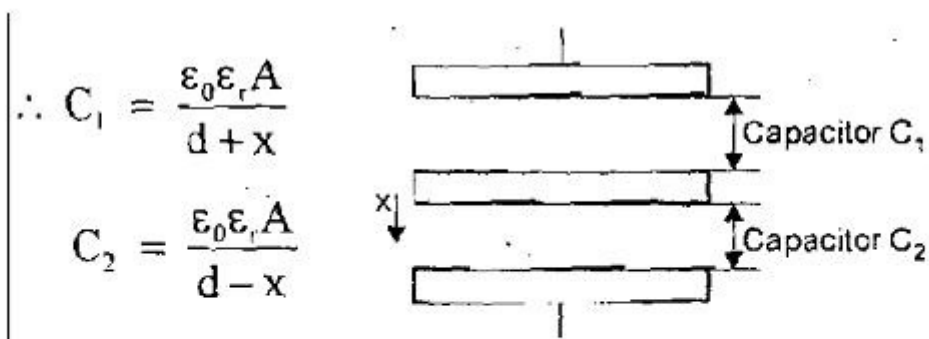

LINEAR VARIABLE DIFFERENTIAL TRANSFORMER:

- It consists of three symmetrically spaced coils.

- The centre coil is primary coil and other two are secondary coil
- Secondary coils are connected in series opposition and equally positioned with respect to primary coil
- The output voltage is proportional to the displacement of the core from null position

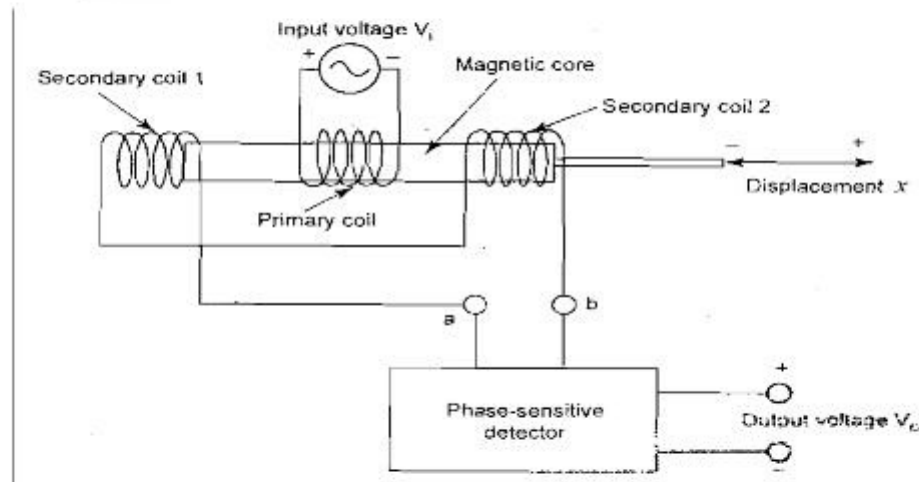

PROXIMITY SENSORS

- Proximity sensors are non – contact type sensor.

Types of Proximity Sensor:

- Eddy current proximity sensor
- Inductive proximity sensor
- Pneumatic proximity sensor
- Proximity switches

EDDY CURRENT PROXIMITY SENSOR:

PRINCIPLE:

When a coil is supplied with alternating current, an alternating magnetic field is produced which induces an EMF on it. If there is a metal near to this alternating magnetic field, an EMF is induced in it. The EMF causes current to

flow. This current flow is eddy current.

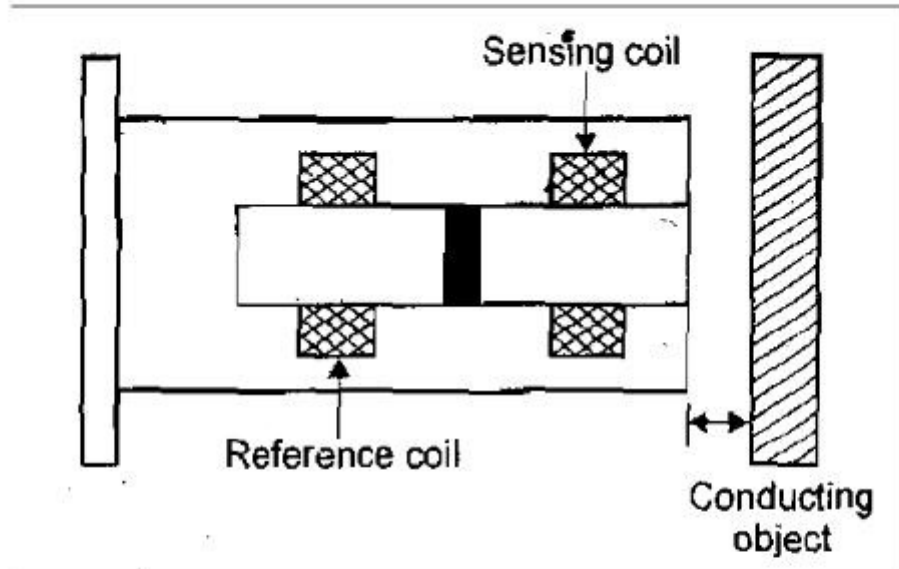

CONSTRUCTION & WORKING:

- It has two identical coils.
- One reference coil & another sensing coil which senses the magnetic current in the object.
- Eddy current start to flow due to AC(conducting object) close to sensor
- Eddy current produce a magnetic field to oppose the magnetic field generated by sensing coil.
- Due to this opposition reduction flux is created. To detect 0.001mm

INDUCTIVE PROXIMITY SENSORS:

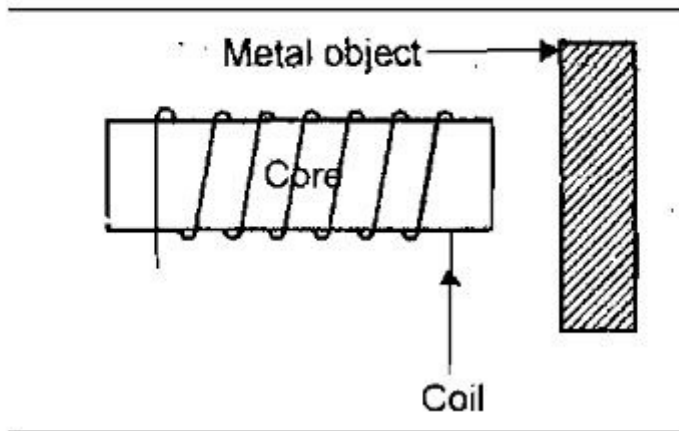

- It consists of coil wound round a core.
- Metal is close to coil Inductance changes occurs.
- It is suitable for ferrous metals

PNEUMATIC PROXIMITY SWITCHES:

- It is suitable for sensing non conducting materials
- Air is allowed to escape from the front side of the sensor.
- When there is no object air escapes freely.
- When there is an object, the escaping air is blocked and return backed to system.
- It is used to measure the range 3mm to 12mm

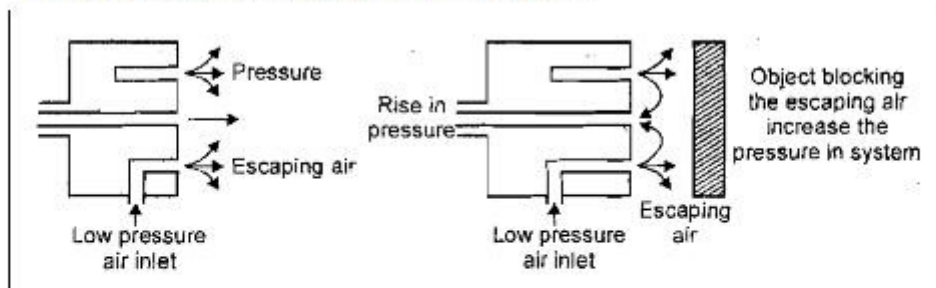

PROXIMITY SWITCHES:

- It is used in robotics for sensing elements
- It is also used in NC machines, material handling systems and assembly lines.
- Micro switch
- Reed switch
- Photo sensitive switch
- Mechanical switch

Micro Switch:

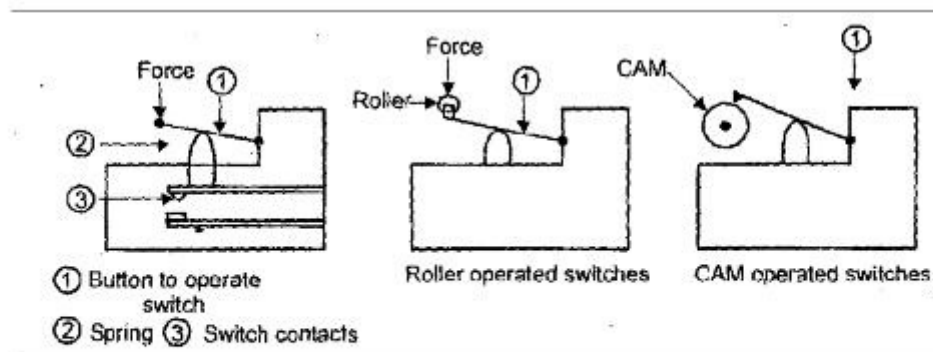

- It is limit switch operated by levers, rollers & cams
- It is switch which requires physical contact and small force to close the contacts.
- Example a belt conveyer.

Reed Switch:

- It is a non – contact proximity switch that consists of two magnetic switch contacts enclosed in a glass tube fined with an inert gas.
- When magnet is closed switch is operated.

- Used for high speed applications.

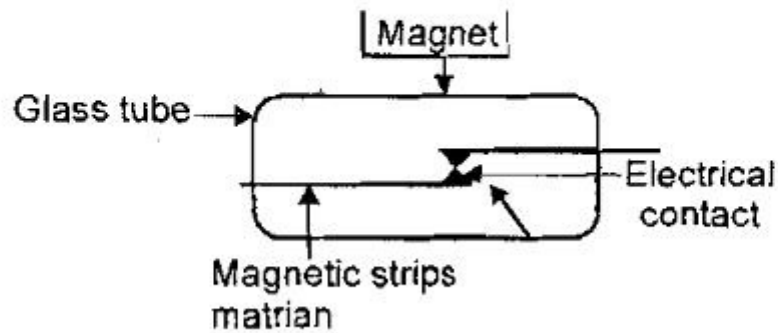
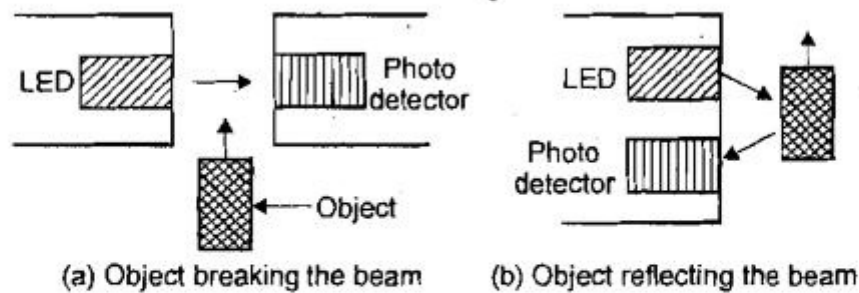

Photo Sensitive Devices:



- It is used to sense opaque object.
- Photo detector receives a beam of light produced by the LED.
- Object is passed the beam gets broken or reflected when is detected.

OPTICAL ENCODERS

- It is used to measure position, velocity, acceleration and direction of movement of rotors.

INCREMENTAL ENCODERS

PRINCIPLE:

- When a beam of light passes through slots in a disc, it is sensed by the light sensor opposite to the light source

- When the disk is rotated, a pulsed output is produced by sensor with number of pulses being proportional to the position of the disc and number of pulses per second determines the velocity of the disk

CONSTRUCTION & WORKING:

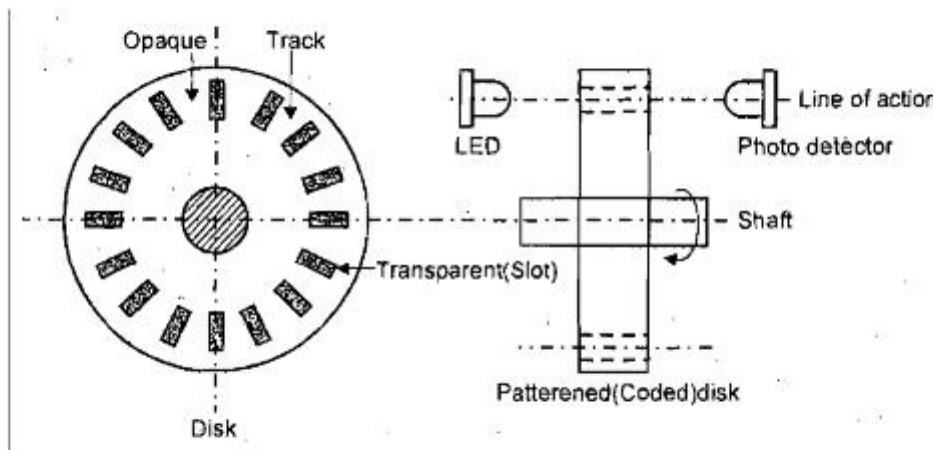

- It consists three components light source, coded disk and photo detector
- The disk is made up of plastic or glass.
- The disk consists of opaque and transparent segment alternatively.
- The wheel is between light and photo detector.
- The photo detector receives the light signal alternatively which is converted into electrical signal.

ABSOLUTE ENCODERS

PRINCIPLE:

- The principle of operation is that they provide a unique output corresponds to each rotational position of the shaft.
- The output is in the form of binary numbers representing the angular position.

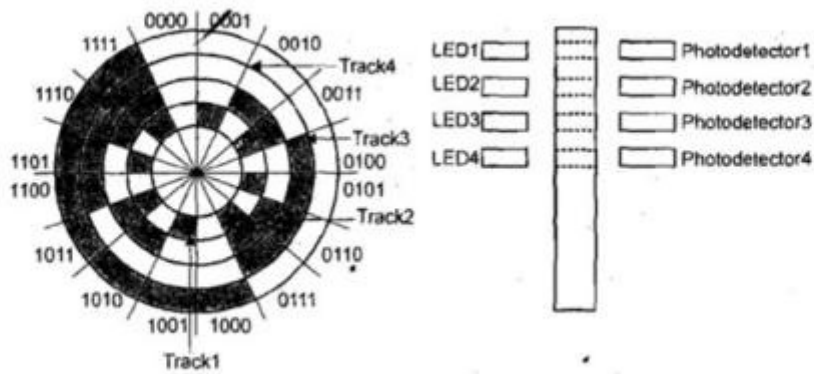

	Normal	Binary	Gray	Code
0	0000		0000	
1	0001		0001	
2	0010		0011	
3	0011		0010	
4	0100		0110	
5	0101		0111	
6	0110		0101	
7	0111		0100	
8	1000		1100	
9	1001		1101	
10	1010		1111	

CONSTRUCTION & WORKING:

- The disc has four concentric slots and four photo detectors to detect the light pulse.
- The slots are arranged in such way that they give a binary number.
- It consist opaque and transparent segments. This pattern is called as track.
- The encoders have 8 to 14 slots.
- The number of the track determines the resolution of the encoder.
- The number of bits in binary number will be equal to the number of tracks.

HALL EFFECT SENSORS:

Principle:

- When a current carrying semiconductor plate is placed in a transverse magnetic field, it experiences a force (Lorentz force). Due to this action a beam of charged particles are forced to get displaced from its straight path. This is known as Hall Effect.
- A current flowing in a semiconductor plate is like a beam of moving charged particles and thus can be deflected by a magnetic field. The side towards which the moving electron deflected becomes negatively charged and the other side of the plate becomes positively charged or the electrons moving away from it.
- This charge separation produces an electrical voltage which continues until the Lorentz force on the charged particles from the electric field balances the forces produced by the magnetic field. The result is a transverse potential difference known as Hall voltage.

Construction

&

Working:

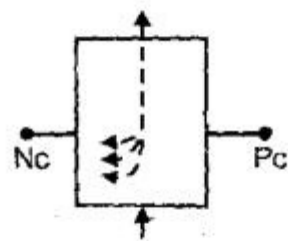
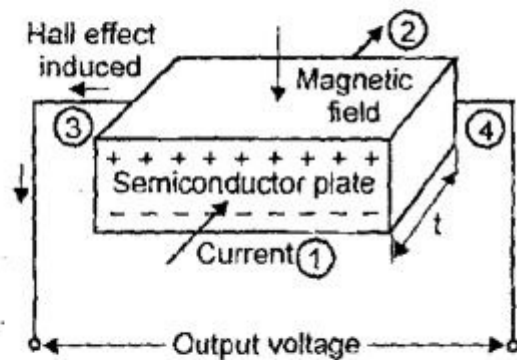

NC-Negatively charged
PC-Positively charged
I-Current

- Current is passed through leads 1 and 2 of the semiconductor plate and the output leads are connected to the element faces 3 and 4.

- These output faces are at same potential when there is no transverse magnetic field passing through the element and voltage **known** as Hall voltage appears when a transverse magnetic field is passing through the element.
- This voltage is proportional to the current and the magnetic field.
- The direction of deflection depends on the direction of applied current and the direction of magnetic field

FLUID SENSORS

FLUID PRESSURE SENSORS:

Diaphragm Type:

- In the diaphragm type sensor, when there is a difference in pressure between the two sides then the centre of the diaphragm becomes displaced.
- Corrugations in the diaphragm result in a greater sensitivity.
- This movement can be monitored by some form of displacement sensor, e.g: a strain gauge.
- A specially designed strain gauge is often used, consisting of four strain gauges with two measuring the strain in a circumferential direction while two measure strains in a radial direction
- The four strain gauges are then connected to form the arm of a Wheatstone bridge.
- While strain gauges can be stuck on a diaphragm, an alternative is to create a silicon diaphragm with the strain gauges as specially doped areas of the diaphragm.

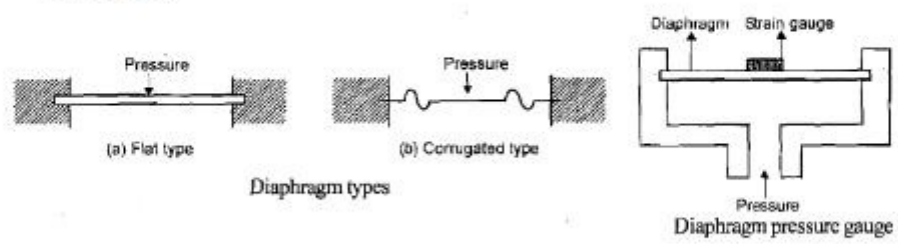

Capsule and Bellows Types:

- Capsules are two corrugated diaphragms combined to give greater accuracy
- Capsules and bellows are made up of stainless steel, phosphor bronze, and nickel with rubber and nylon
- Pressure range 10^3 to 10^8 Pa

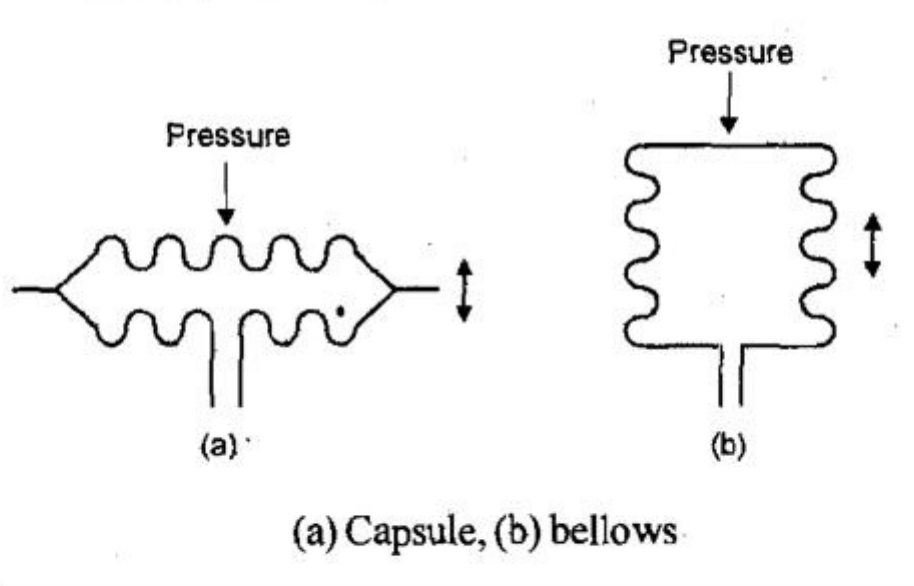

Tube Pressure Sensor:

- A different form of deformation is obtained using a tube with an elliptical cross section
- Increase in pressure in tube causes it tend to circular cross – section
- C – Shaped tube is generally known as a Bourdon tube.
- C opens when pressure in the tube increases
- A helical form gives more sensitivity
- Tubes are made up of stainless steel, phosphor bronze, and nickel with rubber and nylon
- Pressure range 10^3 to 10^8 Pa

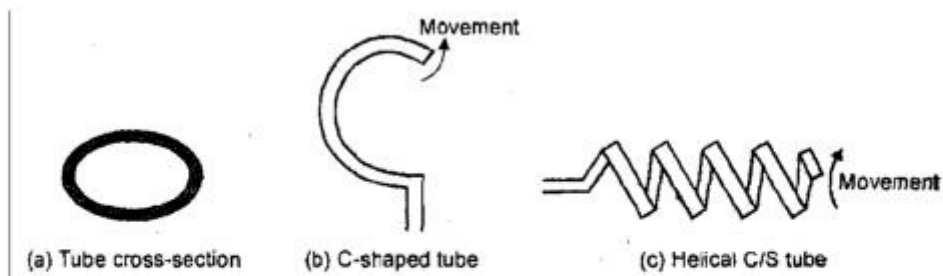

Piezoelectric Sensors:

- Piezoelectric materials when stretched or compressed generate electric charges with one face of the material becoming positively charged and the opposite face negatively charged.
- As a result a voltage is produced. The net charge q on a surface is proportional to the amount x by which the charges have been displaced, and since the displacement is proportional to the applied force F .
- $q = kx = SF$
- Where k is a constant and S a constant termed the charge sensitivity

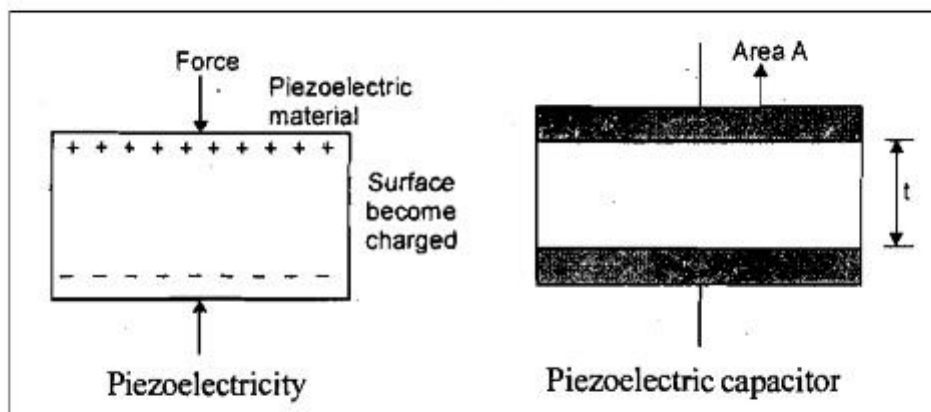

Tactile Sensor:

- It is used on fingertips of robot hands and for touch display screen
- It uses piezoelectric polyvinylidene fluoride (PVDF) film
- Two layers are separated by sift film

- The lower PVDF film has an alternating voltage applied to it results in mechanical oscillations
- Intermediate film transmits the vibration to upper film

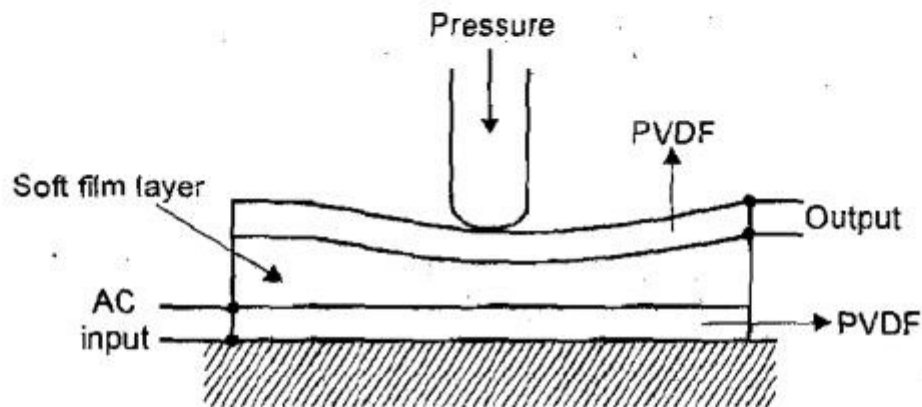

LIQUID FLOW SENSORS:

Turbine Flow Meter:

- The turbine flow meter consists of a multi-bladed rotor which is supported in the pipe along with the flow occurs.
- The rotor rotation depends upon the fluid flow and the angular velocity is proportional to the flow rate.
- The rotor rotation determines the magnetic pick-up, which is connected to the coil.
- The revolution of the rotor is determined by counting the number of pulses produced in the magnetic pick up. The accuracy of this instrument is $\pm 3\%$.

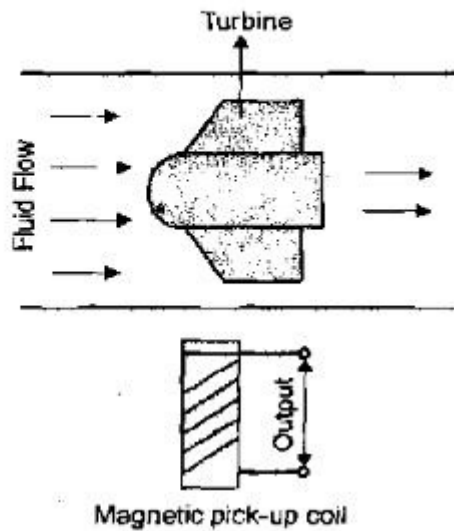

Orifice Plate:

- It is a simple disc with a central hole and it is placed in the tube through which the fluid flows.
- The pressure difference measured between a point equal to the diameter of the tube upstream and half the diameter of downstream.
- The accuracy of this instrument is $\pm 1.5\%$.

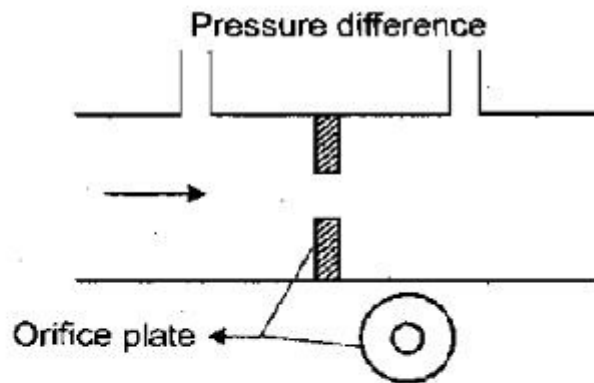

LIQUID LEVEL MEASUREMENT:

Differential Pressure Sensor:

- In this the differential pressure cell determines the pressure difference between base of the liquid and atmospheric pressure.
- The differential pressure sensor can be used in either form of open or closed vessel system.

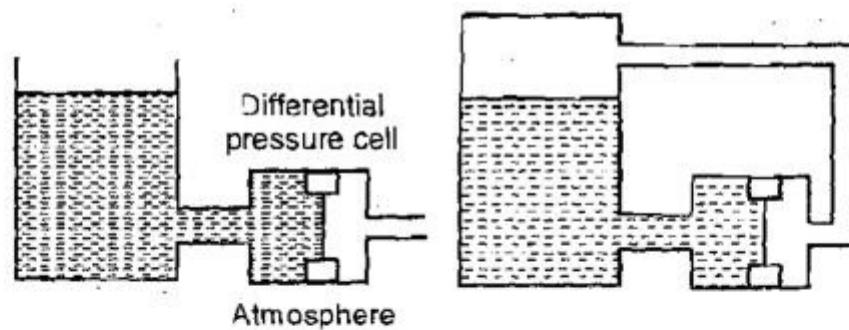

(a) Open Vessel type

(b) Closed Vessel type

Float System:

- In this method the level of liquid is measured by movement of a float.
- The movement of float rotates the arm and slider will move across a potentiometer.
- The output result is related to the height of the liquid.

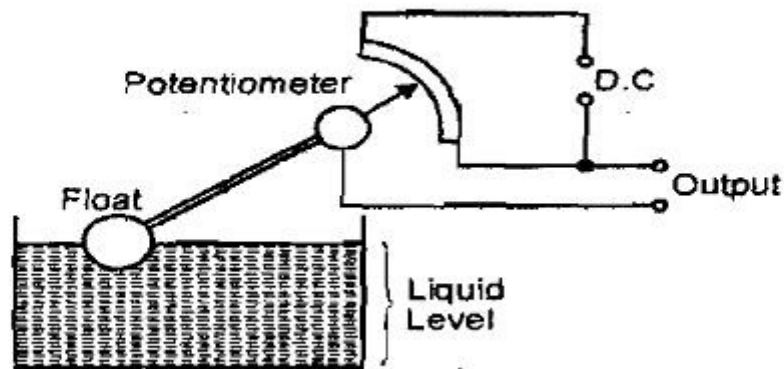

TEMPERATURE SENSORS:

Bimetallic Strips:

- A Bimetallic thermostat consists of two different metal strips bounded together and they cannot move relative to each other.
- These metals have different coefficients of expansion and when the temperature changes the composite strips bends into a curved strip, with the higher coefficient metal on the outside of the curve.
- The basic principle in this is all metals try to change their physical dimensions at different rates when subjected to same change in temperature.
- This deformation may be used as a temperature- controlled switch, as in the simple thermostat.

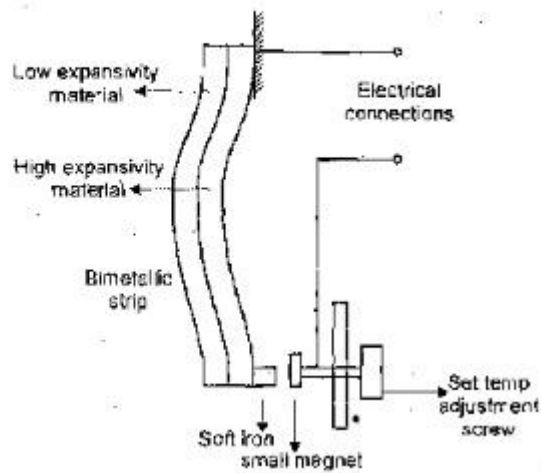

Resistance Temperature Detectors (RTDs):

- The materials used for RTDs are Nickel, Iron, Platinum, Copper, Lead, Tungsten, Mercury, Silver, etc.
- The resistance of most metals increases over a limited temperature range and the relationship between Resistance and Temperature is shown below.

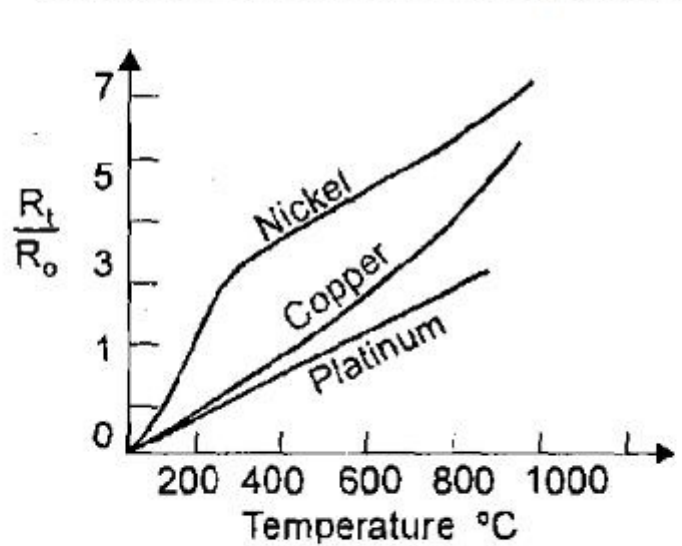

- The Resistance temperature detectors are simple and resistive elements in the form of coils of wire

- The equation which is used to find the linear relationship in RTD is

Constructional Details of RTDs:

- The platinum, nickel and copper in the form wire are the most commonly used materials in the RTDs.
- Thin film platinum elements are often made by depositing the metal on a suitable substrate wire-wound elements involving a platinum wire held by a high temperature glass adhesive inside a ceramic tube.

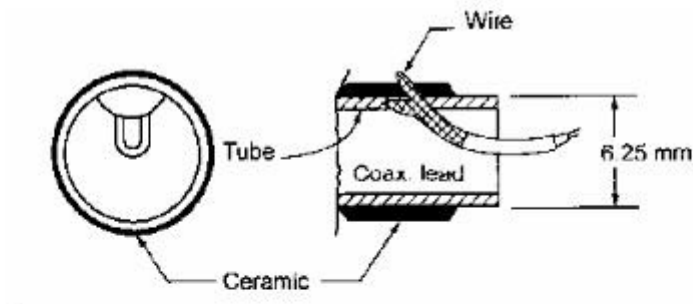

Thermistors:

- Thermistor is a semiconductor device that has a negative temperature coefficient of resistance in contrast to positive coefficient displayed by most metals.
- Thermistors are small pieces of material made from mixtures of metal oxides, such as Iron, cobalt, chromium, Nickel, and Manganese.
- The shape of the materials is in terms of discs, beads and rods.
- The thermistor is an extremely sensitive device because its resistance changes rapidly with temperature.
- The resistance of conventional metal-oxide thermistors decreases in a very non-linear manner with an increase in temperature.

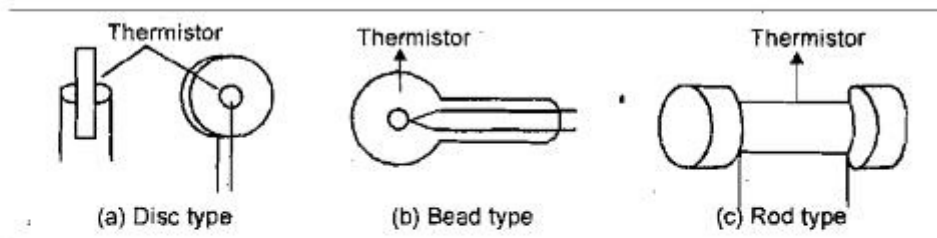

- The change in resistance per degree change in temperature is considerably larger than that which occurs with metals.
 - The resistance-temperature relationship for a thermistor can be described by an equation of the form
 - $R_t = K e^{\beta/t}$
 - Where R_t , is the resistance at temperature t , with K and β being constant.
- Thermistors have many advantages when compared with other temperature sensors.

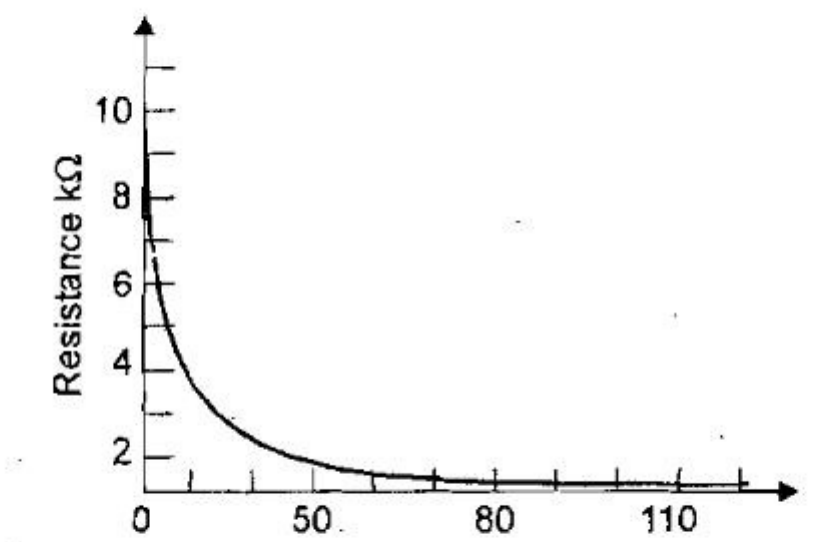

- The simple series circuit for measurement of temperature using a thermistor and the variation of resistance with temperature for a typical thermistor.

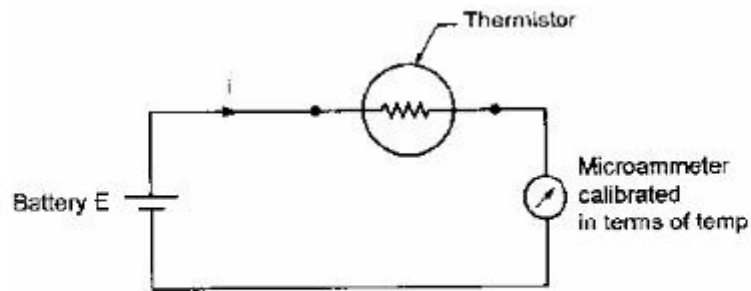

- The thermistor is an extremely sensitive device because its resistance changes rapidly with temperature.

Thermocouples:

- Thermocouples are based on the See back Effect.
- The thermocouple temperature measurement is based on a creation of an electromotive force (emf).

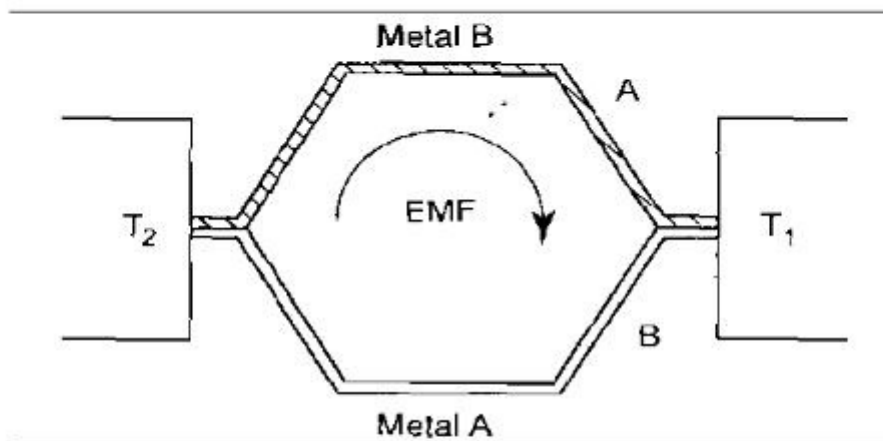

- "When two dissimilar metals are joined together an e.m.f will exist between the two points A and B, which is primarily a function of the junction temperature. The above said to be principle is See back effect..
- The thermocouple consist of one hot junction and one cold junction
- Hot junction is inserted where temperature is measured