

UNIT - V

MECHANICAL PROPERTIES AND DEFORMATION MECHANISM

5.1 MECHANICAL PROPERTIES:

1. ELASTICITY:

It is the property of a material by virtue of which it is able to retain its original shape and size after the removal of the load. E.g. Steel and rubber.

2. PLASTICITY:

It is the property of a material by virtue of which a permanent deformation (without fracture) takes place, whenever it is subjected to the action of external forces is subjected to the action of external forces. E.g. Clay and lead.

3. DUCTILITY: (Differentiate between ductility and malleability.)

It is the property of material by virtue of which it can be drawn into wires before rupture takes place. E.g. Gold, silver, iron, copper, aluminium and platinum

4. MALLEABILITY:

It is the property of a material by virtue of which it can withstand deformation under compression without rupture. E.g. Gold, lead

5. BRITTLENESS:

It is the property of a material by virtue of which it will fracture without any appreciable deformation. E.g.: Cast iron, glass

6. HARDNESS:

It is the proper of a material by virtue of which it is able to resist abrasion, indentation, machining and scratching. E.g. Diamond, quartz, glass

7. TOUGHNESS:

It is the property of a material by virtue of which it can absorb maximum energy before fracture takes place. E.g. Mild steel, brass, iron

8. STIFFNESS:

It is the property of a material by virtue of which it resists deformation.

9. RESILIENCE:

It is the property of a material by virtue of which it stores energy and resists shocks or impacts.

10. CREEP:

It is the property of a material by virtue of which it deforms continuously under a steady load.

11. ENDURANCE:

It is the property of a material by virtue of which it can with stand varying stresses.

12. STRENGTH:

It is the property of a material by virtue of which it can with stand or support an external force or load without rupture.

13. IMPACT STRENGTH:

It is the property of a material by virtue of which it can resist or absorb shock energy before it fractures.

14. FATIGUE:

It is the property of a material by virtue of which it deforms under the fluctuating or repeated loads.

FACTORS AFFECTING MECHANICAL PROPERTIES:

1. Grain size
2. Heat treatment
3. Atmospheric exposure
4. Low and high temperatures

5.2 TECHNICAL PROPERTIES:

1. MACHINABILITY:

It is the property of a material, which indicates the ease with which it can be cut or removed in various machining operations such as turning, drilling, boring, shaping.

2. CASTABILITY:

It is the property of a material, which indicates the ease with which it can be cast into different shapes and sizes.

3. WELDABILITY:

It is the property of a material, which indicates the ease with which two similar or dissimilar metals are welded.

4. FORMABILITY (OR) WORKABILITY:

It is the property of a material, which indicates the with which it can be formed into different shapes and sizes.

5.3 MECHANISMS OF PLASTIC DEFORMATION:

DEFORMATION:

The change that is produced in the shape of a metal piece due to the impact of forces acting on it is known as Deformation.

Types of deformation:

1. Elastic Deformation:

- When a material is stressed below its plastic limit, the resulting deformation or strain is temporary.
- Removal of stress results in a gradual return of the object to its original position. This is elastic deformation.

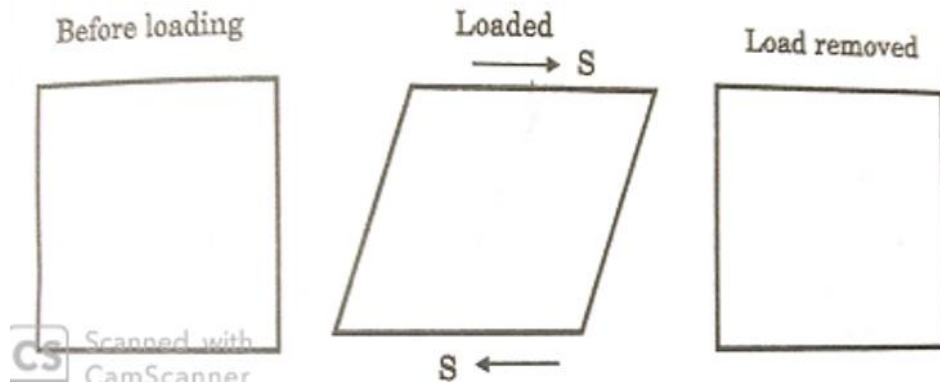

2. Plastic Deformation:

- When a material is stressed above its elastic limit, plastic or permanent deformation takes place and it will not return to its original shape.
- All metal working processes such as forging, rolling, spinning, drawing and extruding involve plastic deformation of metals.
- Various machining operations such as turning, milling, shaping and punching also involve plastic deformation.
- Plastic deformation is also carried out in order to improve some mechanical properties of metal and alloys.

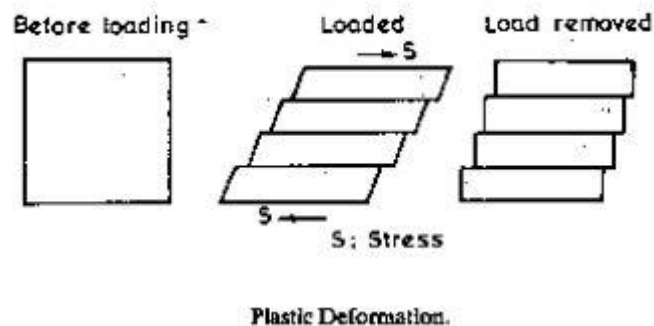

Plastic deformation is a function of

1. Applied stress
2. Temperature
3. Strain rate

Elastic & Plastic Deformation

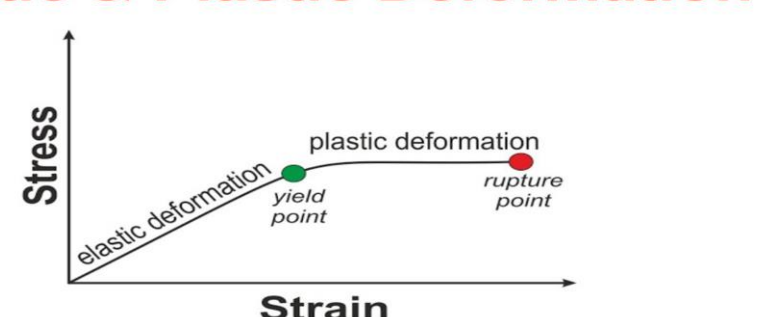

5.4 Mechanisms of plastic deformation: (Explain the mechanism of plastic deformation of metals by slip and twinning?)

1. Slip
2. Twinning

1. Slip

When one part of the crystal moves over another part it is called slip.

Mechanism of Slip:

- Deforming shear force is applied to a perfect crystal.
- Slip occurs along the slip plane
- Permanent deformation occurs even after the deforming force is removed.

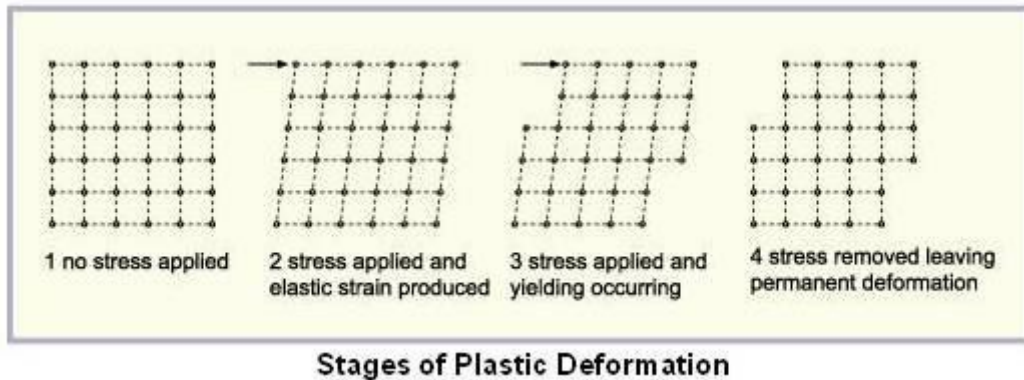

Slip plane: The particular crystallographic plane where slip occurs.

Slip direction: The direction along which slip occurs.

Slip system: The combination of slip plane & slip direction.

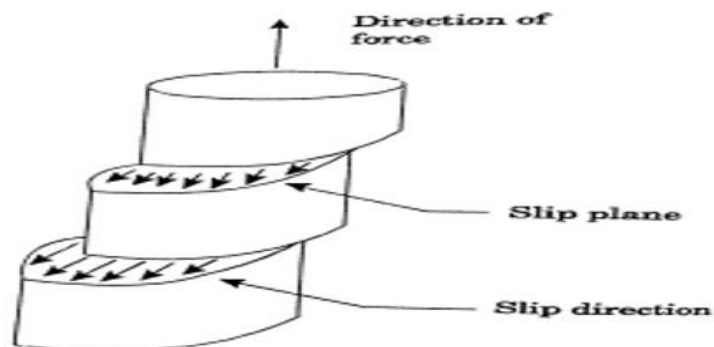

2. Twinning

- In the twinning mechanism, the atomic arrangement of one part looks like an exact mirror image of another part.
- The boundary of the plane which acts like a mirror is known as a twinning plane or a composition plane.
- Twinning which is created by the deformation process is called mechanical twinning.
- Twinning which is created by the heat treatment process is called annealing twinning.

Mechanical twinning occurs in metals that have BCC and HCP crystal structures at low temperatures and at high rates of loading. Annealing twinning is more common in FCC metals.

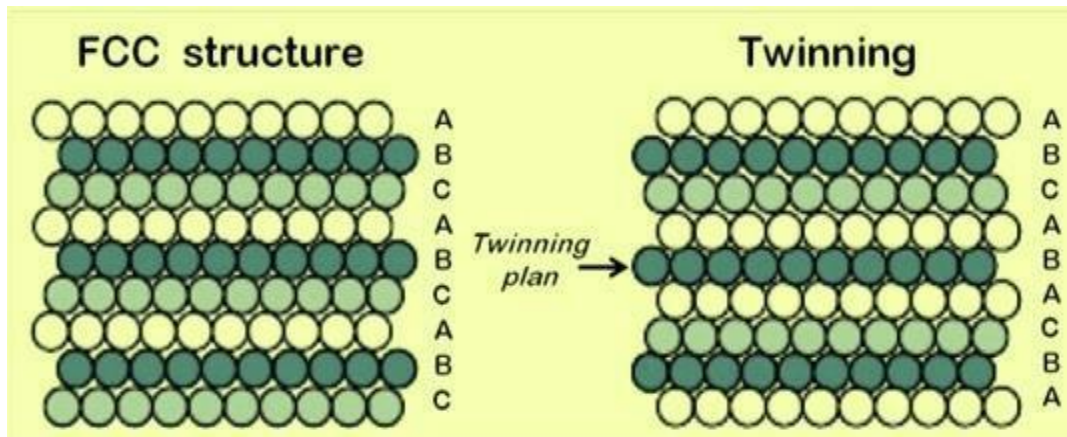

5.5 DIFFERENCES BETWEEN SLIP AND TWINNING:

(Write the difference between Slip and Twinning.)

Slip	Twinning
1. It appears as thin lines	It appears as broad lines
2. It occurs at low rates of loading	It occurs at high rates of loading
3. All atoms in one block move the same distance	Atoms in each successive plane within a block move different distance
4. There is a little change in lattice orientation	There is a great change in lattice orientation
5. It occurs along a single plane called the “slip plane”	It occurs between two planes called the “twin plane”

5.5 TYPES OF FRACTURE: (What are the different types of fractures in metallic materials? Formulate the important features of these fractured surfaces. What is the use of this study?)

(Define fracture.)

Fracture is the separation of a body into two or more parts under stress. The applied stress may be tensile, compressive, shear or torsional.

Fracture of a material may occur in the following ways:

- Slow application of external loads (tension).
- Rapid application of external loads (Impact).
- Repeated cyclic loading (Fatigue).
- Time and temperature dependent failure under a constant load (creep).

Fracture are classified into two types:

1. Brittle Fracture
2. Ductile Fracture

1. Brittle Fracture: (What is brittle fracture?)

- This process involves two steps 1. Crack formation 2. Crack propagation.
- No deformation occurs but crack propagation takes place rapidly.
- In single crystals, brittle fracture occurs by fracture along a particular crystallographic planes.
- Brittle Fracture may occur in boilers, ships, airplanes and pipe lines.

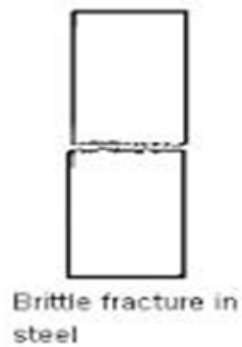

Mechanism of brittle fracture (Griffith theory)

Postulates:

- The crack propagates when the decrease in elastic strain energy is equal to the energy required to create the crack.
- In a brittle material always there are micro cracks at which the critical stress acts.
- When the applied stress is below the critical value, micro crack will not grow.
- When the applied stress is equal to the critical value, micro crack will grow in its size.
- The expression for maximum stress is, $\sigma_{max} = 2\sigma\sqrt{(c/r)}$

2. Ductile Fracture: (Define ductile fracture.)

- Ductile fracture means fracture of material with large plastic deformation before fracture.
- Fracture of soft steel and other soft metals, rubber, and plastics is ductile fracture.
- Ductile fracture is caused by the progressive degradation of material stiffness when plastic deformation reaches a certain limit.

Steps in which ductile fracture occurs:

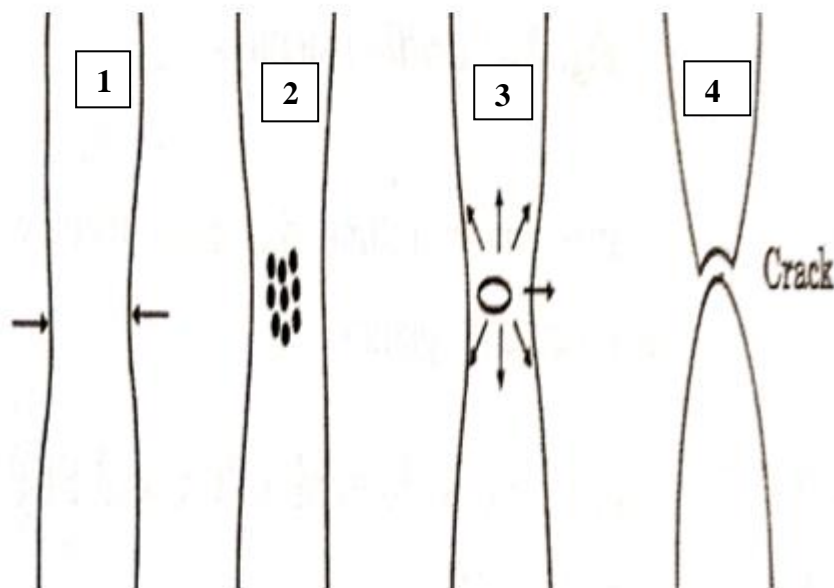

Steps in which ductile fracture occurs

1. **Neck Formation** - Under tensile load, the neck formation first takes place.
2. **Formation of crack** - After necking, small cavities are formed.
3. **Propagation of crack** - Next, as deformation continuous, the crack continuous to grow in a direction parallel to its major axis.
4. **Crack occurs** - Finally, fracture occurs at the neck at an angle 45° to the tensile direction.
5. This type of fracture is termed as cup and cone fracture because one of the mating surfaces is in the form of a cup, the other is like a cone.

COMPARISON BETWEEN BRITTLE AND DUCTILE FRACTURE:

(Differentiate between Brittle fracture and ductile fracture)

Brittle Fracture	Ductile Fracture
1. It occurs with negligible plastic deformation.	It occurs with large plastic deformation.
2. Crack propagation rate is rapid	Crack propagation rate is slow.
3. It follows the grain boundaries	It occurs through the grains.
4. There is failure due to direct axial stress.	There is failure due to shear stress.
5. It is characterized by the separations of normal to tensile stress.	It is characterized by the formation of cup and cone.
6. The tendency of brittle fracture is increased with decreasing temperature and increasing strain rate.	The tendency of ductile fracture is increased with dislocations and other metal defects
7. Materials that undergo brittle fracture are glass, ceramics etc.	Materials that undergo ductile fracture are mild steel, brass etc.

5.7 TESTING OF MATERIALS: (Explain i) Compression test ii) Shear test iii) Tension test)

1. Tension Test
2. Compression Test
3. Shear Load Test

1. Tension Test:

- One of the most useful tests applied to metallic materials is the tensile test.
- The test is conducted at **room temperature** by applying a **gradual increasing tensile load** to a standard test specimen.

- To conduct the test, the specimen is gripped between fixed and movable headers of **universal testing machine**.
- In the test, load is increased gradually and corresponding stress – strain diagram is obtained with the aid of instrument, attached to the machine.

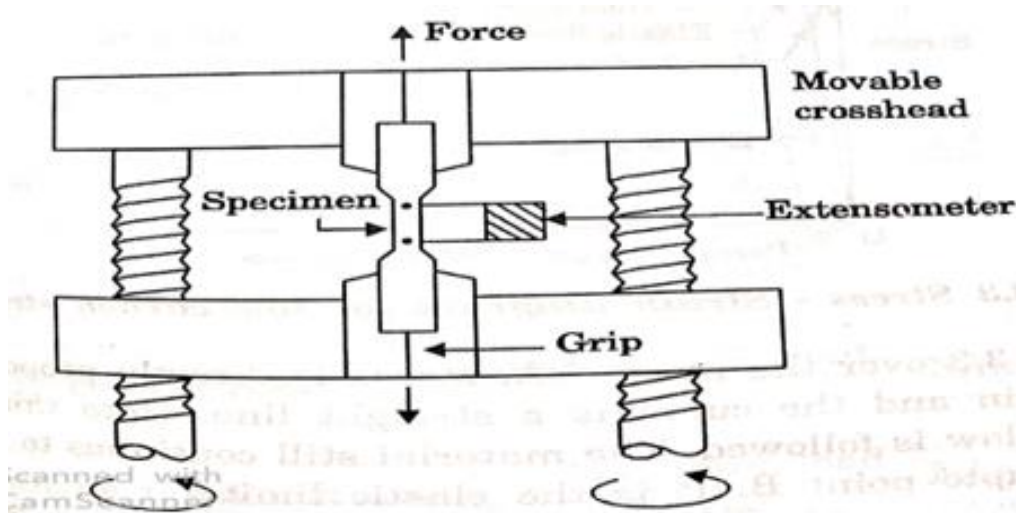

Stress –Strain diagram:

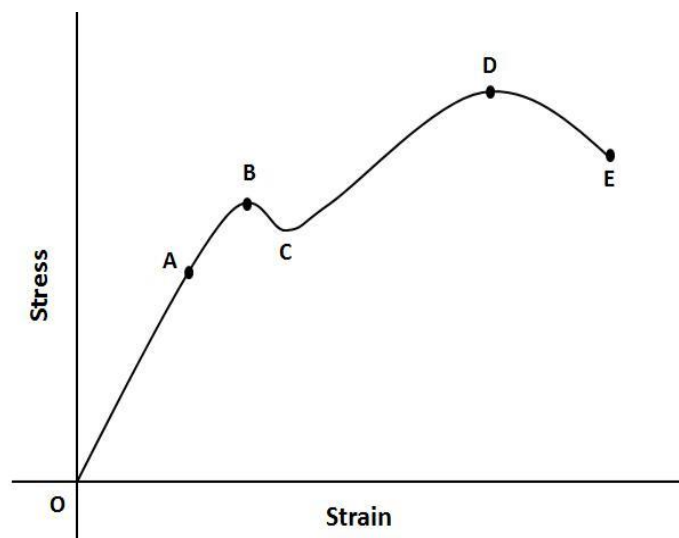

Stress-strain diagram for Tension test

- A - Proportional limit
 - B - Elastic limit
 - C - yield point
 - D - tensile strength
 - E - Fracture
- **Proportional limit (A):**
It is the maximum stress at which strain is directly proportional to the stress.
 - **Elastic limit (B):**
It is the maximum stress at which the specimen is deformed without fracture, under tensile load.
 - **Yield point (C):**
It is the minimum stress at which the specimen is deformed without an increase in load.
 - **Tensile strength (D):**

It is the maximum stress that a material can with stand, without fracture, under tensile load.

2. Compression Test:

- A compression test is a **method for determining the behaviour of materials under a compressive load.**
- Compression tests are conducted by loading the test specimen between two plates, and then applying a force to the specimen by moving the crossheads together.
- To determine compressive properties a specimen is usually chosen in which the length is three times the diameter.
- During the test, the specimen is compressed, and deformation versus the applied load is recorded. The compression test is used to determine elastic limit, proportional limit, yield point, yield strength, and compressive strength.

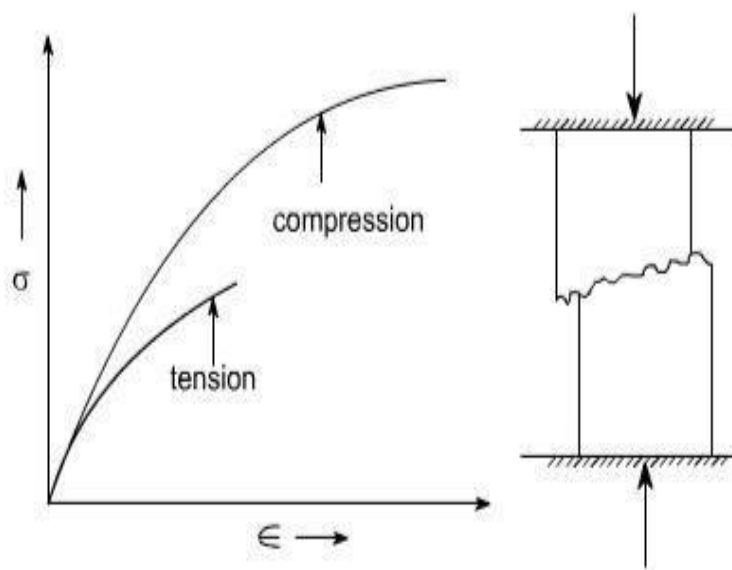
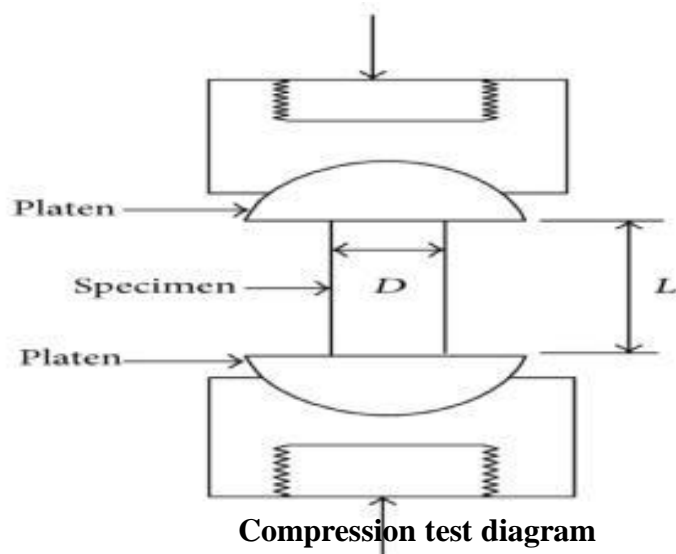

Stress strain curve for compression test

3. Shear load test:

- Shear refers to a sliding failure that occurs along a flat plane of a sample.
- During shear testing, force is applied to a material in a parallel direction, rather than holding it in tension.

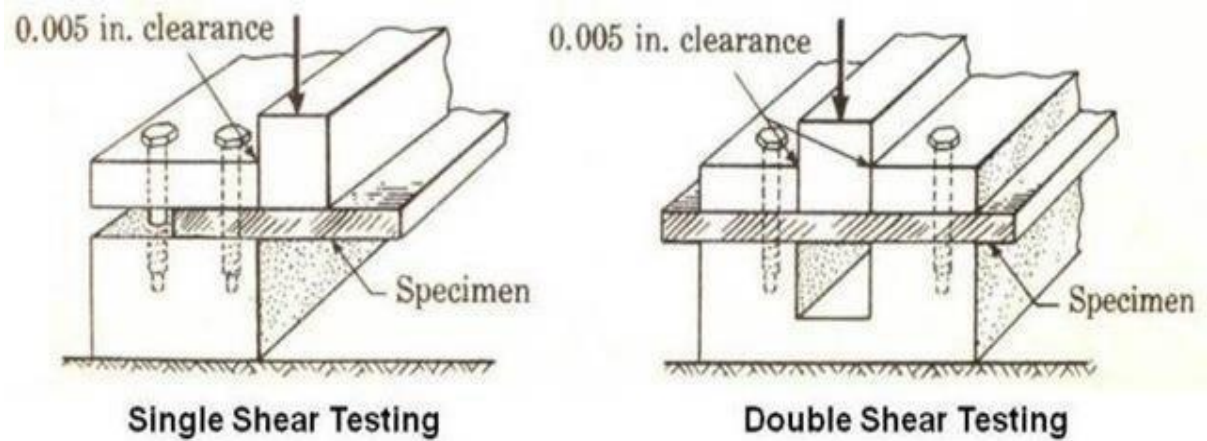

Shear load test

- Testing is performed by applying a load to the material until the materials shears, or slides, apart. The point at which a sample fails is defined as its shear strength.
- Shear strength is calculated by dividing the force required to shear the specimen by the area of the sheared edge.
- The area of the sheared edge is equal to the circumference of the punch multiplied by the thickness of the specimen.

5.8 HARDNESS TESTS:

Hardness is defined as the resistance to indentation. In this method hardness of metals is determined by calculating the resistance offered to the indentation.

They are three types of hardness tests:

1. Brinell Hardness test
2. Rockwell Hardness test
3. Vickers's Hardness test

1. **Brinell hardness Test: (Describe Brinell hardness test to determine the hardness of a metal.)**

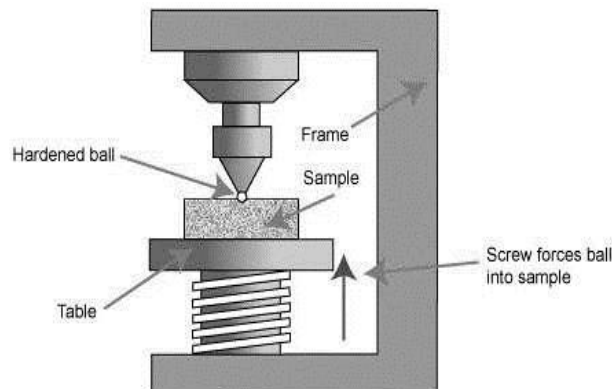

Brinell hardness testing machine

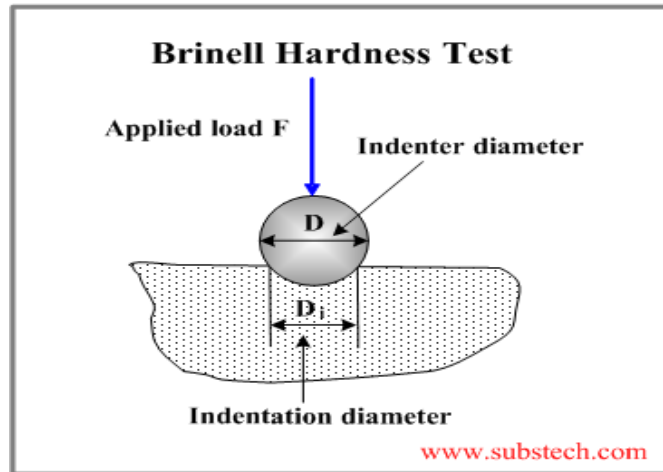

- Brinell hardness test was introduced by J.A Brinell in 1900.
- After polishing the surface, the specimen is fixed on the platform of hardness tester.
- The test is carried out by pressing a hardened steel or tungsten carbide ball of 10mm diameter on the surface of the work piece.
- A load of 3000 kg is applied for hard metals and a load of 500 kg for soft metals.

Brinell Hardness number (BHN)

$$BHN = \frac{P}{A} = \frac{P}{\frac{\pi D}{2} \left(D - \sqrt{D^2 - d^2} \right)}$$

P → Load applied kgf,

D → Diameter of ball, mm

d → Diameter of the Impression, mm

A → Surface area of indentation

Advantages

- Cost of testing is low.
- Skilled operator is not required.
- Soft materials can be tested.
- Hardness of porous powder metallurgy components can be measured.

Limitations of Brinell test:

- The test equipment is very heavy.
- Size of impression is large.
- Not suitable for hard thin pieces & case – hardened parts.

2. **ROCKWELL HARDNESS TEST: (Explain the procedure for performing the Rockwell test.)**

The principle of Rockwell test differs from that of the others. Here, the depth of the impression is related to the hardness rather than the diameter of the diagonal of the impression.

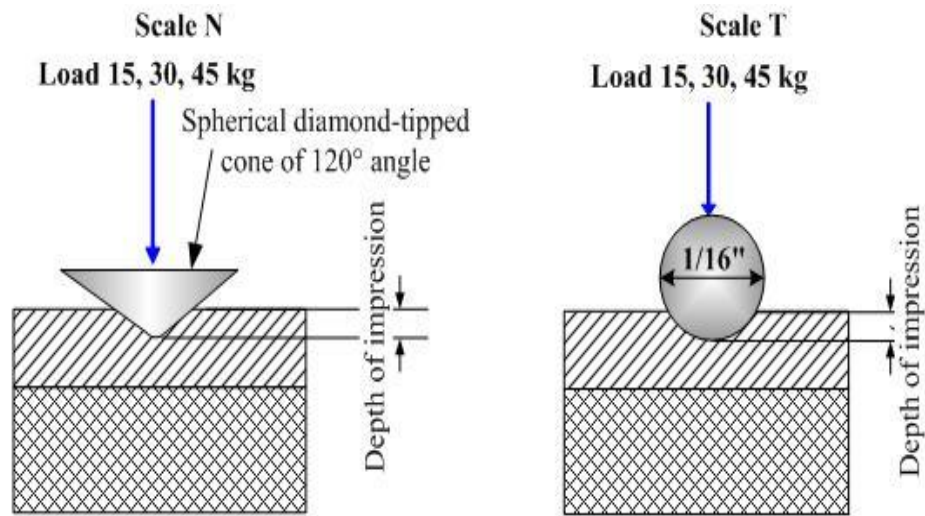

Rockwell Indenter

- The Rockwell test uses a steel ball or a diamond cone with 120⁰ apex angle.
- It has a dial with different scales to read hardness numbers directly.

Here two types of indenters are used for B and C scale:

1. **B-scale:** - (1/16inch diameter steel ball indenter: 100 kg load), used to measure the hardness of non-ferrous metals.
2. **C-scale:** - (1200 diamond cone indenter: 150 kg load), used to measure the hardness of steel.

Precautions:

1. Indenter and anvil on which the test piece is placed should be clean and well seated.
2. Surface to be tested should be clean, dry and free from oxide film.
3. There should be no vibration and shock on the testing machine.
4. Test should be conducted at 27±2°C.

Advantages:

1. Very simple method
2. Hardness can be read directly in a single step.
3. Fast method so suitable for testing mass production materials.
4. Can be used for metallic materials and also plastics.

3. VICKER HARDNESS TEST: (Explain the testing procedure for Vickers hardness test and mention the advantages and limitations.)

The Vickers hardness is similar to the Brinell test with a square based diamond pyramid being used as the indenter.

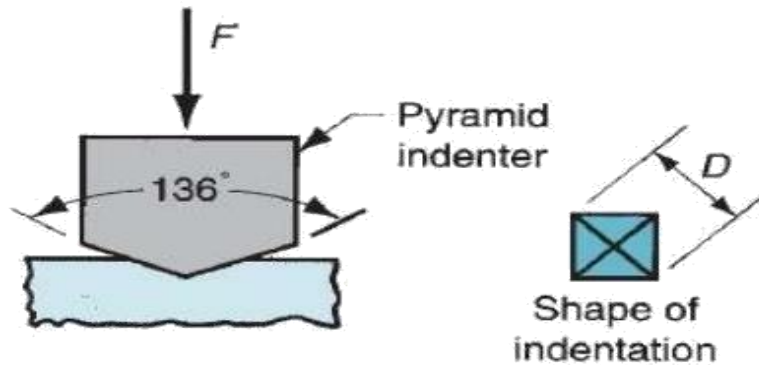

Vickers indenter and impression

- The test is done by pressing the diamond indenter into the surface under testing.
- The indenter is pyramid-shaped, with a square base and an angle of 136 degrees between opposite faces.
- Loads vary from 1 to 100 kgf.
- The full load is normally applied for 10 to 15 seconds.
- the hardness is calculated by the ratio F/A (where F is the force or load, in kgf; and A is the surface area of the indentation, in sq. mm.).
- The hardness value is expressed as Vickers Hardness (HV) or Diamond Pyramid Hardness (DPH)
- The measurements are made using built-in microscopes.

Advantages:

- The indenter used is small in size, which reduces the risk of possible damage to the test material.
- The indenter can be used for any kind of material, irrespective of its hardness.
- The resulting calculations are independent of the size of the indenter.
- A single test force is applied.

Limitations

1. The size of the impression is small.
2. Requires careful surface preparation.
3. It takes relatively long time.

5.9 Micro and nano hardness tests.

- Micro hardness testing deals with very small sample sizes, with a typical load less than 10N. This load is applied to the surface and the indentation is measured for the given pressure.
- The most popular tests for micro hardness are the Vickers test and the Knoop test.

- Their main difference is in the type of indenter used for Nano indentation.
- The Vickers test uses a pyramid-shaped probe, while the Knoop test probe has more of a rectangular edge shape.
- They are used differently depending on the type of indentation that has to be made and measured.

Use of micro hardness testing:

- Micro hardness testing is useful in determining the mechanical properties of metals, ceramics, and composites.

Prerequisites for accurate results in micro hardness tests are,

1. **Proper sample preparation** - like polishing of the sample surface
2. **Sample positioning** - The specimen must be placed in such that the surface is perpendicular to the indenter probe.
3. **Vibration isolation** - Vibration isolation can be achieved by providing an anti-vibration table to mount the micro hardness testers.

3.10 IMPACT TEST: (Compare Charpy and Izod impact test.)

- The capacity of the material to withstand blows without fracture is known as impact strength or impact resistance.
- Impact tests are designed to measure the resistance to failure of a material to a suddenly applied force such as collision, falling object or instantaneous blow.
- The test measures the impact energy, or the energy absorbed prior to fracture.
- Impact energy is a measure of the work done to fracture a test specimen.

Impact test are classified into two types:

1. **Izod Impact test**
2. **Charpy Impact test**

Procedure

Position of the Sample Material

- In the Charpy impact test, the sample lies flat on the test bed as a simple beam.
- Both ends of the specimen get secured before the moment of impact.
- In the Izod impact test, the sample is in a vertical cantilevered position.
- Only the bottom end of the specimen gets locked in place.
- The pendulum hammer strikes the unlocked end of the specimen at a specific point.

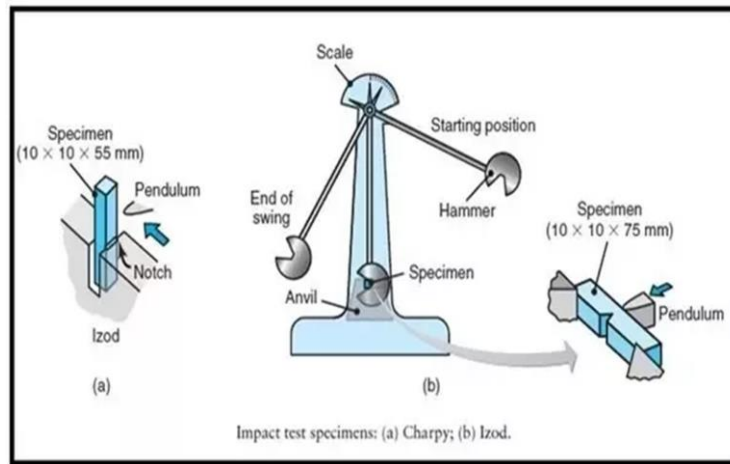

Impact Testing Machine

Method:

- The pendulum is raised and locked at a fixed height.
- The specimen is placed on a support in the striking anvil.
- An indicator or dial is then reset.
- The pendulum is released to impact the specimen.
- After impact, the energy absorbed by the material is computed.
- This is the difference between the height of the pendulum at the start and its height after the impact blow.

Differences between Izod and Charpy Impact tests:

	Izod Impact Test	Charpy Impact Test
Materials Tested	Metals and Plastics	Metals
Position of Specimen	Vertical	Horizontal
Notch-Type	V-Notch	V-Notch and U-Notch
Notch-Face Direction	In front of Striker	Away From Striker
Type of Striker	Farming Hammer	Ball Pin Hammer
Size of Specimen	75mm x 10mm x 10mm	55mm x 10mm x 10mm
Striking Point	Upper Tip of Specimen	Centre of Specimen

3.11 FATIGUE: (Explain the fatigue fracture.)

- Fatigue is the initiation and propagation of cracks in a material due to cyclic loading.
- Fatigue failure is the formation and propagation of cracks due to a repetitive or cyclic load.

Fatigue failure mechanism (*Explain Fatigue failure mechanism.*)

There are three stages of fatigue failure: **initiation, propagation, and final fracture.**

Stage 1: Crack initiation:

- The initial development of a fatigue crack occurs at localized discontinuities in the metal's crystal structure due to stress build-up.
- The generation and movement of discontinuities actually strengthens the metal through plastic deformation.
- Once the metal reaches its plastic deformation limit, the discontinuity becomes a small crack.

Stage 2: Crack propagation:

- Once a crack is initiated, continued cyclical stresses repeat the process, slowly growing the micro-crack.

Stage 3: Failure:

- The final failure event (i.e. catastrophic fracture) can be ductile or brittle, depending on the material, thickness, temperature and the applied stress.
- Fatigue failures typically occur suddenly.
- The fatigue-induced fracture surfaces of a broken component are typically smooth and show no evidence of plastic deformation.

Fatigue Test

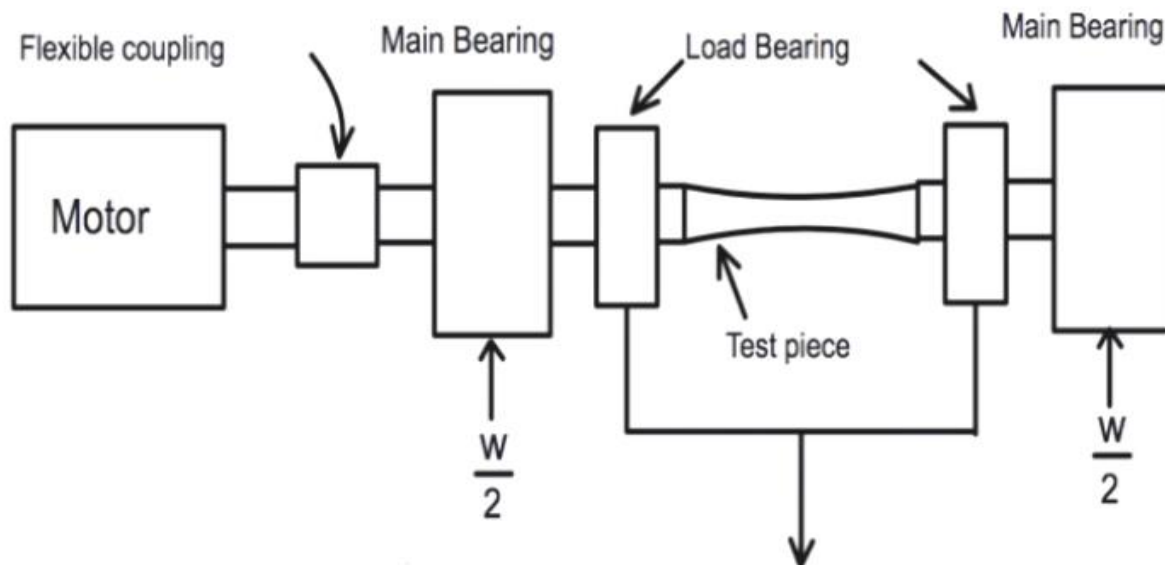

Fatigue test experimental setup.

Rotating beam fatigue testing machine

Principle: It is performed by applying alternate loading of the specimen.

Construction:

- A test specimen is placed in the machine.
- A steady bending is applied to rotating shaft through ball bearing in load hanger.
- Revolution counter is used to measure the number of rotation.

Working:

- As the shaft rotates the specimen is applied by alternate compressive and tensile stresses.

- The number of cycle of stress(N) is equal to the number of rotation.
- The test is performed for various cycle of stresses.

Fatigue curve:

- From the experiment a graph is drawn between log N & stress (S).
- First stress decreases as the number of cycle increases then after sometimes remains constant.
- This steady value is called endurance limit.

S-N CURVE:

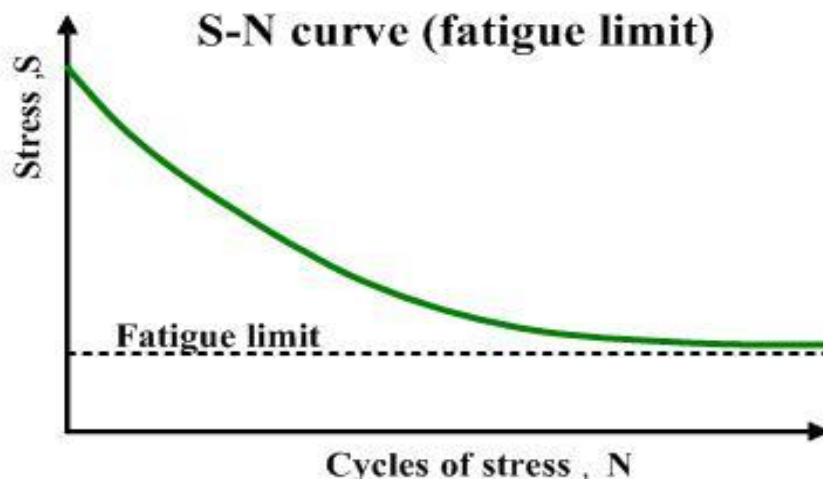

S-N Curve

where,

S → Stresses

N → Number of revolutions

- Several specimens are tested one by one above, at gradually decreasing stress levels.
- The number of cycles to failure in each is noted.
- The results are presented as a graph, with the stress level (S) plotted versus the number of cycles to failure. Such as plot is known as S-N curve.

Two important information are obtained from S-N curve:

i. Endurance limit

ii. Fatigue life

i) Endurance limit: (Define endurance limit in fatigue test.)

It is defined as the maximum stress that can be applied repeatedly for infinite number of times without failure of the material.

ii) Fatigue life:

It tells how long a component survives at a particular stress level.

5.12 CREEP TEST: (Define creep fracture.)

- The continuous deformations of a metal under a steady load is known as creep.
- When a material is subjected to static loads at higher temperatures for a long period, the materials deforms under stresses well below the yield strength.

Procedure

- The specimen is subjected to a constant load by means of dead weights and levers.
- A tubular, electrically heated furnace surrounds the specimen.

- The ends of the specimen are sometimes fitted with thermocouple for the measurement of temperature or to maintain a constant temperature.
- The total creep or percentage elongation can be measured by an extensometer and the percentage elongation is plotted against time for the entire duration of the test.

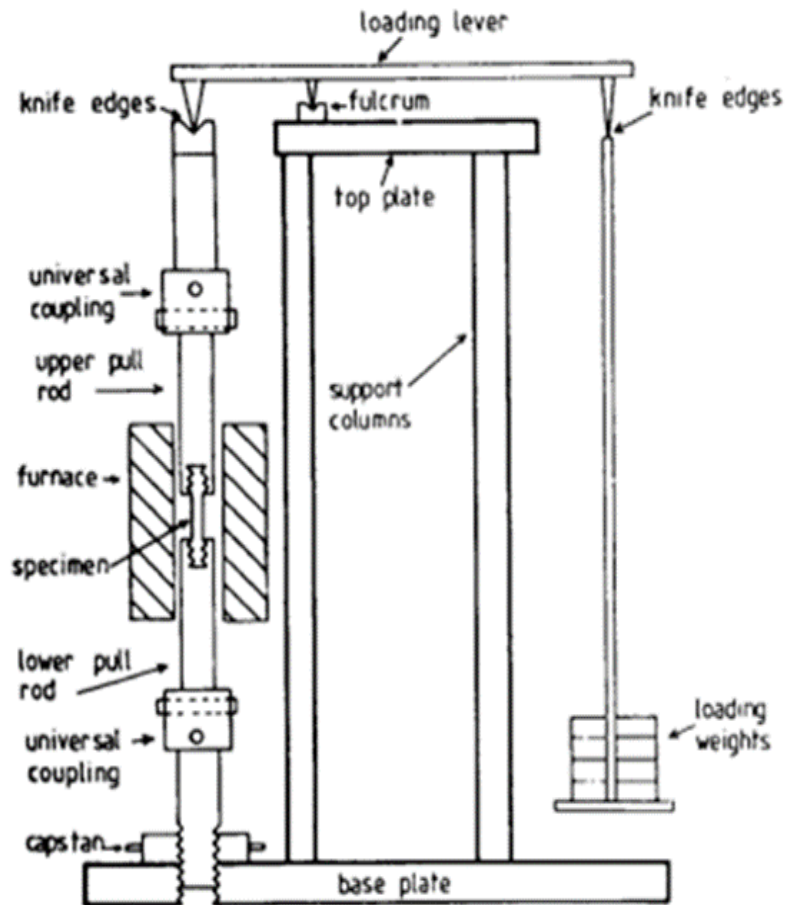

(Draw a typical creep curve and explain the various stages of creep.)

Mechanism of creep failure

Creep failure occurs in three stages:

1. Primary, or Stage I
2. Secondary, or Stage II
3. Tertiary, or Stage III

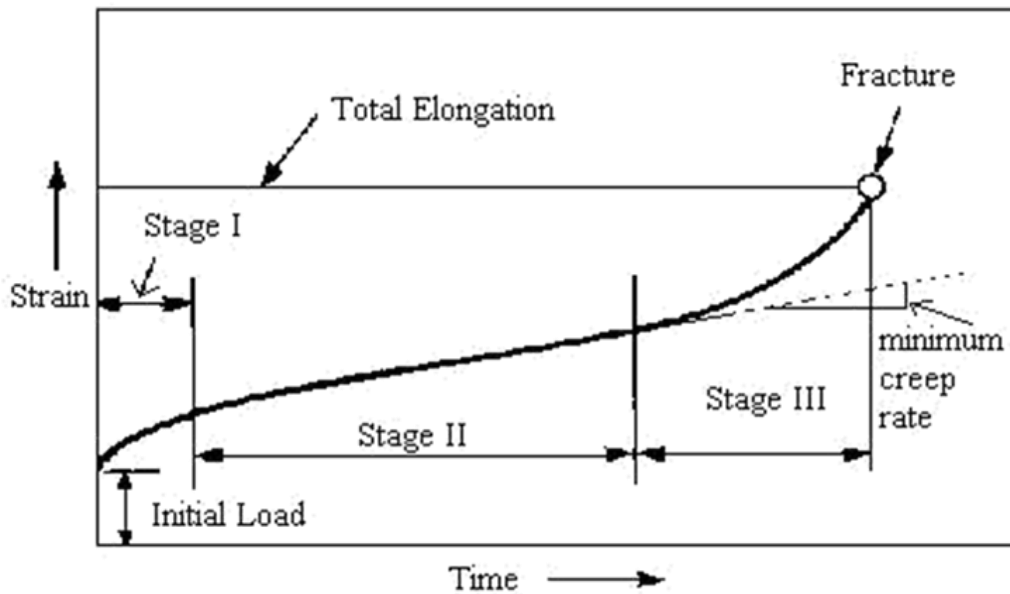

Primary creep

- Primary creep occurs at the beginning of the tests, and creep is mostly transiently, not at a steady rate.
- Resistance to creep increases until Stage II is reached.

Secondary creep

- The rate of creep becomes roughly steady.
- This stage is often referred to as steady state creep.

Tertiary creep

- In this stage, creep rate increases with time until fracture occurs.
- Generally, the tertiary creep occurs due to necking of the specimen or grain boundary sliding.
- Creep curve is plotted between strain and time in hours.

UNIT – 5
MECHANICAL PROPERTIES AND DEFORMATION MECHANISMS
PART: A

1. Define the term elasticity and plasticity.

Elasticity: It is the property of a material by virtue of which it is able to retain its original shape and size after the removal of the load.

Plasticity: It is the property of a material by virtue of which permanent deformation takes place, whenever it is subjected to the action of external force.

2. What are the factor affecting mechanical properties?

- Grain size
- Heat treatment
- Atmospheric exposure
- Low and high temperature

3. Classify the different hardness testing methods. [N/D'16]

1. Rockwell hardness test
2. Brinell hardness test
3. Vickers hardness test

4. What are the different types of fracture?

- Ductile Fracture
- Brittle Fracture

5. Why impact specimen is notched?

The impact specimens are notched because the impact test also indicates the notch sensitivity of material.

6. Define creep.

Creep is defined as the slow and progressive deformation of materials with time under a constant stress at temperature approximately above $0.4 T_m$. Where T_m is melting point of metal in $^{\circ} K$.

7. Define endurance limit in fatigue test.

The value of limiting stress below which a load may be applied repeatedly for an indefinitely large of time is called as endurance limit for fatigue test.

8. Distinguish between slip and twinning

It is defined as the shear transformation, which moves the atoms over a number of interatomic distances relative to their initial position.

It is the plastic deformations which takes place along two planes due to set of forces acting on a given metal.

10. Distinguish between elasticity and plasticity. [M/J'16]

Elasticity	plasticity
Deformation disappears when external load is removed	Permenant deformation occurs.
Obeys hook's law	Does not obey hook's law

11. What are the factors affecting creep?

Grain size
 Thermal stability

Chemical reaction
 Prior strain

PART: B

1. Explain the mechanism of plastic deformation by slip and twinning with neat sketch. [N/D'15]
2. Differentiate between ductile fracture and brittle fracture.
3. Write down the procedure for preparing Charpy and Izod specimens for impact testing and also explain how testing is performed? (N/D2009)
4. Explain the testing procedure for determining hardness of materials. [M/J'16]
 - Rockwell hardness test (8)
 - Brinell hardness number (4)
 - Vickers hardness test (4)
5. Sketch and describe the fatigue test and fatigue failure mechanism.
6. Draw creep curve and explain the different stages of creep damage. [N/D'16]