

**UNIT – 1****ELECTRICAL PROPERTIES OF MATERIALS****CONTENTS****1.5. Classical Free Electron theory****1.5.1. Postulates of classical free electron theory****1.5.2. Electrical Conductivity****1.5.3. Thermal Conductivity****1.5.4 Wiedemann – Franz Law****1.5.5. Lorentz number****1.5.6. Success of classical free electron theory****1.5.7. Drawbacks of classical free electron theory****1.5. Classical Free Electron theory**

After the discovery of electron, Drude and Lorentz proposed classical free electron theory in 1900. It is a macroscopic theory and explains electrical and thermal properties of solids based on classical laws.

**1.5.1. Postulates of classical free electron theory****In the absence of electrical field**

- ❖ The electrons are moves freely in the boundaries of the metal, similar to the gas molecules moving in a vessel.
- ❖ The forces between the conduction electrons and ion core in neglected.
- ❖ The electrons possess kinetic energy only.
- ❖ Free electrons are elastically collides with each.

**In the presence of field**

- ❖ The free electrons move in the opposite direction to the applied electrical field direction.
- ❖ It is obey the classical Maxwell-Boltzmann distribution of velocities.
- ❖ All free electrons gain equal amount of thermal energy and involved for thermal conduction.

**Mean free path**

The average distance travelled by a free electron in any two successive collisions is known as mean free path.

$$\lambda = V_d \tau_c$$

### Collision time

The average time taken by a free electron in any two successive collisions is called collision time.

$$\tau_c = \lambda / V_d$$

### Relaxation time

Average time taken by a free electron to reach its equilibrium state from disturbed state due to the application of an electrical field is known relaxation time. It is approximately equal to  $10^{-14}$  s.

### Mobility

The drift velocity acquired by the electron per unit applied electrical field to it.

$$\mu = \frac{V_d}{E} \quad (m^2 V^{-1} S^{-1})$$

### 1.5.2. Electrical Conductivity

The amount of electrical charges conducted per unit time across unit area per unit applied electrical field is known as electrical conductivity.

$$\sigma = \frac{Q}{tAE}$$

$$\sigma = \frac{I}{AE} \quad (\because Q/t = I)$$

$$\sigma = \frac{J}{E} \quad (\because I/A = J)$$

$$J = \sigma E$$

### Derivation of Electrical Conductivity of metals

Consider a metal conductor of 'XY' and 'E' is the applied electric field to it. The electron moves in opposite directions to the applied field with a velocity  $V_d$ .

Let 'n' be the number of free electrons per unit volume.

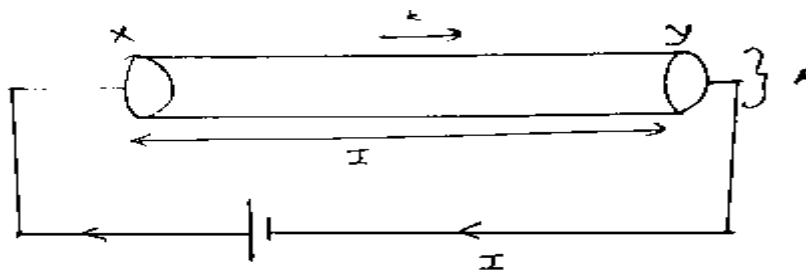

Fig 1.5.1 Movement of free electrons in a metal rod

Current density of a conducting material is given by,

$$J = enV_d \dots\dots\dots (1)$$

Force experienced by the electron is

$$F = -eE \dots\dots\dots (2)$$

This force accelerates the electron

$$a = \frac{\text{Drift Velocity}}{\text{Collison time}}$$

$$a = \frac{V_d}{\tau}$$

$$V_d = a\tau \dots\dots\dots (3)$$

From the Newton's second law of motion, the force on the electron,

$$F = ma \dots\dots\dots (4)$$

Equate equations (2) and (4) we have,

$$eE = ma$$

$$a = \frac{eE}{m} \dots\dots\dots (5)$$

Substitute Eqn. (5) in Eqn. (3) we get,

$$V_d = \frac{eE\tau}{m} \dots\dots\dots (6)$$

Substituting eqn. (6) in eqn. (1) we have,

$$J = \frac{(e)n(eE\tau)}{m}$$

$$J = \frac{nEe^2\tau}{m}$$

$$\frac{J}{E} = \frac{ne^2\tau}{m}$$

$$\sigma = \frac{ne^2\tau}{m} \dots\dots\dots (7) (\because \sigma = J/E)$$

We find that with increase of electron concentrations, the conductivity 'σ' is increases. As 'm' increases the motion of the electron becomes slow and hence the conductivity 'σ' decreases.

**Co-efficient of electrical conductivity**

The quantity of electricity flowing per unit area per unit time maintained at unit potential gradient.

$$J = \sigma E$$

$$\frac{I}{A} = \sigma E$$

If  $A=1$ ;  $E=1$ , then,

$$I = \sigma$$

### 1.5.3. Thermal Conductivity

The amount of heat conducted by the conductor is

$$Q = KA \frac{dT}{dx} t$$

$$K = \frac{Q}{A \left(\frac{dT}{dx}\right) t} \dots\dots\dots (1)$$

Where,

$K \rightarrow$  is the thermal conductivity

$A \rightarrow$  is the area of cross section

$t \rightarrow$  is the time of flow of heat

$\frac{dT}{dx} \rightarrow$  Temperature gradient

The amount of heat conducted per unit time per unit area of cross section per unit temperature gradient.

If  $A = 1$ ;  $t = 1$ , then eqn. (1) becomes

$$K = \frac{Q}{\frac{dT}{dx}}$$

$$Q = K \frac{dT}{dx} \dots\dots\dots (2)$$

### Expression for thermal conductivity of a metal

Consider a metal rod 'AB' with the length of ' $\lambda$ '. Let 'A' be at higher temperature and 'B' at a low temperature. Now, heat flows from A to B by the free electrons.

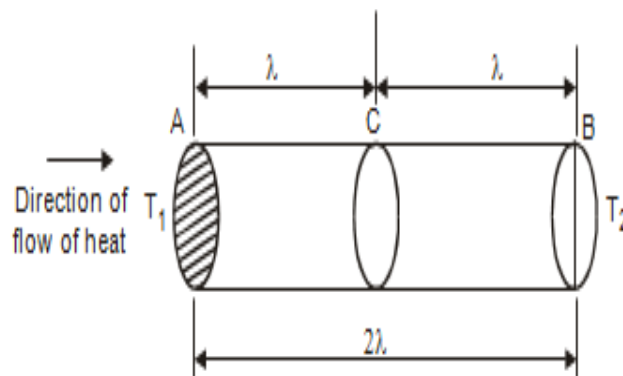

Fig 1.5.2 Thermal conductivity of a metal

Free electron per unit volume =  $n$

Average velocity of the electrons =  $v$

Average kinetic energy of electron at 'A' is  $= \frac{3}{2} K_B T$  ..... (3)

Where,

$K_B \rightarrow$  is the Boltzmann constant

$T \rightarrow$  is the temperature at A

Average kinetic energy of an electron at 'B' is  $= \frac{3}{2} K_B (T - dT)$  ..... (4)

The excess of kinetic energy carried by the electron from A to B is,

$$\begin{aligned} &= \frac{3}{2} K_B T - \frac{3}{2} K_B (T - dT) \\ &= \frac{3}{2} K_B T - \frac{3}{2} K_B T + \frac{3}{2} K_B dT \\ &= \frac{3}{2} K_B dT \quad \dots \dots \dots (5) \end{aligned}$$

Let us assume that, there is an equal probability for the electrons to move in all six directions shown in given figure.

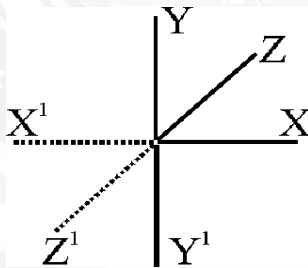

Each electrons travels with thermal velocity ' $v$ ' and ' $n$ ' is the free electrons per unit volume. Then  $1/6 nv$  electrons travel in any one of the directions per unit area per unit time.

Number of electrons crossing per unit area per unit time A to B is

$$= \frac{1}{6} nv$$

The excess of energy carried from A to B per unit area in unit time is

$$\begin{aligned} &= \frac{1}{6} nv \times \frac{3}{2} K_B dT \\ &= \frac{1}{4} nv K_B dT \quad \dots \dots \dots (6) \end{aligned}$$

Similarly, the deficient of energy carried from B to A per unit area per unit time

$$= -\frac{1}{4} nv K_B dT \quad \dots \dots \dots (7)$$

Hence, the net amount of energy transferred from A to B per unit area per unit time.

$$Q = \frac{1}{4}nvK_B dT - \left(-\frac{1}{4}nvK_B dT\right)$$

$$Q = \frac{1}{2}nvK_B dT \dots\dots\dots (8)$$

Compare eqn. (2) and (8), we get

$$K \frac{dT}{dx} = \frac{1}{2}nvK_B dT$$

$$K = \frac{1}{2}nvK_B dx$$

$$K = \frac{1}{2}nvK_B \lambda \dots\dots\dots (9) \quad (\because \lambda = dx)$$

We know that for the metals, the collision time is equal to the relaxation time.

$$\lambda = v\tau \dots\dots\dots (10)$$

Substitute eqn. (10) in eqn. (9) we have,

$$K = \frac{1}{2}nvK_B v\tau$$

$$K = \frac{1}{2}nv^2K_B \tau \dots\dots\dots (11)$$

This is the expression of thermal conductivity and it is directly proportional to the square of the velocity of the electrons.

**1.5.4. Wiedemann – Franz Law**

The ratio between the thermal conductivity and electrical conductivity of a metal is directly proportional to the absolute temperature of the metal. This ratio is a constant for all metals at given temperature.

$$\frac{K}{\sigma} \propto T$$

$$\frac{K}{\sigma} = LT$$

Where, ‘L’ is proportionality constant. It is known as Lorentz number. Its value is  $2.44 \times 10^{-8} \text{W}\Omega\text{K}^{-2}$  at  $T=293 \text{ K}$ .

From classical theory, the electrical thermal conductivity of a metal is given as

$$\sigma = \frac{ne^2\tau}{m} \dots\dots\dots (1)$$

$$K = \frac{1}{2} n v^2 K_B \tau \dots\dots\dots (2)$$

$$\frac{K}{\sigma} = \frac{\left(\frac{1}{2} n v^2 K_B \tau\right)}{\frac{n e^2 \tau}{m}}$$

$$\frac{K}{\sigma} = \frac{\frac{1}{2} m v^2 K_B}{e^2} \dots\dots\dots (3)$$

We know that the kinetic energy of the electron is

$$\frac{1}{2} m v^2 = \frac{3}{2} K_B T \dots\dots\dots (4)$$

Substituting eqn. (4) in eqn.(3), we have

$$\frac{K}{\sigma} = \frac{3 K_B T K_B}{2 e^2}$$

$$\frac{K}{\sigma} = \frac{3 K_B^2 T}{e^2}$$

$$\frac{K}{\sigma} = \frac{3}{2} \left(\frac{K_B}{e}\right)^2 T$$

$$\frac{K}{\sigma} = L T \dots\dots\dots (5) \left(\because L = \frac{3}{2} \left(\frac{K_B}{e}\right)^2\right)$$

Where ‘L’ is a constant and it is known as **Lorentz number**. According to this law it can be concluded that if a metal has high thermal conductivity, it will also have high electrical conductivity.

**1.5.5. Lorentz number**

The ratio between the thermal conductivity (K) to the product electrical conductivity (σ) and absolute temperature (T) of the metal is a constant. The constant value is known as Lorentz number.

$$L = \frac{K}{\sigma T} \dots\dots\dots (1)$$

According to classical theory,

$$L = \frac{3}{2} \left(\frac{K_B}{e}\right)^2 \dots\dots\dots (2)$$

Substitute the values of  $K_B = 1.38 \times 10^{-23} \text{ JK}^{-1}$  and  $e = 1.602 \times 10^{-19} \text{ C}$  in equation (2), we have,

$$L = \frac{3}{2} \left( \frac{1.38 \times 10^{-23}}{1.602 \times 10^{-19}} \right)^2$$

$$L = 1.12 \times 10^{-8} W \Omega K^{-2} \dots \dots \dots (3)$$

Hence, it was found that the classical value of Lorentz number is only half of the experimental value, i.e.,  $L = 2.44 \times 10^{-8} W \Omega K^{-2}$ . This discrepancy in the experimental and theoretical value of Lorentz number is the failure of classical theory. This was rectified by quantum theory.

According to the quantum theory, electrons near the Fermi level alone contribute towards thermal and noble conductions. Using quantum free electron theory model, the electronic specific heat value is given by

$$C_v = \frac{n\pi^2 K_B^2 T}{mv^2} \dots \dots \dots (4)$$

Thermal conductivity is

$$K = \frac{1}{3} C_v v^2 \tau \dots \dots \dots (5)$$

Substitute equation (4) in (5) we get,

$$K = \frac{n\pi^2 K_B^2 T v^2 \tau}{3mv^2}$$

$$K = \frac{n\pi^2 K_B^2 T \tau}{3m} \dots \dots \dots (6)$$

The electrical conductivity is

$$\sigma = \frac{ne^2 \tau}{m} \dots \dots \dots (7)$$

From equations (6) and (7) we get,

$$\frac{K}{\sigma} = \frac{\frac{n\pi^2 K_B^2 T \tau}{3m}}{\frac{ne^2 \tau}{m}}$$

$$\frac{K}{\sigma} = \frac{m n \pi^2 K_B^2 T \tau}{3 m n e^2 \tau}$$

$$\frac{K}{\sigma} = \frac{\pi^2}{3} \left( \frac{K_B}{e} \right)^2 T$$

$$\frac{K}{\sigma T} = \frac{\pi^2}{3} \left( \frac{K_B}{e} \right)^2$$

$$\frac{K}{\sigma T} = L \dots \dots \dots (8)$$



$$L = \frac{\pi^2}{3} \left( \frac{K_B}{e} \right)^2$$

Substitute the values of  $K_B = 1.38 \times 10^{-23} \text{ JK}^{-1}$  and  $e = 1.602 \times 10^{-19} \text{ C}$  in equation (2), we have,

$$L = \frac{(3.14)^2}{3} \left( \frac{1.38 \times 10^{-23}}{1.602 \times 10^{-19}} \right)^2$$

$$L = 2.44 \times 10^{-8} \text{ W}\Omega\text{K}^{-2} \dots\dots\dots (9)$$

This value is in good agreement with the experimental value. The Widemann Franz law is not appreciable at very low temperature.

**1.5.6. Success of classical free electron theory**

1. It verifies ohm's law
2. It explains the electron and thermal conductivity.
3. It derives Widemann – Franz law.
4. It explains optical properties of metals.

**1.5.7. Drawbacks of classical free electron theory**

1. It is failed to explain photoelectric effect, Compton Effect, paramagnetism, ferromagnetism and black body radiation.
2. It is a macroscopic theory.
3. It cannot explain the electrical conductivity of semiconductors or insulators using this model.
4. It states that all the free electrons will absorb energy, but quantum theory states that only free electrons will absorb energy.
5. In classical free electron theory, theoretical and experimental value of Lorentz number is not matched. It is rectified by quantum theory.
6. Theoretical and experimental value of specific heat ( $4.5R \neq 3R$ ) and electronic specific heat ( $3/2 R \neq 0.01R$ ) is not match