

3.2 Thermal Power Plant:

- Solar thermal power plant comprises power plants which first convert solar radiation into heat. The resulting thermal energy is subsequently transformed into mechanical energy by a thermal engine, and then converted into electricity.
- For thermodynamic reasons high temperatures are required to achieve the utmost efficiency. Such high temperatures are reached by increasing the energy flux density of the solar radiation incident on a collector.

According to the type of solar radiation concentration, solar thermal power plants are subdivided into:

- Concentrating (point and line focusing systems)
- Non-concentrating systems

The former Classification can be further made according to:

- type of receiver of the solar radiation
- the heat transfer media and the heat storage system
- additional firing based on fossil fuel energy

Concentrating systems concepts:

- ✓ Solar tower power plants (i.e. central receiver systems) as point focusing power plants
- ✓ Dish/Stirling systems as point focusing power plants
- ✓ Parabolic trough and Fresnel trough power plants as line focusing power plants
- ✓ Concentrating collectors can reach temperature levels similar to that of existing fossil-fuel fired thermal power stations (e.g. power plants fired with coal or natural gas)

Non-concentrating systems concepts:

- ✓ Solar updraft tower power plants
- ✓ solar pond power plants

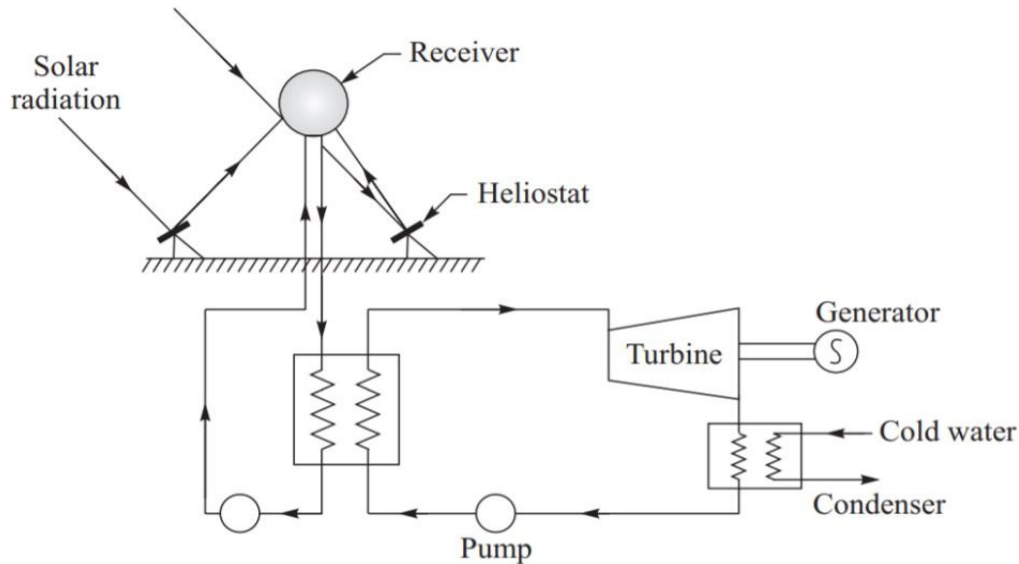

Figure: 3.2.1

[Source: "Solar Photovoltaics: Fundamentals, Technologies and Applications" by ChetanSingh Solanki, Page: 202]

- ◆ Solar thermal power plants are electricity generation plants that utilize energy from the Sun to heat a fluid to a high temperature. This fluid then transfers its heat to water, which then becomes superheated steam. This steam is then used to turn turbines in a power plant, and this mechanical energy is converted into electricity by a generator.
- ◆ This type of generation is essentially the same as electricity generation that uses fossil fuels, but instead heats steam using sunlight instead of combustion of fossil fuels. These systems use solar collectors to concentrate the Sun's rays on one point to achieve appropriately high temperatures.
- ◆ There are two types of systems to collect solar radiation and store it: passive systems and active systems. Solar thermal power plants are considered active systems. These plants are designed to operate using only solar energy, but most plants can use fossil fuel combustion to supplement output when needed.
- ◆ Some of the drawbacks include the large amount of land necessary for these Plants to operate efficiently
- ◆ As well, the water demand of these plants can also be seen as an issue, as the production of

enough steam requires large volumes of water. A final potential impact of the use of large focusing mirrors is the harmful effect these plants have on birds.

- ◆ Birds that fly in the way of the focused rays of Sun can be incinerated. Some reports of bird deaths at power plants such as these amounts the deaths to about one bird every two minutes.

3.2.1 Facts about Solar Thermal Energy:

- Solar thermal energy has been used in various ways for millennia, ranging from simple fire starting with a pocket mirror to solar architecture to capture heat in buildings.
 - 48% of the the sun's energy is in the infrared spectrum, invisible to the human eye, as heat.
 - Solar thermal collectors can employ (absorb) nearly the entire solar spectrum
 - The sun is the most abundant and reliable source of energy
 - Financially, solar thermal energy conversion systems have reached grid- parity in many locations
- ➔ Currently, we (humans) use an abundance of fossil fuels for much of our heat needs.
 - ➔ While in the long run our society will switch to the source of all of those fossil fuels (the sun), the reality is that most of you have probably not experienced the direct impact of a solar thermal energy conversion system on your life.
 - ➔ The truth is that we can do everything that we currently do in our society with solar energy. Much of the burden can be carried by solar thermal solutions.
 - ➔ One terrific modern day example of a solar thermal energy system is the Drake Landing Solar Community in Alberta, Canada, where 95% of the the community's heating needs are supplied by on-site solar thermal collection and a connected seasonal thermal energy storage system. Our society uses a lot of heat.
 - ➔ We need to keep working to make solar thermal energy solutions make sense andwork well in more places whenever possible.

3.2.2 Process of solar thermal power generation:

- ✿ Concentrating solar radiation by means of a collector system
- ✿ Increasing radiation flux density (i.e. concentrating of the solar radiation onto a receiver)
- ✿ Absorption of the solar radiation (i.e. conversion of the radiation energy into thermal energy (i.e. heat) inside the receiver)
- ✿ Transfer of thermal energy to an energy conversion unit
- ✿ Conversion of thermal energy into mechanical energy using a thermal engine (e.g. steam turbine)
- ✿ Conversion of mechanical energy into electrical energy using a generator

3.2 (a) SOLAR TOWER POWER STATION:

Main principles and components:

- Central receiver systems in the tower
- Mirrors tracking the course of the sun in two axes (Heliostats)
- Heliostats reflect the direct solar radiation onto a receiver, centrally positioned on a tower.
- In the receiver, radiation energy is converted into heat and transferred to a heat transfer medium (e.g. air, liquid salt, water/steam).
- This heat drives a conventional thermal engine.
- To ensure constant parameters and a constant flow of the working medium also at times of varying solar radiation, either a heat storage can be incorporated into the system or additional firing using e.g. fossil fuels (like natural gas) or renewable energy (like biofuels) can be used.

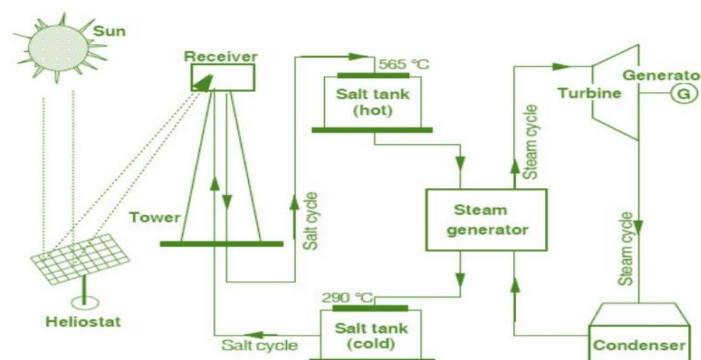

Renewable Energy System

Figure 3.2.2

[Source: "Solar Photovoltaics: Fundamentals, Technologies and Applications" by Chetan Singh Solanki, Page: 222]

Heliostats:

- ➔ Heliostats are reflecting surfaces provided with a two-axis tracking system which ensures that the incident sunlight is reflected towards a certain target point throughout the day.
- ➔ Heliostats commonly concentrate sunlight by means of a curved surface or an appropriate orientation of partial areas, so that radiation flux density is increased.

Heliostats consist of

- ❁ the reflector surface (e.g. mirrors, mirror facets, other sunlight-reflecting surfaces)
- ❁ a sun-tracking system provided with drive motors
- ❁ foundations and control electronics. The individual heliostat's orientation is commonly calculated on the basis of:
 - the current position of the sun
 - the spatial position of the heliostats
 - the target point.
- ❁ The target value is communicated electronically to the respective drive motors via a communication line.
- ❁ This information is updated every few seconds.
- ❁ The concentrator surface size of currently available heliostats varies between 20 and 150 m² ; to date, the largest heliostat surface amounts to 200 m².



System

Faceted glass/metal heliostat

Figure: 3.2.3

[Source: "Solar Photovoltaics: Fundamentals, Technologies and Applications" by ChetanSingh Solanki, Page: 204]

metal membrane heliostat

Figure: 3.2.4

- ❁ The heliostat field accounts for about half the cost of the solar components of such a power plant.
- ❁ This is why tremendous efforts have been made to develop heliostats of good optical quality, high reliability, long technical life and low specific costs.
- ❁ Due to economic considerations there is a tendency to manufacture heliostats with surfaces ranging between 100 m² and 200 m² and possibly beyond.
- ❁ However, there are also approaches to manufacture smaller heliostats to reduce costs by efficient mass-production.

Controller:

- ❁ Heliostats are usually centrally controlled and centrally supplied with electrical energy.
- ❁ As an alternative, autonomous heliostats have been developed which are controlled locally.
- ❁ There, the energy required for the control processor and the drives is provided by photovoltaic cells mounted parallel to the reflector surface.

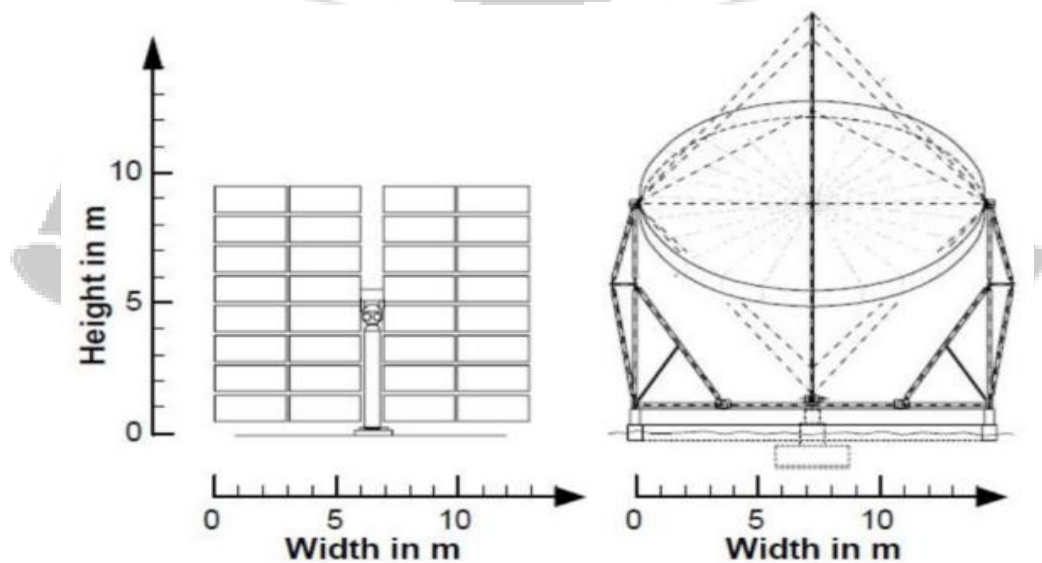

Figure 3.2.5

[Source: "Solar Photovoltaics: Fundamentals, Technologies and Applications" by ChetanSingh Solanki, Page: 205]

Heliostat fields:

The layout of a heliostat field is determined by technical and economic optimization:

- ✿ Heliostats located closest to the tower present the lowest shading,
- ✿ Heliostats placed north on the northern hemisphere (or south on the southern hemisphere) show the lowest cosine losses.
- ✿ Heliostats placed far off the tower, by contrast, require highly precise tracking and, depending on the geographic location, have to be placed farther from the neighboring heliostats.
- ✿ The cost of the land, the tracking and the orientation precision thus determine the economic size of the field.
- ✿ **Cosine losses:** representing the difference between the amount of energy falling on a surface pointing at the sun, and a surface parallel to the surface of the earth.

Tower:

- ✿ The height of the tower, on which the receiver is mounted, is also determined by technical and economic optimization.
- ✿ Higher towers are generally more favorable, since bigger and denser heliostat fields presenting lower shading losses may be applied.
- ✿ However, this advantage is counteracted by the high requirements in terms of tracking precision placed on the individual heliostats, tower and piping costs as well as pumping and heat losses.
- ✿ Common towers have a height of 80 to 100 m. Lattice as well as concrete towers are applied.

RECEIVER:

Receivers of solar tower power stations serve to transform the radiation energy,diverted and concentrated by the heliostat field, into technical useful energy.

Nowadays, common radiation flux densities vary between 600 and 1,000kW/m².

Receivers classification according to:

- ✿ the applied heat transfer medium (e.g. air, molten salt, water/steam, liquidmetal)
- ✿ the receiver geometry (e.g. even, cavity, cylindrical or cone-shaped receivers)

According to heat transfer medium:

Water/steam receiver

- ✿ Salt receiver
- ✿ Open volumetric air receiver Closed
- ✿ (pressurized) air receivers

Water/steam receiver:

- ✿ first solar tower power stations
- ✿ Similar to conventional steam processes, water is vaporized and partly superheated in such a heat exchanger (i.e. tube receiver).
- ✿ Since superheating is prone to unfavorable heat transmission, and due to thefact that start-up operation or part-load operation require complicated controls, this approach is currently not developed further.

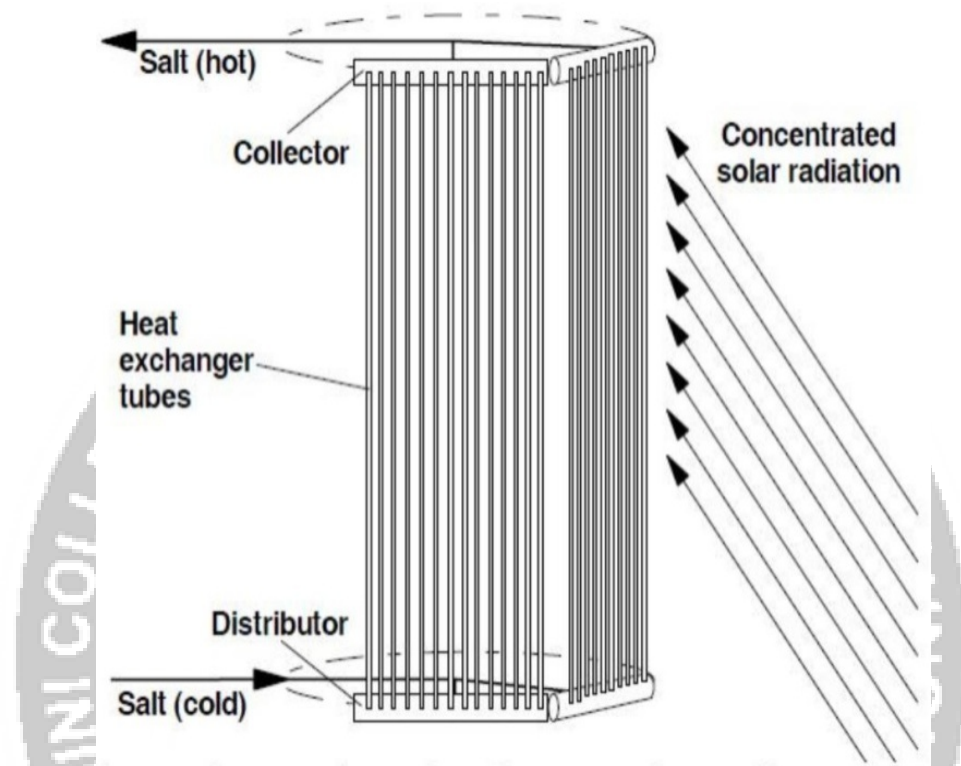

Figure 3.2.6

[Source: "Solar Photovoltaics: Fundamentals, Technologies and Applications" by ChetanSingh Solanki, Page: 209]



Salt receiver:

- ✿ The difficulties of heat transmission with a vertical tube receiver, exemplarily shown in the previous figure, can partly be avoided by an additional heat transfer medium circuit.
- ✿ The heat transfer medium applied for this secondary circuit should have a high heat capacity and good thermal conduction properties.
- ✿ Molten salt consisting of sodium or potassium nitrate (NaNO_3 , KNO_3) complies with these requirements.
- ✿ One disadvantage of all such salt receiver:
 - ✿ the salt must be kept liquid also during idle times when there is no solar radiation. This requires to either heat the whole part of the installation that is filled with salt (including, among other components, tanks, tubes, valves) and thus increases the energy consumption of the plant itself, or to completely flush the salt circuit.
 - ✿ The highly corrosive gas phase of the used salts also has a detrimental effect, since, for certain operations, undesired evaporation of small amounts of salt due to local overheating cannot be entirely ruled out.

Open volumetric air receiver:

- ✿ Such volumetric receivers are characterized by a high ratio of absorbing surface to flow path of the absorbing heat transfer medium air.
- ✿ **Principle:** Ambient air is sucked in by a blower and penetrates the radiated absorber material. The air flow absorbs the heat, so that those absorber areas facing the heliostat are cooled by the inflowing air.

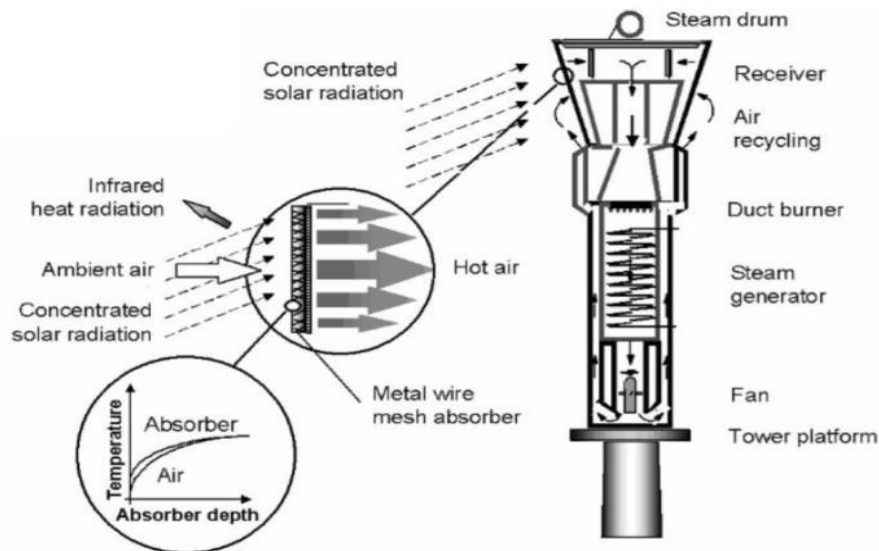

Figure 3.15

Closed (pressurized) air receivers:

- ❁ Receivers of solar tower power plants may also be designed as closed pressurized receivers.
- ❁ The aperture of such receivers is closed by a fused quartz window, so that the working medium air may be heated under overpressure and may, for instance, be directly transferred to the combustor of a gas turbine.
- ❁ E.g: a group of closed air receivers of a heat capacity of up to 1,000 kW has been tested at 15 bar.
- ❁ The obtained air outlet temperatures are slightly above 1,000 °C For
- ❁ commercial applications several module groups may be added.

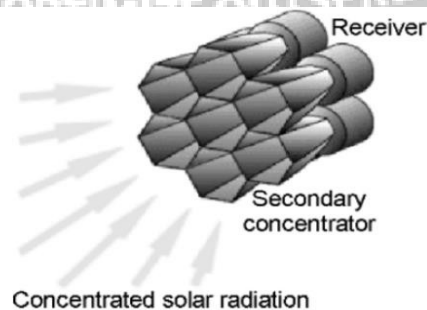

Figure 3.16



