

4.1 Introduction

In general, many organic materials are used in engineering industries. Plastics are belonged to the family of organic materials. The plastics are attained a firm place today. Main characteristics of plastics are no problem for designing it. Organic materials are those materials obtained directly from carbon and chemically combined with oxygen, hydrogen and other non-metallic compounds.

These organic materials are classified into two types. They are

1. Natural organic materials
2. Synthetic organic materials.

1. Natural organic materials

The wood, coal, petroleum and natural rubber are under the categories of natural organic.

2. Synthetic organic materials

The plastics, synthetic rubbers, ceramics glass are under the categories of synthetic organic. Technically, these organic materials are called polymers.

4.1.1 Polymers

The term polymer has its base in Greek terminology, where 'Poly' means 'Many' and 'Mars' means 'Parts'. The term polymer stands to represent a substance built up several repeating 'units'.

A single unit is called as 'monomer'. The monomers are small molecules. A polymer is made up of thousands of monomer joined together to form a large molecule. The characteristics of a polymer are that the molecule is either a long chain or a network of repeating units. Plastics are one kind of polymer. It is defined as an organic polymer. It can be moulded into any required shape with the help of pressure or heat or both heat and pressure. The liquid form of plastic is called as resin and it contains carbon as a central element. Oxygen, nitrogen and chlorine are linked to the carbon atoms to form the molecules. The main raw material for making plastics is resin. The different types of resin are acrylic resin, polyethylene resin and amino

resin. These resins are produced by different types of polymerization process. Catalysts, binders, dyes and lubricants are added with the resin to form the plastics.

4.1.2 Polymerization Process

A polymer is made up of linking thousands of monomer and thus obtaining large molecule is called polymerization process. It is achieved by one of the two processing techniques. They are.

1. Addition polymerization
2. Condensation polymerization

1. Addition polymerization

In addition polymerization, similar monomers of large numbers are added chemically one by one. These monomers form a long chain molecule. The basic principle which is used in this bonding is Vander wall's force. The polyethylene is produced by addition polymerization.

In addition polymerization process, no catalyst is used. Polymerization takes place by applying energy in the form of pressure and heat. The addition of two or more different monomers is called co-polymerization process.

2. Condensation polymerization

In condensation polymerization, two or more unlike monomers are linked and there is a repetitive elimination of smaller molecules to form a by-product. During this process, by-product such as water or ammoniac is formed. This by-product formation is known as condensation.

The condensation polymerization requires high pressure and it requires hours or days to complete the process.

4.1.3 Materials Used for Processing of Plastics

The properties of polymers are modified by the addition of agents such as 'additives' and 'fillers'.

a) Additives 1.

Plasticizers

To improve the plastic behavior of the polymer, the plasticizers are added. The plasticizers are in the form of liquids with high boiling point. It acts as an internal lubricant for increasing the toughness and flexibility. The main role of a plasticizer is to separate the

macromolecules, thus, decreasing the inter-molecular forces and facilitating the relative movement between molecules of the polymer. It means, making the deformation is easier.

Examples

Water, organic solvents, resins

2. Catalyst

Catalysts are usually added to promote faster and complete polymerization. The catalysts are also called 'accelerators' and hardeners.

3. Dyes and pigments

Dyes and pigments are added to impart a desired color to the material.

4. Initiators

The initiators are used to initiate the reaction. i.e. it allows to begin polymerization. They stabilize the end reaction of the molecular chains.

Example: H_2O_2 is a common initiator

4.Modifiers

It is used to improve the mechanical properties of plastics such as strength, damping capacity, toughness, ductility, plasticity etc.

6. Lubricants

It is used to reduce friction during processing, to prevent parts from sticking to mould walls, to prevent polymer films from sticking to each other.

Examples: Oils, soaps and waxes.

7. Flame retardants

The flame retardants are added to the plastics to enhance the non-inflammability of the plastics.

Examples: Compounds of chlorine, bromine and phosphorous

8. Solvents

It is useful for dissolving certain fillers or plasticizers and help to allow the processing in the fluid state.

Example: Alcohol

9. **Elastomers**

It is added to the plastics to enhance their elastic properties.

10. **Stabilizers**

It is added to the plastics to retard the degradation of polymers.

11. Fillers

It is used to economize the quantity of polymer required and to vary the properties to some extent. The fillers are used to improve the strength and stability of the plastics. The type of fillers used in plastics is mica, cloth fiber. The mica and asbestos are used to improve the heat resistance capacity of the plastics.

4.1.4 Properties of Plastics

The plastics possess various properties which help the end users to move for lightweight materials. The properties are listed below

- (i) Elongation
- (ii) Heat resistance
- (iii) Insensitive to tension cracks
- (iv) High rigidity
- (v) Surface hardness
- (vi) High viscosity
- (vii) Maximum usage temperature
- (viii) Short term maximum usage temperature
- (ix) Density
- (x) Ignition temperature
- (xi) Humidity absorption
- (xii) General chemical resistance

4.2 Types of plastics

All plastics are broadly classified into two main groups. They are

1. Thermosetting Plastics
2. Thermoplastics

4.2.1 Thermosetting Plastics

The plastics which are hardened by heat effecting a non-reversible chemical change are called thermo-setting.

Thermo setting plastics do not soften on reheating and cannot be reworked. Thermo setting molecules are formed by condensation polymerization.

The molecules of such type of plastics have three dimensional network and very strong binding force between molecules. The raw material for thermosetting plastics is in the form of liquid or solid. These types of plastics are polymerized when moulded or formed. It consumes more time for formation. The various types of thermosetting resin are discussed below.

1. Phenol formaldehyde

It is also named as bakelite. It is made by the reaction of phenol with formaldehyde. It is generally produced in dark colour and it has high strength, stability, and rigidity. It can be easily cast or laminated.

Uses: Plugs, knobs, pulleys, bottle caps, tooling and forming dies.

2. Polyester resin

It has low moisture, good electrical resistance and variety of colours. It is used in paper mat, TV parts and car bodies. The main drawback of the polyester is high cost.

3. Melamines

It has excellent electrical and heat resistance. It has good stability and low moisture absorption. The melamines are available under various names of melmac, catlin, melantine and plaskon. It is widely used for moulded parts.

Uses:

Telephone sets, circuit breakers, switch panels and lighting fixtures.

4. Phenol furfural

It has good flowability at low moulding temperatures and sets quickly at correct temperature. The phenol furfural has good resistance to moisture and electricity.

Examples:

Brake linings, electrical parts and instrument cabinets.

Uses:

It is used as a binder in resinoid abrasive wheels, laminating varnishes and adhesives.

5. Epoxy resins:

The most popular variety of epoxy resins is Araldite. It has good chemical and electrical resistances. It is mostly available in the form of liquid. They also have good resistance to wear and impact. But they are quite expensive.

Uses:

Tools and dies, jigs and fixtures, housings for electrical parts and enamels.

6. Silicones:

Silicones have high resistance to high temperature upto 260°C and possess excellent dielectric strength at high temperatures. In liquid form, they are used as water repellants. They can be compressed and reinforced.

Uses:

It is used in coatings, laminates, foam products and induction heating apparatus.

In rubber form it is used in gaskets for providing high heat resistance.

7. Urea formaldehyde (Amino resin)

It is obtained by the condensation of urea and aqueous formaldehyde. It cannot be cast. But, it can withstand temperature up to 77°C only. It is widely used as an adhesive and binding material

Uses:

It is used in toilet seats, table ware, buttons, clock cases, electric switches and plugs.

8. Alkyds

It is also known as oil-modified polyesters. Alkyds are used in synthetic enamels and lacquers. It is used in solid form where high electrical and heat resistances are required.

Example:

Automobile ignition parts

9. Polyurethanes

It is mainly used for cushions in transportation seats for insulation and electronic equipment as a packing material.

4.2.2 Thermoplastics

The thermoplastics have separate long and large size molecules arranged side by side. It does not have any cross linking in their molecular structure.

Some of the thermo plastic structure is amorphous in nature other than that all are crystalline structure in nature. It is formed by addition polymerization process. When thermo plastics are heated, it becomes very soft and rehardens on cooling. During heating, the linear bonding links between molecules break up and molecules are separated. Relinking takes place on cooling and retains their hardness. It is easily remoulded or extruded to any shape. These plastics do not have a definite melting temperature. The various thermo plastics are discussed below. It is classified into:

1. Cellulose derivatives
2. Synthetic resins

1. Cellulose Derivatives

i) Cellulose nitrate:

It is obtained by treating the cellulose with a mixture of nitric and sulphuric acid. It has high toughness, good resistance to moisture and highly inflammable.

Uses:

Spectacle frames, toilet articles, pen bodies and table tennis balls

(ii) Cellulose acetate:

It is obtained by treating the cellulose with acetic acid. It can be injected and compressed in the mould for obtaining better stability and high mechanical strength. It is lighter than cellulose and tendency to absorb moisture.

Uses:

Photographic films, buttons, radio panels, toys and extruded sheets, tubes and rods *iii) Ethyl*

cellulose:

The ethyl cellulose is the lightest of all cellulose derivatives. It has good electrical properties, chemical resistance, surface hardness and strength.

Uses:

Jigs, fixtures, forming dies, hose nozzles and moulded articles.

iv) Cellulose acetate-butyrate:

It is obtained by treating cellulose with acetic and butyric acid. It has good stability against light and heat and moisture absorption tendency. It can also be injection moulded and extruded.

Uses:

Radio cabinets, pipes and tubing, steering wheels, insulating tapes, handles and coatings. *v)*

Cellophane

It is available in extruded form. It has attractive appearance and good resistance to moisture, fire and solvents.

Uses:

Curtains, drapers wrapping and packaging.

vi) Cellulose propionate:

It has low tendency for moisture absorption and can easily be moulded. The cellulose propionate can withstand temperature upto 93°C.

Uses:

Fountain – pens, telephones and flash light cases. **2.**

Synthetic Resins

- i) ***Polyethylenes:*** it has very high resistance to acids, alkalizes and solvents can be made flexible, tough

and good insulators. It has low water absorption. The polyethylenes are softened at 93°C.

Uses:

Fabrics, trays, pipes and tubing chemical containers and corrosion resistant coatings.

- ii) ***Polystyrenes:***

It has dimensional stabilities and strain resistance. It is easily mouldable and has tendency to crack under load. The polystyrenes are easily jointed by cementing. It can be produced in any form and colours.

Uses:

Battery boxes, radio parts, tableware, toys and high frequency insulation parts.

- iii) ***Acrylic resins:***

It has high transparency tendency. It can be made in any colour with dielectric properties, resistance to moisture, good strength and excellent light transmitting power. It can also be cast injection moulded, extruded and stretch formed into sheets.

Uses:

Tubes, plates, coatings, and adhesives, laminates, display cases, lenses, valves and helmets.

- iv) ***Vinyles:***

Its trade name is PVC. Vinyl plastics are made in the form of flexible or rigid. It has good electrical and weather resistance. The vinyls are water resistant and produced in various colours.

Uses:

Tarpalin, water roofing, raincoats, tubes and insulation.

v) ***Polytetra fluoroethylene:***

Its trade name is Teflon. It has maximum chemical resistance, can withstand temperatures upto 288°C, and cannot be dissolved in any solvent. It has high electrical resistance, low friction and very low adhesion to other substances. It is available in forms such as rods, sheets and tubes.

Uses:

Gaskets, greaseless bearing, electrical insulators and chemical containers.

vi) ***Polyamide:***

It is popularly known by its trade name Nylon. It has high strength, toughness and elasticity. It can be moulded and extruded into rods. The powder metallurgy methods can also be used for this type of plastics. It is a good insulator and has good wear resistance.

Uses:

Yarn for cloth, bearings and coupling, gears, wire insulation and combs.

vii) ***Methyl methacrylate:***

Its trade name is Lucite and plexiglass. It can be formed easily at temperatures around 120°C. It is marked by its clear colour and high light transmission capability.

Uses:

Aircraft parts, transparent bowls, contact lenses and various surgical instruments.

4.2.3 Difference between Thermoplastics and Thermosetting Plastics

S. No	Thermoplastics	Thermosetting plastics
1.	It is softened by heating.	It cannot be softened by this process.
2.	Structure is made of linear chain molecules.	Structure is made of cross linked molecules.

3.	It is produced by addition polymerization process.	It is produced by condensation polymerization process.
4.	It can be reproduced by heating and cooling.	It cannot be reproduced.
4.	The temperature increases with increase in plasticity.	Plasticity is table at high temperatures.
6.	It can be remoulded to any shape	It cannot be remoulded.
7.	It is softer and less strong.	It is harder and strong.
8.	Scrap can be reused.	Scrap cannot be reused.

4.3 Processing of Plastics

- The processing of plastics involves operations similar to those used to form and shape the metals.
- Plastics can be moulded, cast, formed, machined, joined and processed into different shapes with ease and in few operations only.
- As the plastics melt at relatively low temperatures, they are easy to handle and require less energy to process.
- The properties of plastic components are largely affected by the method of manufacture and by the processing parameters hence it is necessary to control these conditions. · Generally plastics are shipped to manufacturing plants as pellets (granules) or powder and they are melted just before the shaping process (for thermo-plastics).
- Plastics are also available as rod, plate, sheet, tubes, etc. which may be formed into a different products.

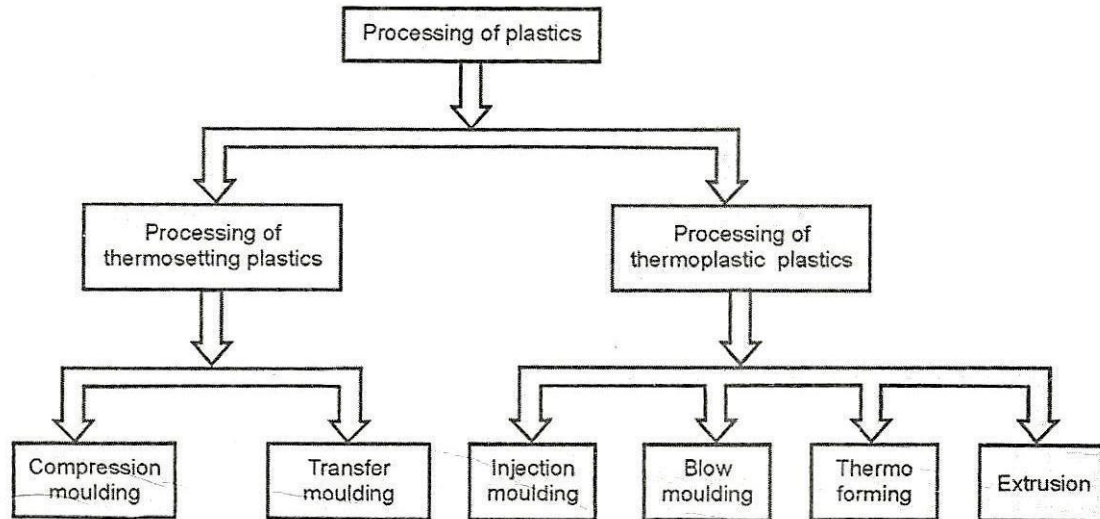

The processing of plastics can be grouped as follows (Refer figure.5.1).

Figure 4.1 Classification of Processing of Plastics

4.4 Processing of Thermosetting Plastics

For processing thermosetting plastics following processes are most commonly used:

Compression moulding

Transfer moulding

4.4.1 Compression Moulding

Compression moulding is mainly used for moulding thermosetting materials.

In this moulding method, a material is generally in powder or pre-form shape and it is loaded directly into the hot die cavity.

A measured amount of plastic powder or a viscous mixture of liquid resin and filler material is placed in the lower female cavity which is continuously heated by either steam or electricity.

The upper half of the die compresses the material which melts and fills the die cavity.

This combined effect of pressure and temperature caused the plastic to flow into the mould cavity.

After compression the component solidifies (polymerises), the upper half of the die opens and the component is removed with the help of ejector pins. Refer figure 5.2.

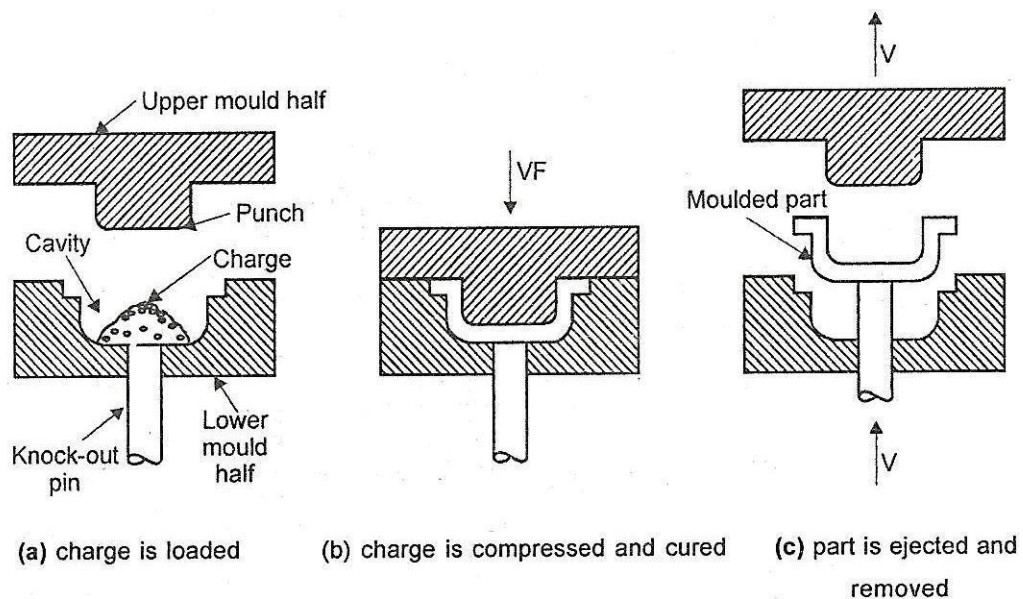

Figure 4.2 Compression Moulding

- Pressure used in the process varies from 0.5 MPa to 50 MPa depending upon the size and material of the component.
- Temperature during the process is from 125°C to 250°C.

The curing time depends upon the material, geometry and thickness of the components.

- Generally the curing time is between 0.5 minutes to 5 minutes.

Following are the four primary factors in a successful compression moulding process.

- Quantity of material

- Heating time and technique
- Force applied to the mould
- Cooling time and technique

Materials that can be processed by compression moulding are phenolics, melamine, urea-formaldehyde, epoxies, urethanes, elastomers, etc.

In compression moulding, the mould structures are of three types

- i) Positive type ii) Semi positive type iii) Flash type

Positive type compression moulding is used for high density parts of composite sheet moulding components, bulk moulding compounds or impact thermosetting materials.

Semi-positive type compression moulding is used for closer tolerance work or when design involves changes in thickness.

Flash type compression moulding is used for shallow parts but results in higher material losses.

Advantages of Compression Moulding

- The moulds used in the process are simple and less expensive. Also they require low maintenance.
- Low residual stresses in the moulded parts.
- Initial set-up cost is low.
- Time required for set-up is low.
- This process is capable of producing large size parts of complicated shapes.
- Good surface finish is obtained by this process.
- Wastage of material is relatively low.

Disadvantages of Compression Moulding

- Cycle time of the process is long.
- This method is having low production rate.

Applications of Compression Moulding

- Compression moulding is used for making flatwares, gears, buttons, buckles, knobs, handles, dishes, container taps and fittings.
- Also used for moulding of electrical and electronic components, washing machine agitators and housings.

4.4.2 Transfer Moulding

- Transfer moulding is used for the processing of thermosetting plastics.
- Transfer moulding is also called as gate moulding.
- This method is an advanced method of compression moulding.
- This is the process of forming articles in a closed mould, where the fluid plastic material is conveyed into the mould cavity under pressure from outside of the mould.
- The material is generally in a preheated form and placed in a heated transfer pot. Refer Figure 5.3.
- When the material is sufficiently softened, the plunger forces the fluid plastic through the sprue into the closed mould, where the final cure takes place.
- Curing time for transfer moulding is generally less than compression moulding.
- An intensity of pressure Varies from 20 MPa to 100 MPa.
Once the plastic component has been cured, the plunger moves up and the component is ejected from the lower portion of the mould cavity with the help of ejector pins. This process is used for producing complicated components having varying wall thicknesses with high accuracy and economical rates.
- Transfer moulding is closely related to compression moulding because it is utilized on the same types of polymers.

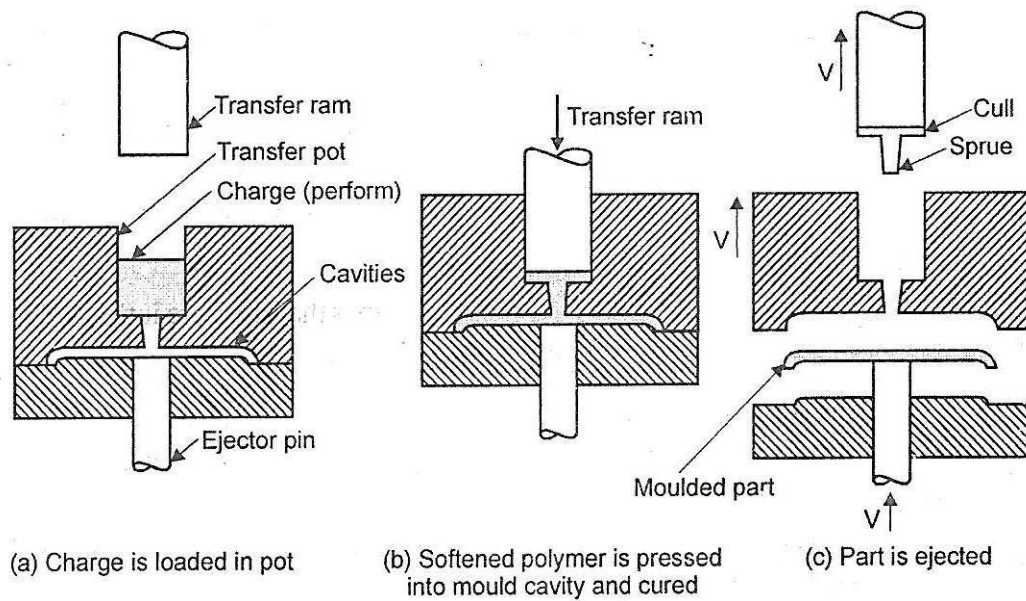

Figure 4.3 Transfer Moulding Advantages of Transfer Moulding

- One of the main advantages of transfer moulding over compression moulding is that, different inserts, such as metal prongs, semiconductor chips, dry composite fibers, ceramics, etc. can be placed in the mould cavity before the polymer is injected into the cavity.
- Product consistency better than compression moulding, hence more intricate parts with high accuracy can be produced.
- Speed of Production is higher than compression moulding.
- Maintenance cost is lower than injection moulding.

Limitations of Transfer Moulding

- The main limitation of the process is that, initial cost of the mould is high.
- In this process wastage of material is more.

Applications of transfer Moulding

- This process is mostly used for manufacturing of integrated circuit packaging and electronic components with moulded terminals, pins, studs, connectors, etc.

4.5 Processing of Thermoplastic Plastics

- There are so many forms of raw materials for processing of plastics into final product.
- The commonly used forms are pellets, sheet, powder, rod, tubing, etc.
- Generally liquid plastics are used in the fabrication of reinforced-plastic parts.
- Thermoplastics can be processed to their final size and shape with the help of following processes:
 1. Injection moulding (plunger and screw type)
 2. Blow moulding
 3. Thermoforming
 4. Extrusion
 4. Rotational moulding

4.5.1. Injection Moulding

Working principle

The injection moulding is used to achieve high speed moulding of thermoplastics. The working principle of this process is that the molten thermoplastic is injected into a mould under high pressure. For achieving high pressure, the plunger system is used.

Operation

The moulding material is loaded into a hopper from which it is transferred to a heating section by a feeding device where the temperature is raised to from 150°C to 370°C. The material melts and is forced by an injection ram or by plunger through a nozzle and sprue in a closed mould which forms the part. There are two types of injection moulding and it is given below.

4.5.1.1 Ram or plunger type injection moulding

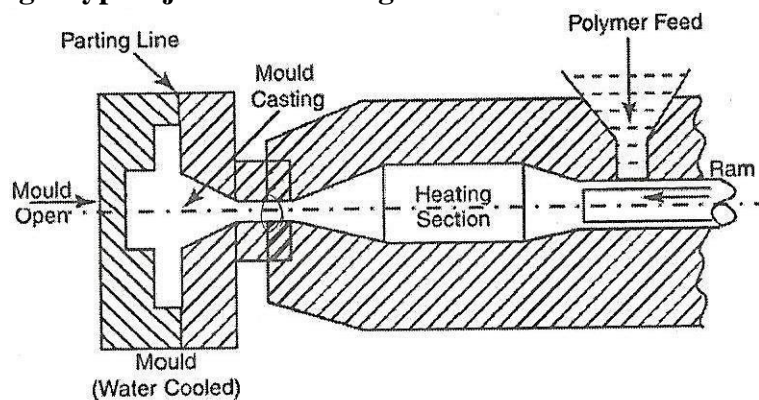

Figure 4.4 Ram or plunger type injection moulding machine The ram and plunger type injection moulding has two units.

1. Injection unit, and
2. Clamping unit.

So, it may be split in order to eject the finished component.

Initially, the polymer is filled in a hopper. Then, it goes to the heating section where the polymer is melted and the pressure is increased. The heated material is injected by the ram under pressure. So, the heated material is forced to fill in the mould cavity through the nozzle to get the required shape of the plastics. Here, the mould is water-cooled type.

4.5.1.2 Screw Type Injection Moulding

In this type also, there are two units to split and eject the finished component such as

1. Injection unit, and
2. Clamping unit.

The injection unit has hopper, screw, and heating section. In clamping section, it has mould. In a screw type moulding machine, the pellets are initially fed into the hopper. The resins are pushed along with the heated reciprocating screw. The screw is moved forward to force the plastic material into the mould. The screw itself is moving backwards and allowing the accumulation of enough material to fill the mould. The rotation of the screw provides the plasticizing action by shearing the frictional effects. The axial motion of the screw provides the filling action. The jet moulding process is used to find the problems occurred in injection moulding process. The reaction moulding is the recent development in injection moulding. In reaction moulding, the low viscosity monomers are used in the mould. A chemical reaction takes place between resins at low temperature and a polymer is created.

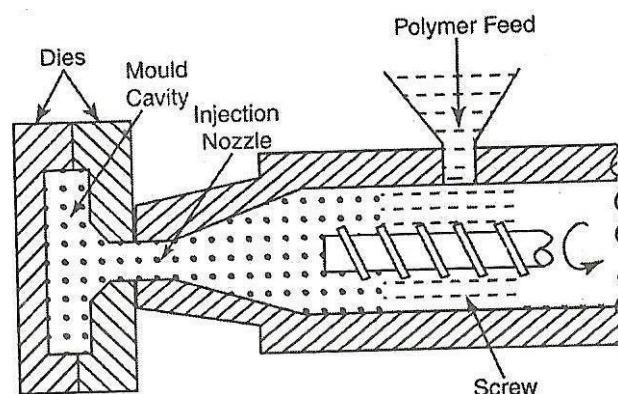

Figure 4.5 Screw Type Injection Moulding machine

In jet moulding, the plastic is preheated about 93°C in the cylinder surrounding the nozzle. The reaction moulding is suitable for the production of polyurethane moulding. The injection capacity of injection moulding machines ranges from 12,000mm³ to 2.2 x 10⁶mm³.

Advantages of injection moulding

1. High production capacity and less material losses are possible.
2. The cost is low and it needs less finishing operation.
3. It is used for making complex threads and thin walled parts.
4. Accuracy becomes $\pm 0.025\text{mm}$.
5. Wide range of shapes can be moulded.

Applications

1. It is used in making parts of complex threads.
2. Intricate shapes such as thin walled parts can be produced.
3. Typical parts such as cups, containers, tool handles, toys, handles, toys, knobs and plumbing fittings can be produced.
4. Electrical and communication components such as telephone receivers can be produced.

Limitation

1. Equipment of cylinder and die should be non-corrosive.
2. The reliable temperature controls are essential.

4.5.2 Blow Moulding

It is a moulding process in which air pressure is used to inflate soft plastic into a mould cavity. It is used to make hollow, seamless parts with thin walls like bottles, containers, etc. from thermoplastic polymers. Blow moulding is performed in two steps:

- i. Fabrication of a starting tube of molten plastic which is called as parison.
- ii. Inflation of the tube to the required final shape.

The forming of parison is carried out either by extrusion or by injection moulding. According to the forming of parison the blow moulding process can be classified as follows:

- a) Extrusion blow moulding
- b) Injection blow moulding

4.5.2.1 Extrusion blow moulding

Blow moulding consists of extrusion of the heated tubular plastic piece called as Parison which is transferred to the two piece mould, Refer Figure 5.6.

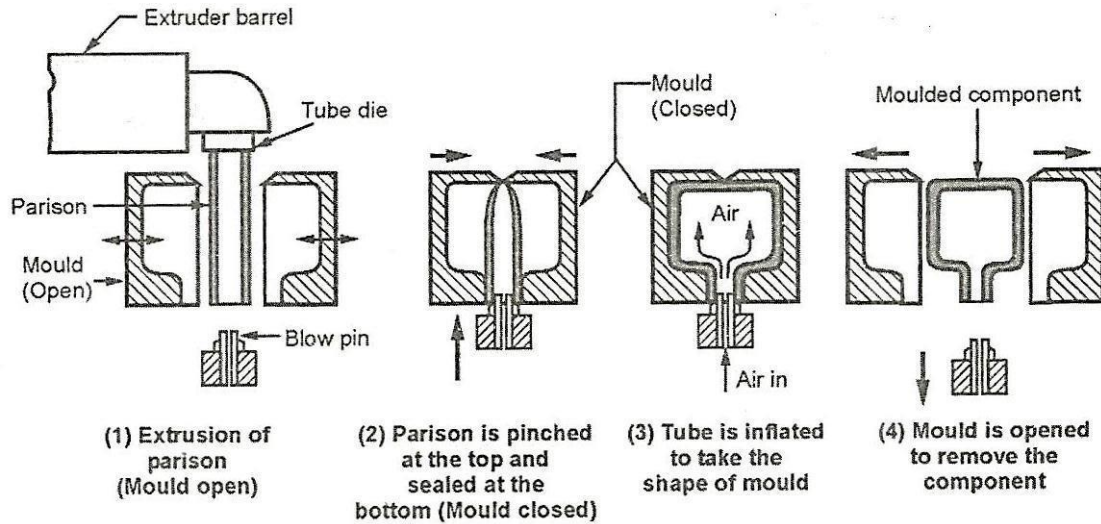

Figure 5.6. Extrusion blow moulding

The parison is gripped between two-piece mould and its bottom end is sealed.

Then, air is injected into the parison to force the plastic against the walls of the water-cooled could.

The pressure air is about 400 to 800 kPa.

As the formed components cool, the mould is opened and the part is removed.

This operation is similar to that used for forming bottles in glass industry.

Polyethylene, polypropylene and cellulose acetate are some of the plastics that can be formed by blow moulding.

4.5.2.2 Injection blow moulding

The working principle of injection blow moulding is similar to extrusion blow moulding.

The only difference is that, in the injection blow moulding the starting parison is injection moulded rather than extruded. Refer Figure 5.7.

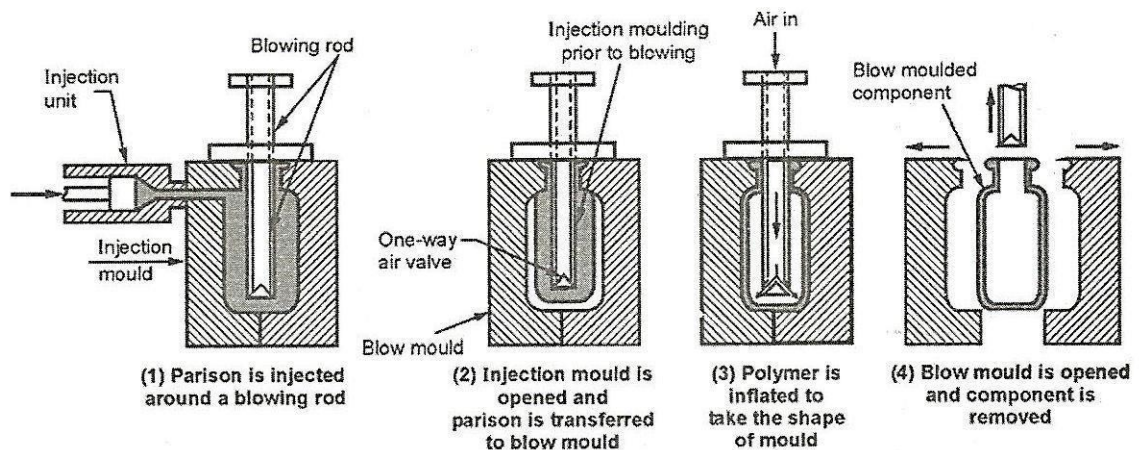

Figure 5.7 Injection Blow Moulding

The main limitation of the injection blow moulding is that, the rate of production is low as compared to extrusion blow moulding.

Due to this limitation, this method of blow moulding is rarely used.

Advantages of blow moulding

Initial cost of mould is low.

Tool flexibility i.e. moulds can accommodate interchangeable neck finishes and body sections.

- Production flexibility i.e. neck inner diameters can be easily controlled to varying requirements. Bottle weights are adjustable.
- There is no restriction of container shape i.e. bottles can be long and flat or have handles.

Applications of blow moulding

- Blow moulding process is mainly used for making cosmetic packaging, food and water bottles, pipes, floats, toys, doll bodies and many other articles.

It is also used for making hollow containers, automobile fuel tanks, boat fenders, heater ducts and hollow industrial parts like drum.

4.5.3 Thermoforming

It is a series of processes for forming thermoplastic sheet or film over a mould with the application of heat and pressure. It is used in packaging of consumer products and to fabricate large parts like bathtubs, internal door liners, etc. It consists of two main steps viz. heating and forming. Heating is carried out by radiant electric heaters, located on one or both sides of the starting plastic sheet. Time of heating depends on the type of polymer, its thickness and colour.

The methods by which forming is carried out are as follows:

- Vacuum forming ○

Pressure forming

4.5.3.1 Vacuum forming

It employs a clamp to grip the plastic sheet having thickness of about 0.125 to 3.2 mm, around its circumference. Refer Figure 5.8 (a).

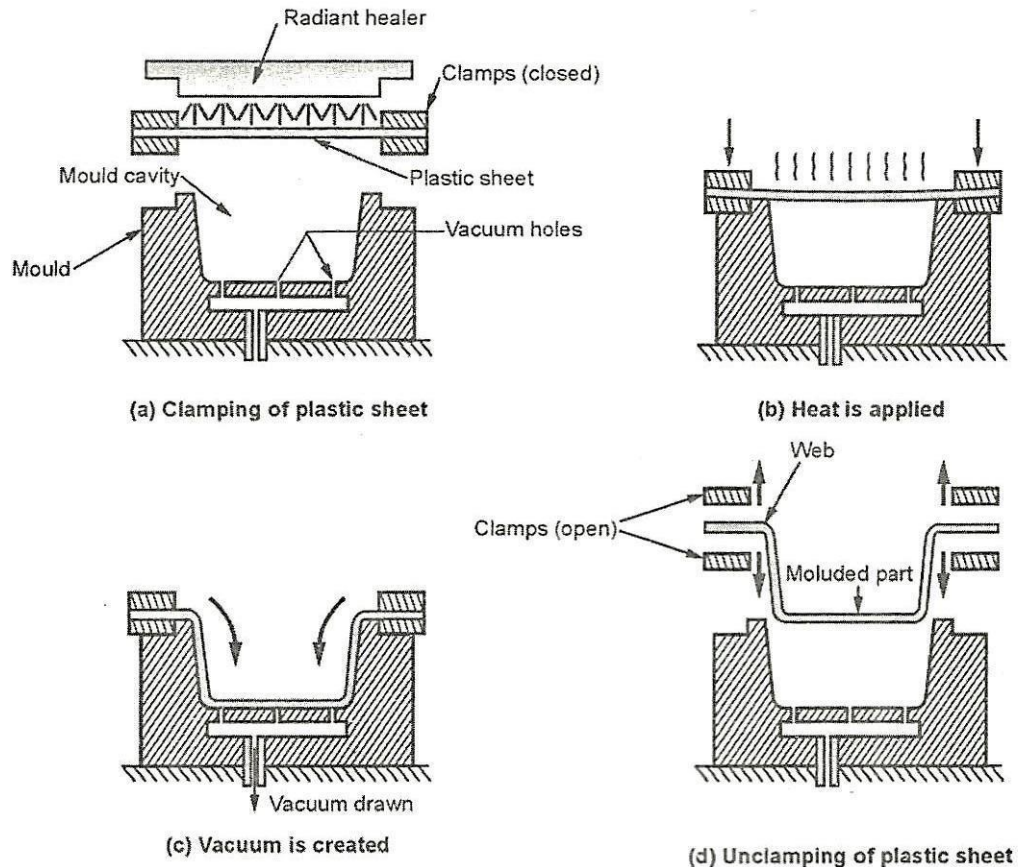

Figure 4.8 Vacuum forming

- A heater is used to bring the polymer to a temperature of about 55°C to 90°C , until it begins to sag.
- Through the small holes in the die, vacuum is applied and the sagging plastic sheet is thus pulled tightly against the mould acquiring the mould shape.

As the mould is cooler, the polymer is chilled and stiffened by die contact.

- Figure 5.8 (b) shows that instead of vacuum sometimes hot air is used to drive the plastic sheet into the female mould cavity.

4.5.3.2 Pressure forming

- It involves positive pressure (no vacuum) to force the heated plastic into the mould cavity. It is also called as blow forming.
- The main advantage of pressure forming over vacuum forming is that, higher pressures can be developed on the component.
- The process sequenced is similar to vacuum forming, the difference being that the sheet is pressurised from above into the mould cavity.

Vent holes are provided in the mould to exhaust the trapped air. The forming portion of the sequence is shown in Figure 5.9.

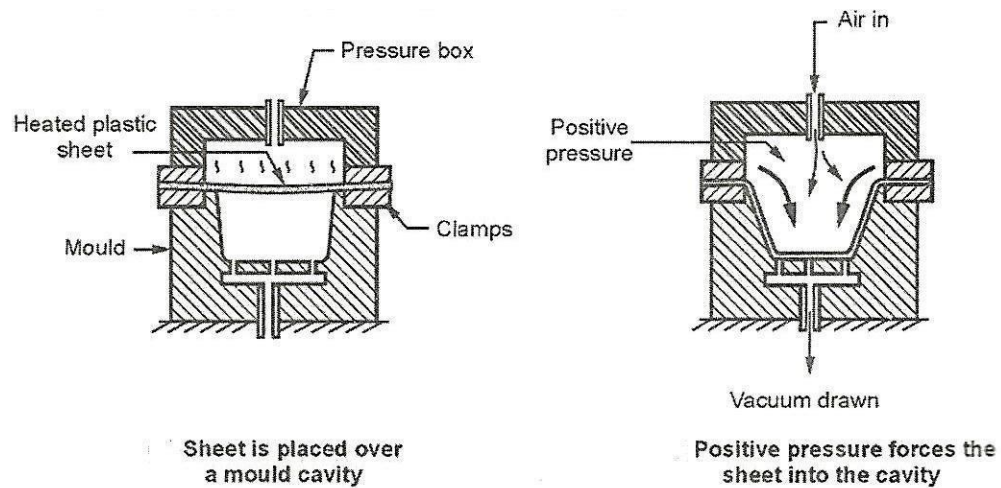

Figure 4.9 Pressure Thermoforming Advantages of thermoforming

- Initial cost of mould is low.
- Time required for set-up is low.
- Production cost is low.
- During the process less thermal stresses are produced.
- Intricate shapes are easily formed.
- The holes in the mould (to pull a vacuum) are generally less than 0.5 mm hence it will not leave any mark on the formed components.
- Generally moulds are made of aluminium because high strength is not required.
- Cost of tooling is low.

Disadvantages/Limitations of Thermoforming

Components with openings or holes cannot be produced by this process.

It is a drawing and stretching operation hence the material should exhibit high uniform elongation, otherwise it will neck and fail.

Applications of Thermoforming

Thermoforming is used for producing small jelly containers used in restaurants, luggage bags, refrigerator inner panels and containers for packaging.

Also used for forming of panels for shower stalls and advertising signs.

4.5.4 Extrusion

Extrusion process is a continuous process in which the hot plastisized material is forced through the die opening of required shape.

- Raw material in the form of thermoplastic pellets, granules or powder is fed through the hopper into a heating cylinder or extruder.
- The extruder is equipped with a screw that blends and conveys the material into a heated die. Refer figure 5.10.

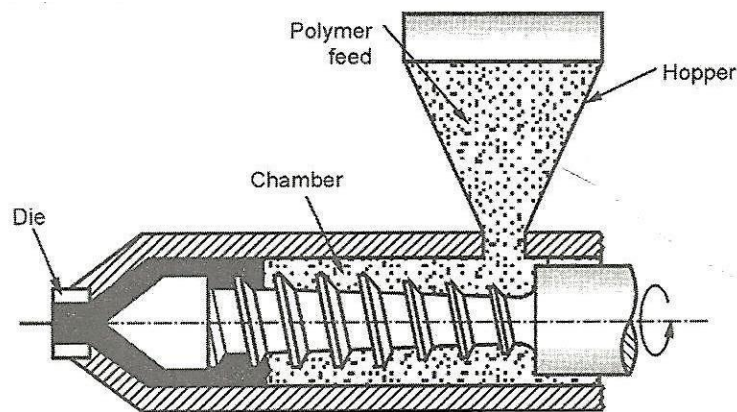

Figure 4.10.Extrusion

- The internal friction due to mechanical action of the screw, along with the heaters around the extruder, heats the material and liquefies it.

The screw have three different sections which are as follows: ○ Feed section which conveys the material from hopper into the central region of extruder.

- Transition or melting section where the heat generated from the shearing of the plastic causes melting to begin.
- Pumping section where additional melting and shearing occurs.

In the heating chamber the material becomes a thick viscous mass where it is forced through the die.

When it leaves the die, it is cooled by air or water or by contact with chilled surface and fully hardens.

To minimise product shrinkage and distortion, control of the rate and uniformity of cooling are important factors.

Extruded component is then coiled or cut into the required lengths.

To colour the plastics, dry colour may be added to screw extruder.

Application of Extrusion

- The extrusion moulding process is used for producing solid rods, pipes or tubes of U, J, Y or other sections.
- Also used for extrusion of candy canes, chewing gums, drinking straws, plumbing pipes, door insulation seals, optical fibers, plastic coated wires, cables, window frames, sheets, strips for electrical applications, etc.

4.5.4.1 Extrusion of Film

- Thermoplastic films are produced by a number of processes, one of them important process is extrusion.
- Film refers to thickness below 0.5mm and they are used for packaging applications like product wrapping material, grocery bags, garbage bags, etc.

A widely used method of making thin polyethylene film for packaging is film blowing.

It is a complex process which combines the principle of extrusion and blowing to produce an thin film Refer figure 5.11.

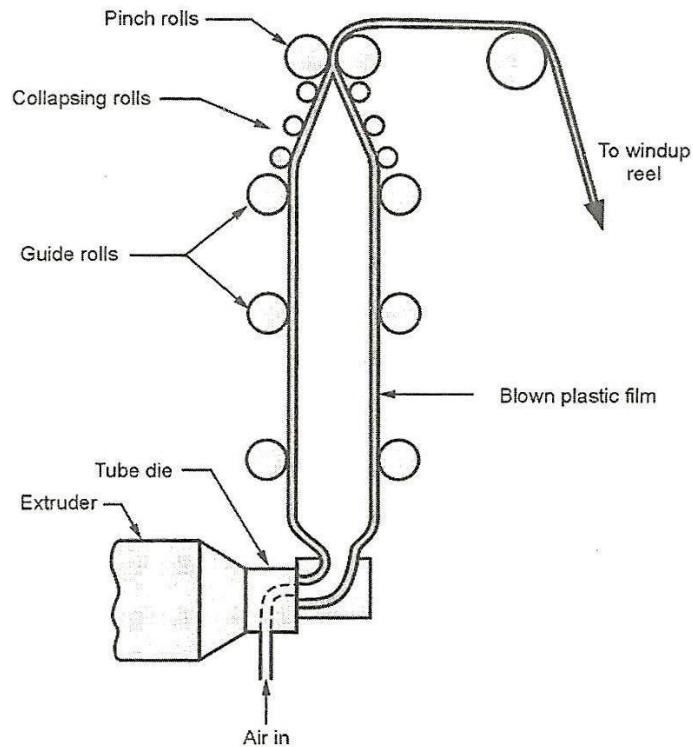

Figure 4.11 Extrusion of Film

- The process starts with the extrusion of a tube which is immediately drawn upward in molten condition and simultaneously expanded in size by blowing air into it through the die mandrel.
- Air pressure in the bubble must be kept constant to maintain uniform thickness and tube diameter.
- Guide rolls and collapsing rolls are used to restrain the blown tube and direct it into the pinch rolls.
- The air contained in the tube is squeezed by pinch rolls and the tube moves forward after it has cooled. Thus the flat tube (film) is then collected into a windup reel.

4.5.4.2 Extrusion of sheet

The term sheet refers to stock with a thickness between 0.5mm to 12.5mm. They are used for products like flat window glazing, stock for thermoforming, etc.

Sheet Forming

- Rubber and some of the thermoplastic sheets are formed by the **Calendering process**.

- In this process the plastic compound composed of resin, plasticizer, filler and colour pigments is heated and passed through the roller.
- The working principle of calendering process is almost similar to rolling process i.e. the material is compressed between rolls and emerges as sheet.
- The main difference between rolling and calendering is that, in calendering there is appreciable thickening after the material has reached minimum thickness at the roll gap and the pre-calendered material is not in the sheet form. Refer figure 5.12.

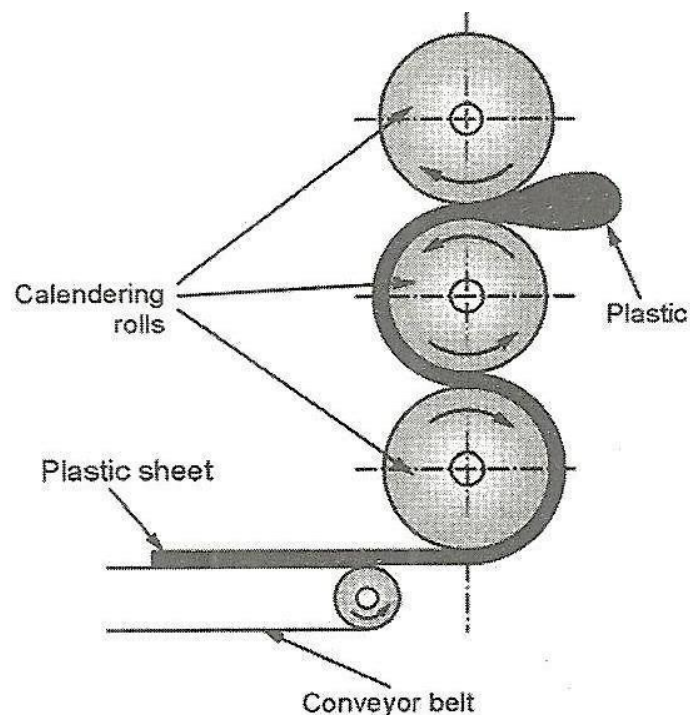

Figure 4.12. Calendering process

The thickness of the produced sheet depends on the spacing between the rollers.

- During the process, the first roll gap serves as a feeder, the second as a metering device and the third one sets the gauge of the gradually cooling plastic which is then would on a coiler.
- Calendering is high production process and mostly suitable for flexible P.V.C.

Applications of Calendering

- Vinyl, polyethylene, cellulose acetate films, vinyl floor tiles are the products of calendering.
- It is also used for production of rainwear, shower curtains, tapes, trays, ATM cards, laminations and transparent film used for packaging.

4.5.5 Rotational Moulding

Working principle

The rotational moulding process is used to make thin walled hollow parts. In this method, a measured quantity of polymer powder is placed in a thin-walled metal mould. The mould is closed and it is rotated about two mutually perpendicular axes as it is heated.

This rotation will cause the powder to sinter against the mould walls. After heating and sintering, the mould is cooled while it is still rotating. The cooling of mould is done by using water and air. Then the rotation is stopped when the moulded component is removed.

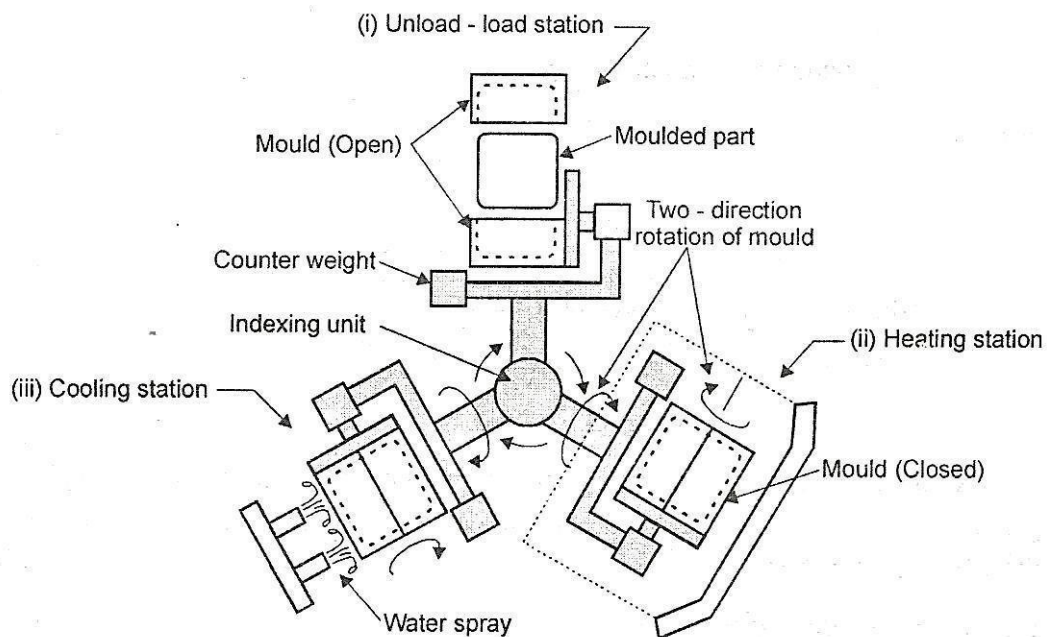

Figure 4.13 Rotational Moulding

In this rotational moulding, thin walled metal mould is made of two pieces and is rotated in perpendicular axis. A measured quantity of powdered plastic material is placed inside the mould. Then, the mould is heated and rotated. This action tumbles the powder against the mould where the heating fuses the powder without melting it. Most thermoplastics and some thermosets can be formed into large hollow parts by rotational moulding. In some parts, chemical agents are added to the powder and cross-linking after the part is formed in the mould by continuous heating.

Rotational moulding can also produce parts with complex hollow shapes with wall thickness of 0.4mm minimum. Large size parts as 1.8m×1.8m×3.6m can also be formed by this process. The surface finish of the mould is same as that of surface finish of walls. The temperature-time relationship during the oven cycle is very important.

Applications:

1. It is used to produce toys in P.V.C.
2. It is used to make large containers of polyethylene.
3. It is used to make petrol tanks for motorcars from polyethylene and nylon.
4. Metallic or plastic inserts are moulded by this process.
5. The buckets, housing, boat hulls and trashcans are made by this process. 6. It is used to produce tanks of various sizes, boat hulls and footballs.

4.6 Bonding of Thermoplastics (Laminating Plastics):

- Bonding of thermoplastics is performed by the application of heat and pressure.
- Laminated plastic consists of sheet of paper, fabric, wood, asbestos, cellulose or other similar materials that are coated with resin.
- Lamination process is based on the principle of layers of sheet like metal foil, paper, etc. bonded together in a stack.
- Starting with the top sheet, a properly adjusted laser, cuts each sheet, one at a time in a particular form.
- The unused portions are discarded (wastage) and individual pieces are bonded together.
- The sheet thickness vary from 0.05 mm to 0.12 mm. Lamination process is classified in two categories:
 - High pressure laminates ○

Low pressure laminates

4.6.1 High pressure laminates

- In this method, layers of fibrous reinforcing materials are joined with thermosetting resin binders by the application of heat and pressure.
 - The pressure generally ranges form 8 MPa to 24 MPa and the temperature is about 150°C.
- It consists of preparing varnish solution from resins by dissolving them in a suitable solvent, followed by coating fibrous sheets with this varnish.

These sheets are then dried, cut to size, heated and pressed between metal plates to form the laminated plates. Refer figure 5.14.

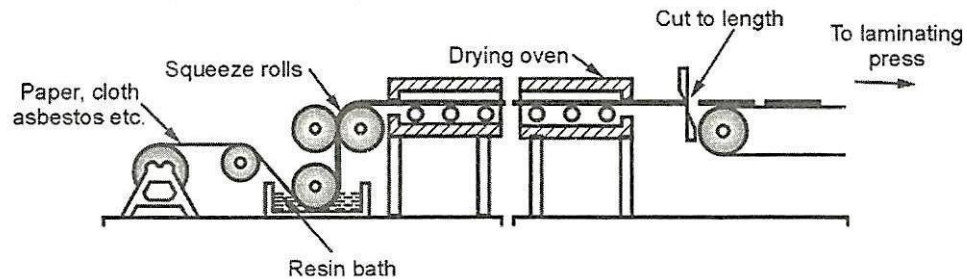

Figure 4.14. Laminating Processes

4.6.2 Low pressure laminates

- In this process, pressure upto 28 MPa are applied.
- Generally thermosetting resins are used in laminating.
- The reinforced materials used are glass, fibre, cotton, nylon, paper and other fibres.
- Commonly used resins are phenolics, polyesters, epoxies and silicones.
- To obtain different colour shades, pigments are added.
- For obtaining better surface finish and better physical properties, fillers like clay, calcium carbonate, asbestos, etc. are added. **Advantages of laminating plastics**
- It is a simple method.
- Cost of the process is low.
- There is no restriction of size.
- The process is flexible.
- Minimum equipments are required during the process.

Applications of laminating plastics

- Laminated plastics are used in electrical and electronic components.
- Heavy cloth laminates are used for gear blanks, cams and other industrial purposes.

- For decorative purpose, laminations are widely used in furniture industry.

4.7 Methods of Bonding of Plastics

Different techniques or methods are used for joining or bonding of plastics. The most of the methods have limitations as per the size or type of plastics which they can joint. The different methods of joining of plastics are as follows:

- | | |
|-------------------------|----------------------|
| a) Mechanical fastening | b) Solvent bonding |
| c) Ultrasonic welding | d) Induction welding |
| e) Vibration welding | f) Hot-plate welding |

a) Mechanical fastening

- It is the simplest way to join the plastic components.
- In this method, the fastening elements like hinge, latch or detent is formed into the components to be joined. It is a low cost method.
- As the joint must survive the strain of assembly, service load and possible repeated use, only the stronger and tougher plastics can be joint.
- Screws, rivets, pins, sheet metal nuts are the commonly used mechanical fasteners.
- They require a plastic which is strong enough to withstand the strain of fastener insertion and subsequent high stress around the fastener.

b) Solvent bonding

- In this technique of bonding, only thermoplastics can be joined by softening them by solvent and then clamping or pressing together.
- Due to this, the plastic molecules intermingle and the components bond together as the solvent evaporates.
- The time of fusion is direct function of solvents evaporation rate and it may be reduced by heating only.
- The pressure to be applied on the component is critical because high pressure may distort the components.

c) Ultrasonic welding

- In this method of joining, two components to be joined are placed together and the ultrasonic pulses are transmitted from a generator to the parts.
- For this purpose resonant vibrating tool called as horn is used which vibrates the component against each other at frequencies around 20,000 Hz.
- Then the parts are heated and fused together.
- It is a fast process and suitable for joining of dissimilar metals also provided that both have same melting temperatures.
- The contact pressure between the two components is critical and it should be just sufficient to cause heating by friction.
- This method is suitable only for thermoplastics except thermosetting resins and teflon.

d) Induction welding

- This method is suitable only for thermoplastics.
 - In this method, two components are pressed together with a metal wire or insert in the joint region and the high frequency magnetic field is switched on around it.
 - This causes the encased metal to be heated up hence melting the plastic and the compression produces good fusion weld.
- In some cases, metal powder may be added to the original plastic moulding but in that case high frequency is needed to affect the weld.
- The cost of this technique is high.

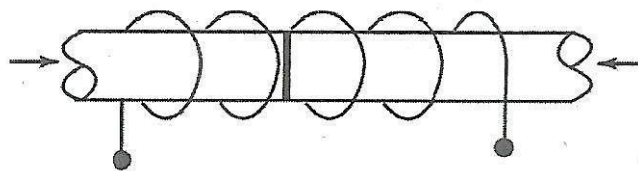

Figure 4.15 Induction welding e) Vibration welding

- This method produces pressure tight joints in circular, rectangular or irregular shaped components made from thermoplastic materials.
- This method is mainly suitable for hollow container type components having the weld joint in a single plane.

During the process, the friction heat is developed by pressing two plastic components and vibrating them at 120 cycles/see in the plane of joint.

After 3-4 second, vibration is stopped at the exact desired relative position of two pieces.

The pressure is maintained briefly while the softened plastic cools. f)

Hot-platen welding

In this method, initially the thermoplastic is softened by contacting it with a heated tool and then pressing together. The material is passed through a hot roller with film or sheet. The sticking between the hot tool and material is prevented by coating the tool with the fluorocarbon. This method is used for welding large, irregularly shaped moulded or extruded parts. A heated platen is kept between the components and the edges to be joined are pressed against it. Now the platen is removed and the components with their edges plasticised as pressed together. After some holding and cooling time, the fixture is opened and the welded assembly is removed.

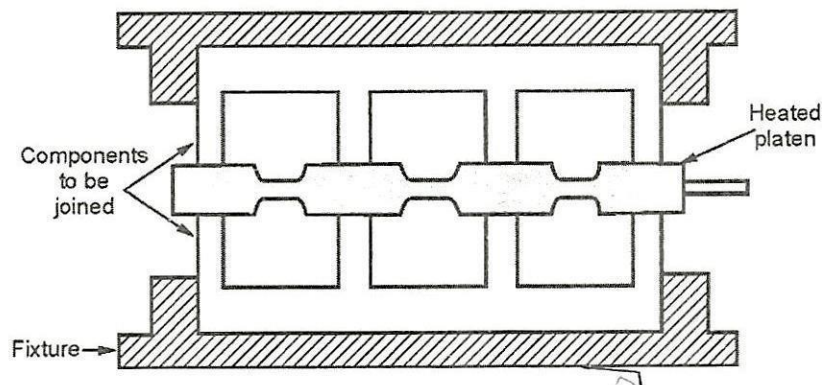

Figure 4.16 Hot-platen welding