



# ROHINI

## COLLEGE OF ENGINEERING & TECHNOLOGY

Approved by AICTE and Affiliated to Anna University (An ISO Certified Institution) | Accredited with A+ Grade by NAAC  
Recognized under Section 2(f) of University Grants Commission, UGC ACT 1956

(AUTONOMOUS)

### THE 555 TIMER

The 555 is a monolithic timing circuit that can produce accurate & highly stable time delays or oscillation. The timer basically operates in one of two modes: either

- (i) Monostable multivibrator or (one - shot)
- (ii) Astable multivibrator or (free

running) The important features of the

555 timer are these:

1. It operates on +5v to +18 v supply voltages
2. It has an adjustable duty cycle
3. Timing is from microseconds to hours
4. It has a current o/p

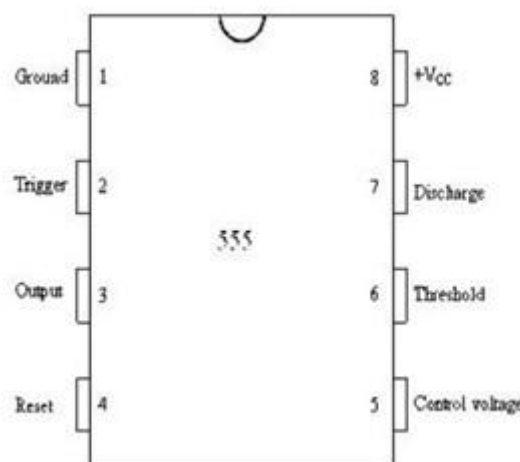

**Figure 5.4.1 Pin configuration of 555 timer**

**Pin description:** Pin configuration of 555 timer is shown in figure 5.4.1.

**Pin 1: Ground:**

All voltages are measured with respect to this terminal.

***Pin 2: Trigger:***

The o/p of the timer depends on the amplitude of the external trigger pulse applied to this pin.

***Pin 3: Output:***

There are 2 ways a load can be connected to the o/p terminal either between pin3 & ground or between pin 3 & supply voltage

(Between Pin 3 & Ground ON load) (Between Pin 3 & + Vcc OFF load)

1. When the input is low:

The load current flows through the load connected between Pin 3 & +Vcc in to the output terminal & is called the sink current.

2. When the output is high:

The current through the load connected between Pin 3 & +Vcc (i.e. ON load) is zero. However the output terminal supplies current to the normally OFF load. This current is called the source current.

***Pin 4: Reset:***

The 555 timer can be reset (disabled) by applying a negative pulse to this pin. When the reset function is not in use, the reset terminal should be connected to +Vcc to avoid any false triggering.

***Pin 5: Control voltage:***

An external voltage applied to this terminal changes the threshold as well as trigger voltage. In other words by connecting a potentiometer between this pin & GND, the pulse width of the output waveform can be varied. When not used, the control pin should be bypassed to ground with 0.01 capacitor to prevent any noise problems.

***Pin 6: Threshold:***

This is the non inverting input terminal of upper comparator which monitors the voltage across the external capacitor.

### ***Pin 7: Discharge:***

This pin is connected internally to the collector of transistor

Q1. When the output is high Q1 is OFF.

When the output is low Q is (saturated) ON.

### ***Pin 8: +Vcc:***

The supply voltage of +5V to +18V is applied to this pin with respect to ground.

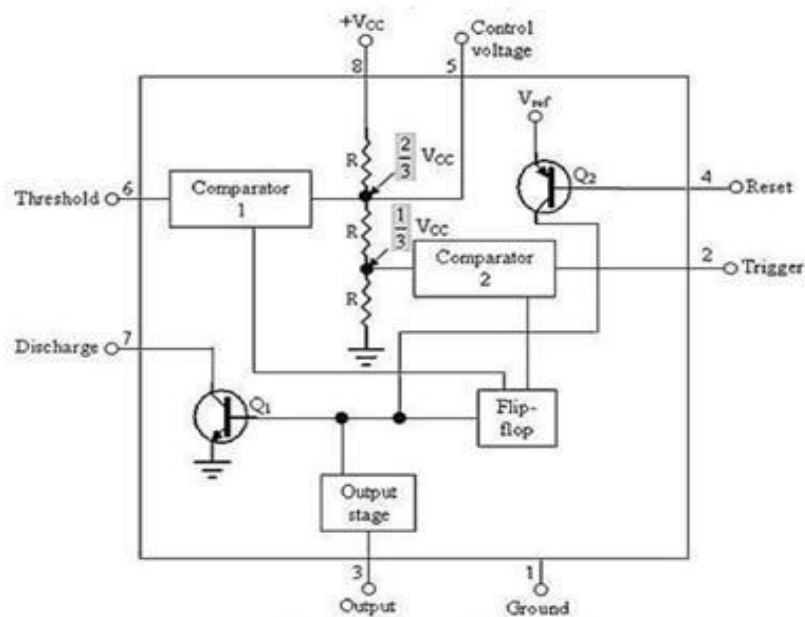

**Figure 5.4.2. Block diagram of IC555 Timer**

From the above figure 5.4.2 three 5k internal resistors act as voltage divider providing bias voltage of  $\frac{2}{3} V_{cc}$  to the upper comparator &  $\frac{1}{3} V_{cc}$  to the lower comparator. It is possible to vary time electronically by applying a modulation voltage to the control voltage input terminal (5).

#### **➤ *In the Stable state:***

The output of the control FF is high. This means that the output is low because of power amplifier which is basically an inverter.  $Q = 1$ ; Output = 0

#### **➤ *At the Negative going trigger pulse:***

The trigger passes through ( $V_{cc}/3$ ) the output of the lower comparator goes high & sets the FF.  $Q = 1$ ;  $Q = 0$

➤ *At the Positive going trigger pulse:*

It passes through  $\frac{2}{3}V_{cc}$ , the output of the upper comparator goes high and resets the

FF.  $Q = 0; Q = 1$

The reset input (pin 4) provides a mechanism to reset the FF in a manner which overrides the effect of any instruction coming to FF from lower comparator.

### MONOSTABLE OPERATION

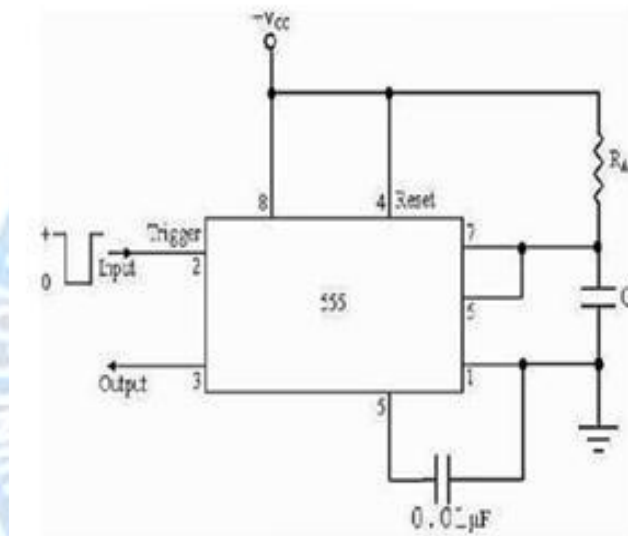

Figure 5.4.3. Monostable Multivibrator using IC 555

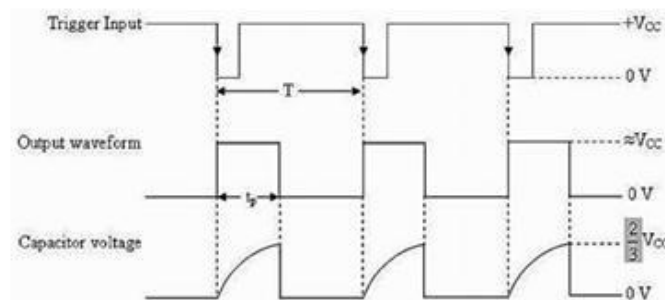

Figure 5.4.4. Waveforms of Monostable multivibrator

Monostable Multivibrator using IC 555 is shown in figure 5.4.3. Initially when the output is low, i.e. the circuit is in a stable state, transistor Q1 is ON & capacitor C

is shorted to ground. The output remains low. During negative going trigger pulse, transistor Q1 is OFF, which releases the short circuit across the external capacitor C & drives the output high. Now the capacitor C starts charging toward Vcc through RA. When the voltage across the capacitor

equals  $2/3 V_{cc}$ , upper comparator switches from low to high. i.e.  $Q = 0$ , the transistor  $Q1 = OFF$  ; the output is high.

Since C is unclamped, voltage across it rises exponentially through R towards Vcc with a time constant RC (figure 5.4.4) as shown in above. After the time period, the upper comparator resets the FF, i.e.  $Q = 1$ ,  $Q1 = ON$ ; the output is low. The voltage across the capacitor is given by

$$V_c = V_{cc} (1 - e^{-t/RC}) \dots\dots\dots$$

(1) Therefore At  $t = T$ ,

$$V_c = 2/3 V_{cc} \quad 2/3 V_{cc} =$$

$$V_{cc}(1 - e^{-T/RC})$$

or

$$T = RC \ln (1/3)$$

Or

$$T = 1.1RC \text{ seconds} \dots\dots\dots (2)$$

If the reset is applied  $Q2 = OFF$ ,  $Q1 = ON$ , timing capacitor C immediately discharged. The output now will be as in figure (d & e). If the reset is released output will still remain low until a negative going trigger pulse is again applied at pin 2.

## APPLICATIONS OF MONOSTABLE MODE OF OPERATION

### (a) FREQUENCY DIVIDER

The 555 timer as a monostable mode. It can be used as a frequency divider by adjusting the length of the timing cycle  $t_p$  with respect to the time period T of the trigger input. To use the monostable multivibrator as a divide by 2 circuit, the timing interval  $t_p$  must be a larger than the time period of the trigger input. [Divide by 2,

$t_p > T$  of the trigger]

By the same concept, to use the monostable multivibrator as a divide by 3 circuit,  $t_p$  must be slightly larger than twice the period of the input trigger signal & so on, [ divide by 3  $t_p > 2T$  of trigger]

### (b) PULSE WIDTH MODULATION

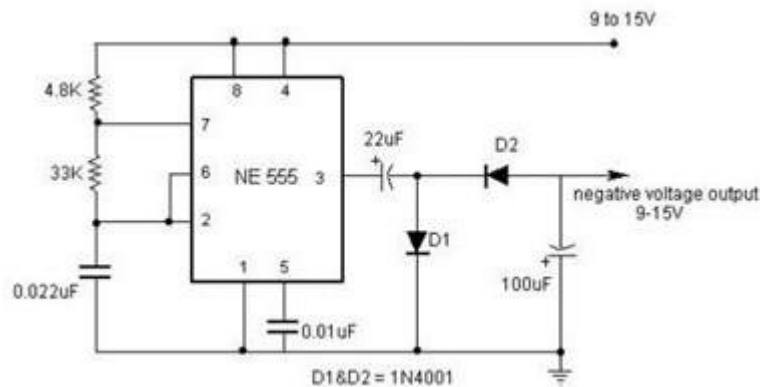

**Figure 5.4.5. Pulse width modulation**

[source: [https://www.brainkart.com/subject/Linear-Integrated-Circuits\\_220/](https://www.brainkart.com/subject/Linear-Integrated-Circuits_220/)]

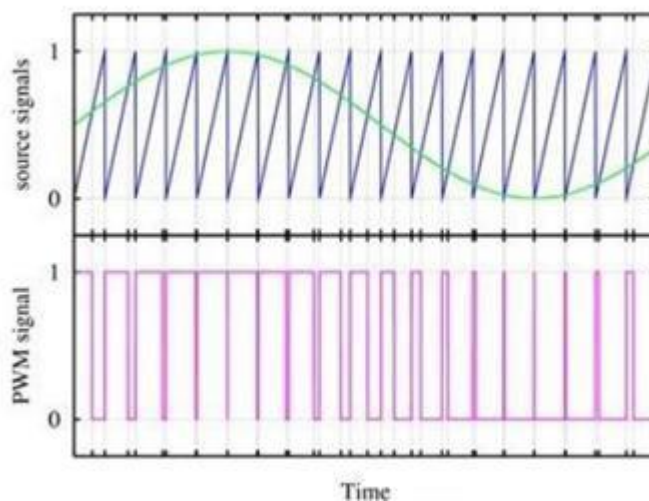

**Figure 5.4.6 Output waveforms**

Pulse width modulation is shown in figure 5.4.5. Pulse width of a carrier wave changes in accordance with the value of an incoming (modulating signal) is known as PWM. It is basically a monostable multivibrator. A modulating signal is fed in to the control voltage (pin 5). Internally, the control voltage is adjusted to  $\frac{2}{3} V_{cc}$ . An externally applied modulating signal changes the control voltage level of upper

comparator. As a result, the required to change the capacitor up to threshold voltage level changes, giving PWM output. Output waveforms are shown in figure 5.4.6.

### (c) PULSE STRETCHER

This application makes use of the fact that the output pulse width (timing interval) of the monostable multivibrator is of longer duration than the negative pulse width of the input trigger. As such, the output pulse width of the monostable multivibrator can be viewed as a stretched version of the narrow input pulse, hence the name “Pulse stretcher”. Pulse Stretcher is shown in figure 5.4.7.

Often, narrow –pulse width signals are not suitable for driving an LED display, mainly because of their very narrow pulse widths. In other words, the LED may be flashing but not be visible to the eye because its on time is infinitesimally small compared to its off time. The 55 pulse stretcher can be used to remedy this problem. The LED will be ON during the timing interval  $t_p = 1.1RA C$  which can be varied by changing the value of RA & C.

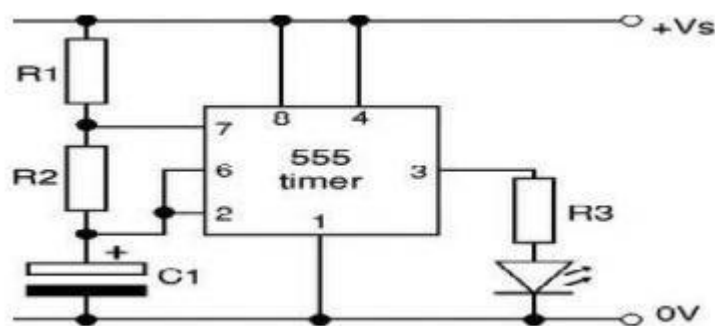
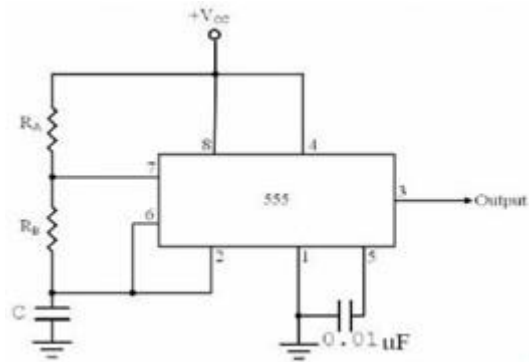

Figure 5.4.7 Pulse Stretcher

### THE 555 TIMER AS AN ASTABLE MULTIVIBRATOR

An Astable multivibrator, often called a free running multivibrator, is a rectangular wave generating circuit. Unlike the monostable multivibrator, this circuit does not require an external trigger to change the state of the output, hence the name free running. However, the time during which the output is either high or low is determined by 2 resistors and capacitors, which are externally connected to the 55 timer.



**Figure 5.4.8 Astable multivibrator using IC555 Timer**

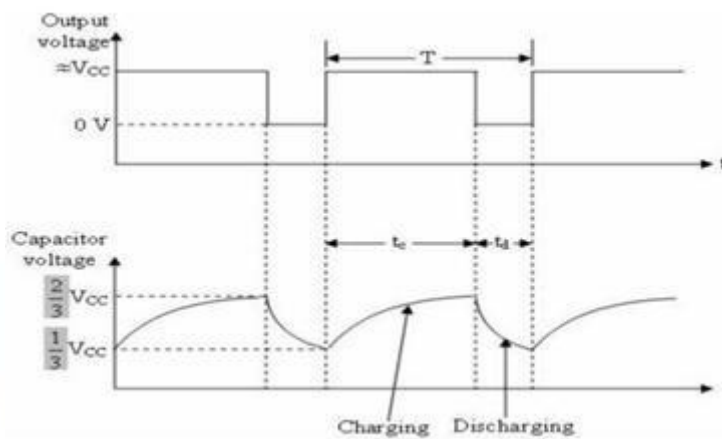

**Figure 5.4.9 waveforms of Astable multivibrator**

The above Figure 5.4.8 and figure 5.4.9 show the 555 timer connected as an astable multivibrator and its model graph

**Initially, when the output is high :**

Capacitor C starts charging toward  $V_{cc}$  through  $R_A$  &  $R_B$ . However, as soon as voltage across the capacitor equals  $2/3 V_{cc}$ . Upper comparator triggers the FF & output switches low.

**When the output becomes Low:**

Capacitor C starts discharging through  $R_B$  and transistor Q1, when the voltage across C equals  $1/3 V_{cc}$ , lower comparator output triggers the FF & the output goes high. Then cycle repeats. The capacitor is periodically charged & discharged between  $2/3 V_{cc}$  &  $1/3 V_{cc}$

respectively. The time during which the capacitor charges from  $1/3 V_{cc}$  to  $2/3 V_{cc}$  equal to the time the output is high & is given by

$$t_c = (R_A + R_B)C \ln 2 \dots \dots \dots (1) \text{ Where } [\ln 2 = 0.69]$$

$$= 0.69 (R_A + R_B) C$$

Where  $R_A$  &  $R_B$  are in ohms. And  $C$  is in farads.

Similarly, the time during which the capacitors discharges from  $2/3 V_{cc}$  to  $1/3 V_{cc}$  is equal to the time, the output is low and is given by,

$$t_c = R_B C \ln 2$$

$$t_d = 0.69 R_B C \dots \dots \dots (2)$$

where  $R_B$  is in ohms and  $C$  is in farads.

Thus the total period of the output waveform is

$$T = t_c + t_d = 0.69 (R_A + 2R_B) C \dots \dots \dots (3)$$

This, in turn, gives the frequency of oscillation as,  $f_0 = 1/T = 1.45 / (R_A + 2R_B)C \dots \dots \dots (4)$

Equation 4 indicates that the frequency  $f_0$  is independent of the supply voltage  $V_{cc}$ . Often the term duty cycle is used in conjunction with the astable multivibrator. The duty cycle is the ratio of the time  $t_c$  during which the output is high to the total time period  $T$ . It is generally expressed as a percentage.

$$\% \text{ duty cycle} = (t_c / T) * 100$$

$$\% \text{ DC} = [(R_A + R_B) / (R_A + 2R_B)] * 100$$

**ASTABLE MULTIVIBRATOR APPLICATIONS:**

**(a) SQUARE WAVE OSCILLATOR**

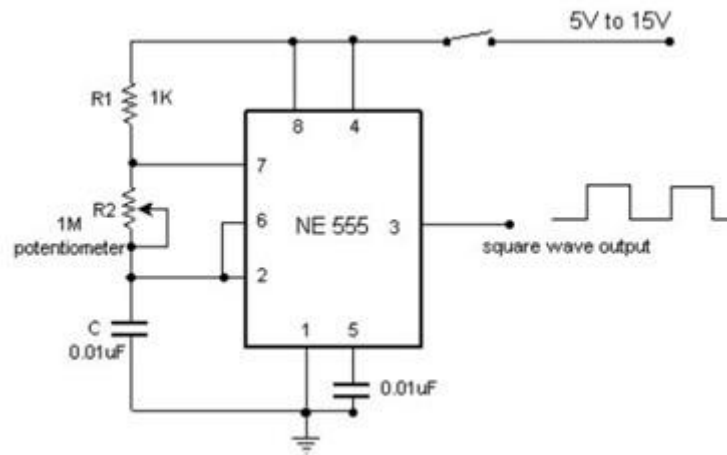

**Figure 5.4.10. Square wave oscillator**

Figure 5.4.10 shows the Square wave oscillator. Without reducing  $R_A = 0$  ohm, the astable multivibrator can be used to produce square wave output. Simply by connecting diode D across Resistor  $R_B$ . The capacitor C charges through  $R_A$  & diode D to approximately  $2/3V_{cc}$  & discharges through  $R_B$  & Q1 until the capacitor voltage equals approximately  $1/3V_{cc}$ , then the cycle repeats. To obtain a square wave output,  $R_A$  must be a combination of a fixed resistor & potentiometer so that the potentiometer can be adjusted for the exact square wave.

**(b) FREE – RUNNING RAMP GENERATOR**

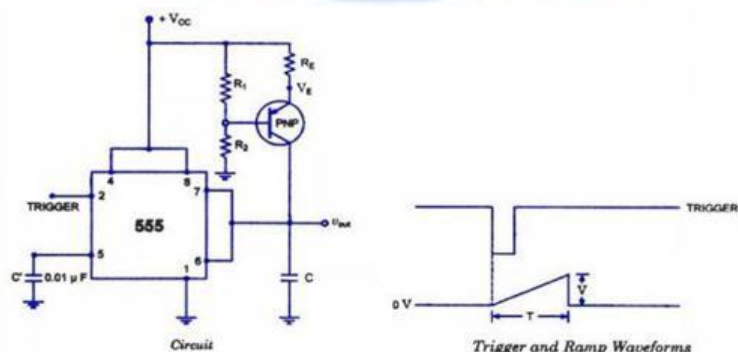

**Figure 5.4.11 Ramp generator using IC 555 Timer and its waveforms**

- Ramp generator using IC 555 Timer and its waveforms is shown in figure 5.4.11. The astable multivibrator can be used as a free – running ramp generator when resistor
- RA & RB is replaced by a current mirror.
- The current mirror starts charging capacitor C toward Vcc at a constant rate.
- When voltage across C equals to  $2/3 V_{cc}$ , upper comparator turns transistor Q1
- When voltage across C equals to  $1/3 V_{cc}$ , lower comparator switches transistor OFF & then capacitor C starts charging up again.
- Thus the charge – discharge cycle keeps repeating.
- The discharging time of the capacitor is relatively negligible compared to its charging time.

The time period of the ramp waveform is equal to the charging time & is approximately is given by,

$$T = V_{cc}C/3I_C$$

$$I_C = (V_{cc} - V_{BE})/R = \text{constant current}$$

Therefore the free – running frequency of ramp generator is

$$f_0 = 3I_C/ V_{cc} C$$