

5.1 REFRIGERATION

Terminologies of Refrigeration

Applications of Refrigeration

Properties of Refrigeration



REFRIGERATION

REFRIGERATION:

It is defined as the process of providing and maintaining a temperature well below that of surrounding atmosphere. In other words, refrigeration is the process of cooling substance

Refrigerators and heat pumps:

If the main purpose of the machine is to cool some object, the machine is named as refrigerator.

If the main purpose of machine is to heat a medium warmer than the surroundings, the machine is termed as heat pump.

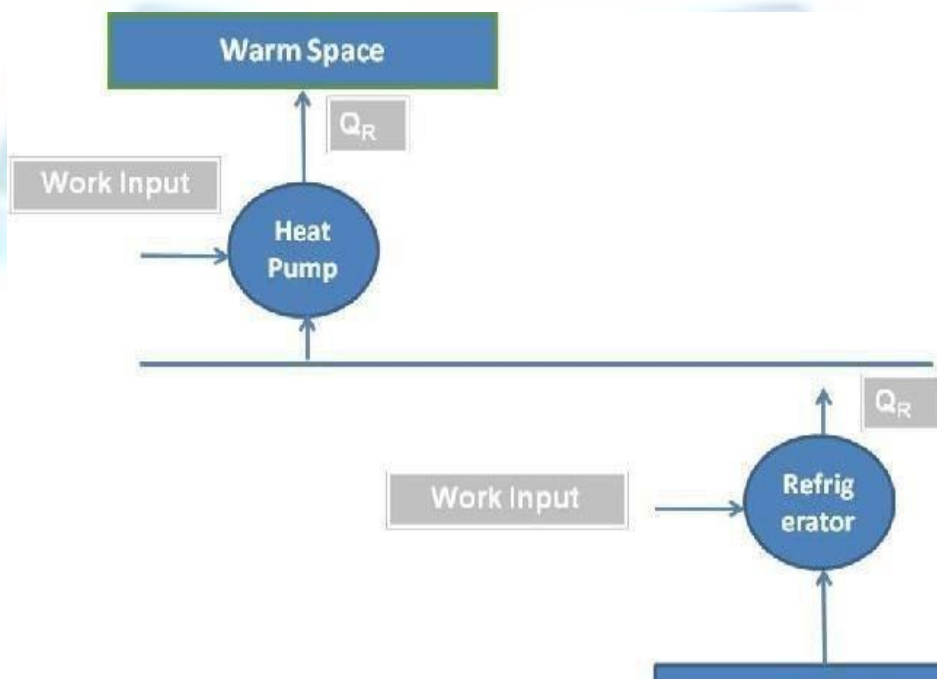

Terminologies of Refrigeration:

Refrigerating Effect (N):

It is defined as the quantity of heat extracted from a cold body or space to be cooled in a given time.

$N = \frac{\text{Heat extracted from the cold space}}{\text{Time taken}}$

Specific Heat of water and ice:

It is the quantity of heat required to raise or lower the temperature of one kg of water (or ice), through one kelvin or (1 °C) in one second.

Specific heat of water, $C_{pw} = 4.19 \text{ kJ/kg K}$

Specific heat of ice, $C_{pice} = 2.1 \text{ kJ/kg K}$.

Capacity of a Refrigeration Unit :

Capacity of a refrigerating machines are expressed by their cooling capacity.

The standard unit used for expressing the capacity of refrigerating machine is ton of refrigeration

One ton of refrigeration is defined as, “the quantity of heat effect) to freeze one ton of water Heat extracted from at 0 °C = latent heat of ice into one ton of ice in a duration of 24 hours at 0 °C”.

Latent heat of ice= 336 kJ/kg i.e., 336 kJ of heat should be extracted one kg of water at 0 °C to convert it into ice.

Co efficient of Performance

It is defined as the ratio of heat extracted in a given time (refrigerating effect) to the work input.

$$\text{Co efficient of performance} = \frac{\text{Heat extracted in evaporator}}{\text{Work Input}}$$

$$\text{Co efficient of performance} = \frac{\text{Refrigerating Effect}}{\text{Work Input}}$$

The COP is always greater than 1 and known as theoretical coefficient of performance.

Applications of Refrigeration:

In chemical industries, for separating and liquefying the gases.

In manufacturing and storing ice

For the preservation of perishable food items in cold

For controlling humidity of air manufacture and heat treatment of. steels.

For chilling the oil to remove wax in oil refineries

For the preservation of tablets and medicines in pharmaceutical industries. For the preservation of blood tissues etc.,

For comfort air conditioning the hospitals, theatres, etc.,

Properties of Refrigeration:

A good refrigerant should have high latent heat of vaporization.

It should have low boiling and low freezing point.

It should be nontoxic and should non corrosiveness

It should be nonflammable and non-explosive.

It should have high thermal conductivity Its should be easy to handle

It should have low specific volume of vapour. should have high co efficient of performance

1. Vapour Compression Refrigeration System.

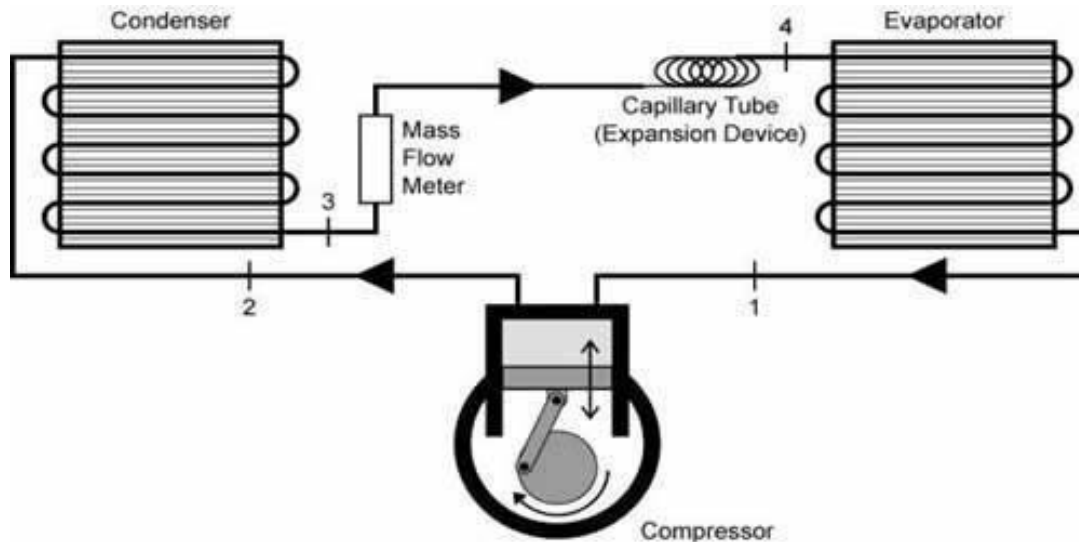

Construction: Vapour compression refrigeration system contains a reciprocating vapour compressor, condenser, capillary tube (expansion device) and evaporator. Reciprocating vapour compressor compresses the incoming low pressure vapour refrigerant into high pressure vapour refrigerant. The function of an expansion device (capillary tube) is to reduce the pressure of high pressure liquid refrigerant into low pressure liquid refrigerant. Condenser and evaporator are the devices in which the phase of the refrigerant occurs.

Working :

1. The low pressure refrigerant vapour coming out of the evaporator flows into the compressor.
2. The compressor is driven by a prime mover.
3. In the compressor the refrigerant vapour is compressed.
4. The high pressure refrigerant vapour from the compressor is then passed through the condenser.
5. The refrigerant gives out the heat it had taken in the evaporator (N)

6. The heat equivalent of work done on it (w) on the compressor.
7. This heat is carried by condenser medium which may be air or water.
8. The high pressure liquid refrigerant then enters the expansion valve.
9. This valve allows the high pressure liquid refrigerant to flow at a controlled rate into the evaporator.
10. While passing through this valve the liquid partially evaporates.
11. Most of the refrigerant is vapourised only in the evaporator, at a low pressure.
12. In the evaporator the liquid refrigerant absorbs its latent heat of vapourisation from the material which is to be cooled.
13. Thus the refrigerating effect (N) is obtained.
14. Then the low pressure refrigerant enters the compressor and the cycle is repeated

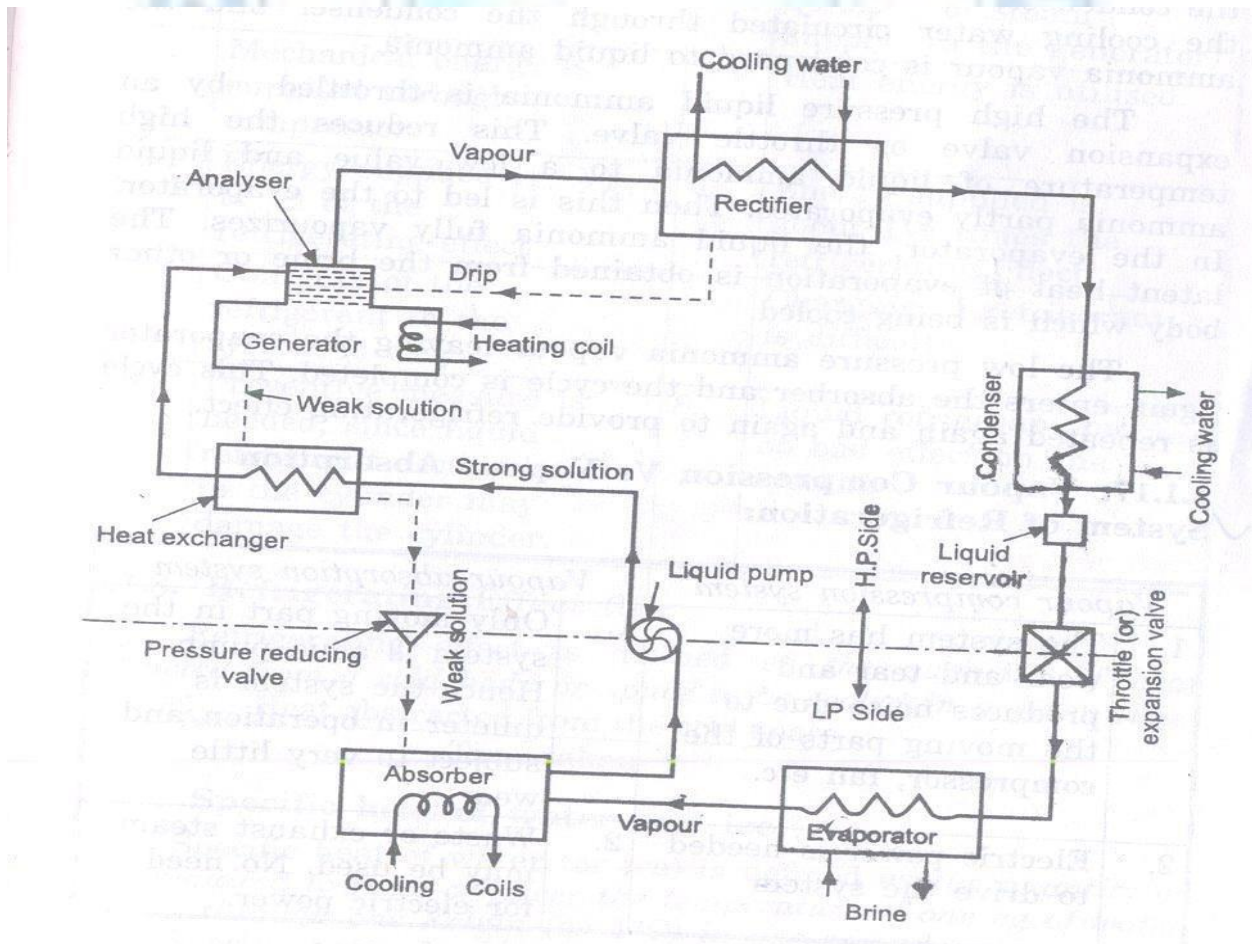

2. Vapour Absorption Refrigeration System.

Construction :

- The vapour absorption system consists of a condenser, an expansion valve and an evaporator.
- They perform the same as they do in vapour compression method.
- In addition to these, this system has an absorber, a heat exchanger, an analyser and a rectifier

Working:

Dry ammonia vapour at low pressure passes in to the absorber from the evaporator.

In the absorber the dry ammonia vapour is dissolved in cold water and strong solution of ammonia is formed. Heat evolved during the absorption of ammonia is removed by circulating cold water through the coils kept in the absorber. The highly concentrated ammonia (known as Aqua Ammonia) is then pumped by a pump to generator through a heat exchanger. In the heat exchanger the strong ammonia solution is heated by the hot weak solution returning from the generator to the absorber. In the generator the warm solution is further heated by steam coils, gas or electricity and the ammonia vapour is driven out of solution. The boiling point of ammonia is less than that of water.

Hence the vapours leaving the generator are mainly of ammonia. The weak ammonia solution is left in the generator is called weak aqua. This weak solution is returned to the absorber through the heat exchanger. Ammonia vapours leaving the generator may contain some water vapour. If this water vapour is allowed to the condenser and expansion valve, it may freeze resulting in choked flow. Analyser and rectifiers are incorporated in the system before condenser.

The ammonia vapour from the generator passes through a series of trays in the analyser and ammonia is separated from water vapour. The separated water vapour returned to generator. Then the ammonia vapour passes through a rectifier. The rectifier resembles a condenser and water vapour still present in ammonia vapour condenses and the condensate is returned to analyser. The virtually pure ammonia vapour then passes through the condenser.

The latent heat of ammonia vapour is rejected to the cooling water circulated through the condenser and the ammonia vapour is condensed to liquid ammonia. The high pressure liquid ammonia is throttled by an expansion valve or throttle valve. This reduces the high temperature of the liquid ammonia to a low value and liquid ammonia partly evaporates. Then this is led to the evaporator.

In the evaporator the liquid fully vaporizes. The latent heat of evaporation is obtained from the brine or other body which is being cooled. The low pressure ammonia vapour leaving the evaporator again enters the absorber and the cycle is completed. This cycle is repeated again to provide the refrigerating effect.

