

MEASUREMENT OF INFILTRATION:

Infiltration in the field can be measured with the help of two types of infiltrometers:

- (a) Single cylindrical or single tube infiltration and (b) concentric double cylindrical or double ring infiltrometers.

Single tube infiltrometer:

It consists of a hollow metal cylinder of 30 cm diameter and 60 cm length with both ends open. The cylinder is driven in the ground such that 10 cm of it projects above the ground. The cylinder is filled with water, such that a head of 7 cm within the infiltrometer is maintained above ground level. Due to infiltration of water, the level in the cylinder will go on decreasing. Water is added to the cylinder, through graduated jar or burette, so as to maintain constant level. The volume of water added over a predetermined time interval gives the infiltration rate for that time interval. The observations are continued till almost uniform infiltration rate is obtained, which may take about 3 to 6 hour, depending upon the type of soil. A plot of in abscissa against rate of water added in mm/h gives the infiltration capacity curve for the area. The major drawback of single tube infiltrometer is that infiltrated water percolates laterally at the bottom of the ring as shown in fig. Hence it does not truly represent the area through which infiltration takes place.

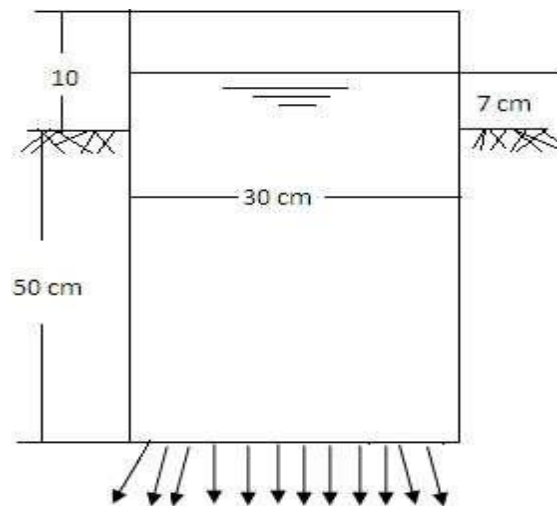

Single tube infiltrometer

Double tube (or double ring) infiltrometer:

The above defect of lateral percolation of water is rectified in the double tube infiltrometer which consists of two concentric hollow rings (or cylinders) driven into the soil uniformly without any tilt and disturbing the soil, to the least depth of 15cm. The diameter of the rings may vary from 25 to 60 cm water is applied in both the inner and outer rings to maintain a constant depth of about 5 cm. Water is replenished after the level falls by about 1 cm. the water depth in the inner and outer rings should be kept the same during the observation period. However, the measurement includes the recording of volume of water added into the inner compartment, to maintain the constant water level and the corresponding elapsed time . as the purpose of the outer ring is to suppress the lateral percolation of water from the inner ring ,the water added to it need not be measured though water is added to it to maintain the same depth as the inner ring. Observations are continued till constant infiltration rate is observed.

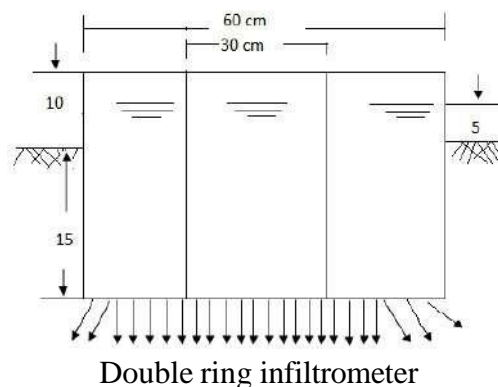

INFILTRATION INDICES:

In the hydrological calculations involving flood it is found convenient use a constant value of infiltration rate for the duration of the storm. The defined average infiltration index . Various infiltration indices give rates of infiltration in different ways to help assessment of the water lost by way of infiltration.

The two important types of indices are the following:

(ii) ϕ Index:

The ϕ index is that portion of average rate of rainfall during any storm which gets lost by the processes of interception, depression storage and infiltration taken together. It can, therefore, be defined as that rate of average rainfall during any storm beyond which the volume of remaining rainfall equals the volume of direct surface runoff. The index can be calculated from a hyetograph (time versus intensity of rainfall graph) of the storm in such a way that the rainfall volume in excess of this rate will equal the volume of the storm runoff . If the rainfall

intensity throughout the storm remains equal to or more than ϕ index then the ϕ index represents basin recharge because ϕ index represents sum total of infiltration, interception and depression storage.

(ii) W-Index: This index gives the average rate of infiltration for that time period of the storm rainfall during which rainfall intensity is greater than W. Thus it can be said to be refinement over ϕ index which apart from infiltration also includes interception and depression storage.

The W index can be obtained from the following equation:

$$W = \frac{P - R - S_a}{t_r}$$

Where

W is average rate of infiltration

P is total storm rainfall corresponding to t

Q is total storm run-off.

t is time during which rainfall intensity is more than W

and S is effective surface retention.

$W = \phi$ average rate of retention

For all practical purposes ϕ index can be taken to represent average rate of infiltration. Since ϕ indices assume average rate of infiltration which in fact is less than initial infiltration rate and more than ultimate infiltration rate their utility is limited to major flood producing storms. Such storms generally occur on wet soil and storms are of such intensity and duration that the infiltration rate could be very nearly taken to be constant for whole storm or majority period of storm. Obviously for short isolated storms ϕ and W indices are not useful.