

8 – Bit Microprocessor (8085): Features and Architecture

Features:

- ❖ The 8085 microprocessor has six general-purpose registers (B, C, D, E, H, and L), which can be paired as BC, DE, and HL for 16-bit operations.
- ❖ The program counter (PC) is a 16-bit register that holds the address of the next instruction and increments after each instruction execution.
- ❖ The stack pointer (SP) is a 16-bit register that keeps track of the top of the stack, used for storing return addresses and temporary data.
- ❖ The instruction register is an 8-bit register that holds the instruction currently being executed.

8085 MICROPROCESSOR ARCHITECTURE

The 8085 microprocessor is an 8-bit processor available as a 40-pin IC package and uses +5 V for power. It can run at a maximum frequency of 3 MHz. Its data bus width is 8-bit and address bus width is 16-bit, thus it can address $2^{16} = 64$ KB of memory. The internal architecture of 8085 is shown in Fig. 2.

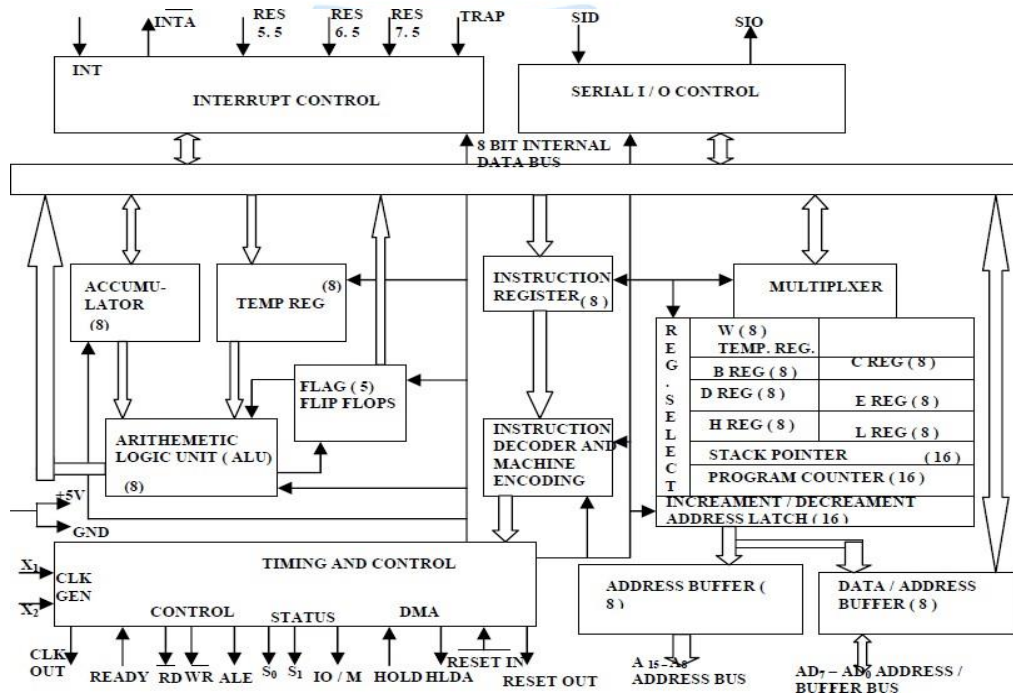

Fig.2 Internal Architecture of 8085

Arithmetic and Logic Unit

The ALU performs the actual numerical and logical operations such as Addition (ADD),

24EC501- Microprocessors, Microcontrollers and Interfacing Techniques

Subtraction (SUB), AND, OR etc. It uses data from memory and from Accumulator to perform operations. The results of the arithmetic and logical operations are stored in the accumulator.

Registers

The 8085 includes six registers, one accumulator and one flag register, as shown in Fig. 3. In addition; it has two 16-bit registers: stack pointer and program counter. They are briefly described as follows.

The 8085 has six general-purpose registers to store 8-bit data; these are identified as B, C, D, E, H and L. They can be combined as register pairs -BC, DE and HL to perform some 16-bit operations. The programmer can use these registers to store or copy data into the register by using data copy instructions.

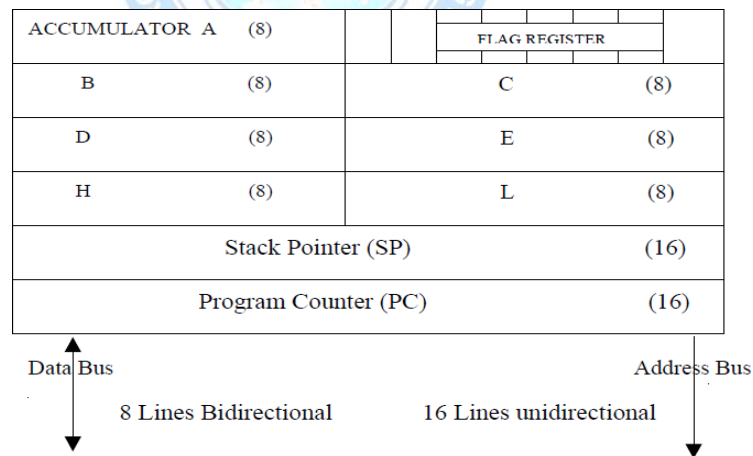

Fig.3 Register organisation

Accumulator

The accumulator is an 8-bit register that is a part of ALU. This register is used to store 8-bit data and to perform arithmetic and logical operations. The result of an operation is stored in the accumulator. The accumulator is also identified as register A.

Flag register

The ALU includes five flip-flops, which are set or reset after an operation according to data condition of the result in the accumulator and other registers. They are called Zero (Z), Carry (CY), Sign (S), Parity (P) and Auxiliary Carry (AC) flags. Their bit positions in the flag register are shown in Fig.4. The micro processor uses these flags to test data conditions.

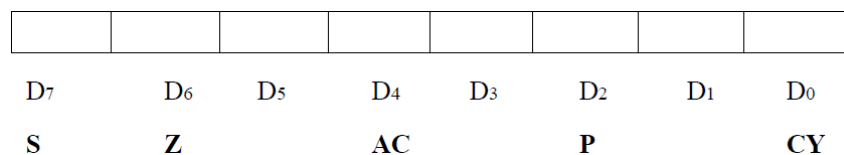

Fig.4Flagregister

For example, after an addition of two numbers, if the result in the accumulator is larger than 8-bit, the flip-flop uses to indicate a carry by setting CY flag to 1. When an arithmetic operation results in zero, Z flag is set to 1. The S flag is just a copy of the bit D7 of the accumulator. A negative number has a 1 in bit D7 and a positive number has a 0 in 2's complement representation. The AC flag is set to 1, when a carry result from bit D3 and passestobitD4. The P flag is set to1, when the result in accumulator contains even number of 1s.

Program Counter (PC)

This 16-bit register deals with sequencing the execution of instructions. This register is a memory pointer. The microprocessor uses this register to sequence the execution of the instructions. The function of the program counter is to point to the memory address from which the next byte is to be fetched. When a byte is being fetched, the program counter is automatically incremented by one to point to the next memory location.

Stack Pointer (SP)

The stack pointer is also a 16-bit register, used as a memory pointer. It points to a memory location in R/W memory, called stack. The beginning of the stack is defined by loading 16- bit address in the stack pointer.

Instruction Register/Decoder

It is an 8-bit register that temporarily stores the current instruction of a program. Latest instruction sent here from memory prior to execution. Decoder then takes instruction and decodes or interprets the instruction. Decoded instruction then passed to next stage.

Control Unit

Generates signals on data bus, address bus and control bus within microprocessor to carry out the instruction, which has been decoded. Typical buses and their timing are described as follows:

- *Data Bus*: Data bus carries data in binary form between microprocessor and other external units such as memory. It is used to transmit data i.e. information, results of arithmetic etc between memory and the microprocessor. Data bus is bidirectional in nature. The data bus width of 8085 microprocessor is 8-bit i.e. 2^8 combination of binary digits and are typically identified as D0 – D7. Thus size of the data bus determines what arithmetic can be done. If only 8-bit wide then largest number is 11111111 (255 in decimal). Therefore, larger numbers have to be broken down into chunks of 255. This slows microprocessor.

24EC501- Microprocessors, Microcontrollers and Interfacing Techniques

- **Address Bus:** The address bus carries addresses and is one way bus from microprocessor to the memory or other devices. 8085 microprocessor contain 16-bit address bus and are generally identified as A0 - A15. The higher order address lines (A8 – A15) are unidirectional and the lower order lines (A0 – A7) are multiplexed (time-shared) with the eight data bits (D0 – D7) and hence, they are bidirectional.
- **Control Bus:** Control bus is various lines which have specific functions for coordinating and controlling microprocessor operations. The control bus carries control signals partly unidirectional and partly bidirectional. The following control and status signals are used by 8085 processor:
 - I. **ALE (output):** Address Latch Enable is a pulse that is provided when an address appears on the AD0 – AD7 lines, after which it becomes 0.
 - II. **\overline{RD} (active low output):** The Read signal indicates that data are being read from the selected I/O or memory device and that they are available on the data bus.
 - III. **\overline{WR} (active low output):** The Write signal indicates that data on the data bus are to be written into a selected memory or I/O location.
 - IV. **$\overline{IO/M}$ (output):**It is a signal that distinguished between a memory operation and an I/O operation. When $\overline{IO/M}=0$ it is a memory operation and $\overline{IO/M}=1$ it is an I/O operation.
 - V. **S1 and S0 (output):** These are status signals used to specify the type of operation being performed; they are listed in Table 1.

Table 1 Status signals and associated operations

S1	S0	States
0	0	Halt
0	1	Write
1	0	Read
1	1	Fetch

The schematic representation of the 8085 bus structure is as shown in Fig.5. The microprocessor performs primarily four operations:

- I. **Memory Read:** Reads data (or instruction) from memory.
- II. **Memory Write:** Writes data (or instruction) in to memory.
- III. **I/O Read:** Accepts data from input device.
- IV. **I/O Write:** Sends data to output device.

The 8085 processor performs these functions using address bus, data bus and control bus as shown in Fig. 5.

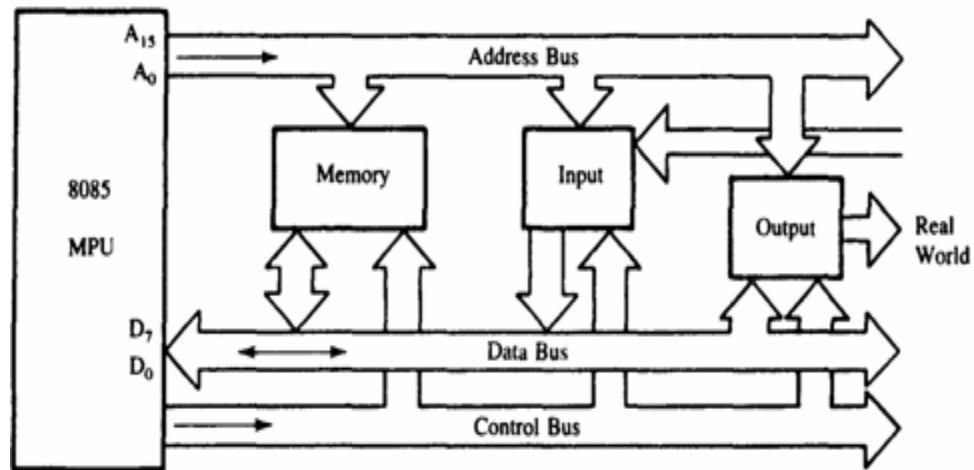

Fig.5 The 8085 bus structure

