

Course Code:	24ME306	Course Title:	Manufacturing Processes
Credits:	4	L-T-P	3-0-2

Course Objectives:

To impart knowledge

- To understand the basic concepts of sand casting technique and special casting technique.
- To understand the principles and equipment used for different welding techniques
- To understand the working principles of bulk deformation of metals.
- To justify the need for High energy rate of special forming and the processing method available for plastics.
- To understand the processing of digital manufacturing.

Teaching-Learning Process:

Suggested strategies that teachers may use to effectively achieve the course outcomes:

1. Chalk and Talk
2. Blended Mode of Learning
3. Experiential Learning
4. NPTEL and Other Videos for theory topics
5. Flipped Class
6. Lab Experiment Videos

UNIT I – Metal Casting Processes	[9 hours]
Introduction to Casting: Overview of casting as a manufacturing process. Pattern and Mold Design: Types of patterns, materials, and allowances. Molding Sands: Properties and testing methods. Melting Furnaces: Types and principles. Casting Techniques: Shell molding, investment casting, pressure die casting, centrifugal casting. Casting Defects: Identification and remedies.	
UNIT II – Metal Forming Process	[9 hours]
Fundamentals of Metal Forming: Hot and cold working principles, Forging: Open, closed, and impression die forging, Rolling: Flat and shape rolling operations. Drawing: Wire and tube drawing processes. Extrusion: Hot and cold extrusion methods.	
UNIT III – Joining and Fastening Processes	[9 hours]
Welding: Physics of welding, types of welding processes, Brazing and Soldering: Principles and applications, Solid-State Joining: Processes like diffusion bonding. Liquid-State Joining: Processes such as fusion welding. Adhesive Bonding: Types and applications.	
UNIT IV – Plastic Moulding	[9 hours]
Types of plastics – Types of Moulding – Injection Moulding, Blow Moulding, Compression Moulding, Transfer Moulding, Rotational Moulding, Extrusion, Thermoforming, Calendaring.	

UNIT V – Advanced Manufacturing Techniques	[9 hours]
Microfabrication Technologies: Silicon growth, photolithography, soft lithography. Wet and Dry Etching Techniques: Introduction and applications. Additive Manufacturing Techniques: Overview of additive manufacturing processes. Stereo- Lithography, Laminated object Manufacturing, Fused Deposition Modelling, Selective laser Sintering, Binder Jet technology.	

Laboratory Component:**[30 hours]**

Any 10 experiments have to be completed from the following list of experiments.

Sl. No	Name of the Experiment
1.	Design and fabricate patterns using various materials.
2.	To Prepare sand molds using green sand and other molding materials & Implement gating systems and risers
3.	To Prepare metal matrix composites using Stir casting Machine
4.	Understand flat rolling mechanics and calculate thickness reduction.
5.	Perform single or multi-stage forging operations, compare grain structure, measure dimensional accuracy
6.	To perform blanking & piercing operation on thin sheet metal using power press machine.
7.	Practice bead and groove welds on mild steel using arc welding.
8.	Perform torch brazing (e.g., copper tubing via capillary action) and electric soldering on electronics. Evaluate joint strength and wetting using pull tests. Compare both processes on metal parts.
9.	Perform wet etching (e.g., TMAH, HF) and RIE dry etching to pattern wafer structures; measure etch depth and sidewall angles
10.	Use SLA printer to fabricate a micro-featured model; post-cure, clean, measure surface finish and dimensional accuracy
11.	Print parts using FDM and SLS; assess layer adhesion, porosity, and suitability for end-use; compare build speed and mechanical behaviour

Course outcomes:

On completion of the course, the student will have the ability to:

CO No.	Course Outcomes	Highest cognitive level
CO1	Apply knowledge of casting processes to solve real-world manufacturing problems.	K3
CO2	Apply knowledge of forming machining processes to solve real-world manufacturing problems.	K3
CO3	Apply appropriate joining techniques (e.g., welding, brazing, adhesive bonding, mechanical fastening) to assemble components in real-world scenarios, using correct procedures and parameters..	K3
CO4	Demonstrate the selection and implementation of appropriate molding processes for given part designs, considering equipment requirements, material suitability, processing conditions, and design constraints	K3
CO5	Demonstrate the design and fabrication of components using microfabrication technologies and additive manufacturing techniques, considering material properties, design constraints, and process parameters.	K3

COs and POs Mapping:

COs	POs											
	1	2	3	4	5	6	7	8	9	10	11	12
CO1	3	2	2	2	-	2	2	-	1	-	-	1
CO2	3	2	2	2	-	2	2	-	-	2	-	1
CO3	3	2	2	2	-	-	-	-	-	-	-	1
CO4	3	2	2	-	-	-	-	-	-	2	-	1
CO5	3	2	2	2	-	2	1	-	1	2	-	1

Level 3- Highly Mapped, Level 2- Moderately Mapped, Level 1- Low Mapped, Level 0- Not Mapped

Scheme of Evaluation:

Component	Type of assessment	Max Marks	Reduced Marks	Total	Final marks
Continuous Internal Examination (CIE) - Theory	CIE – I	100	50	100	25
	CIE – II	100			
	MCQ	20	10		
	Skill Assessment - I	40	40		
	Skill Assessment - II	40			
Continuous Internal Examination (CIE) - Laboratory	Continuous Assessment	75	75	100	25
	Model Lab Exam	25	25		
End Semester Examination (ESE)	Theory Exam	100	35	50	50
	Lab Exam	100	15		
				Total	100

End semester Examination: (QP PATTERN)

- Each unit consists of two 2 marks questions and one 16 marks question (either or)
- All the fifteen questions have to be answered.

Assessment Pattern:

Bloom's Category	Continuous Assessment Tests		Terminal Examination
	1	2	
Remember	20	20	20
Understand	40	40	40
Apply	40	40	40
Analyze	0	0	0
Evaluate	0	0	0
Create	0	0	0

Text Books:

1. Kalpakjian. S, “Manufacturing Engineering and Technology”, Pearson Education India, 4th Edition, 2013
2. P.N.Rao Manufacturing Technology Volume 1 Mc Grawhill Education 5th edition, 2018.

REFERENCES:

1. Roy. A. Lindberg, Processes and materials of manufacture, PHI / Pearson education, 2006.
2. S. Gowri P. Hariharan, A.Suresh Babu, Manufacturing Technology I, Pearson Education, 2008.
3. Paul Degarma E, Black J.T and Ronald A. Kosher, Elighth Edition, Materials and Processes, in Manufacturing, Eight Edition, Prentice – Hall of India, 1997.
4. Hajra Chouldhary S.K and Hajra Choudhury. AK., Elements of workshop Technology, volume I and II, Media promoters and Publishers Private Limited, Mumbai, 1997
5. Sharma, P.C., A Text book of production Technology, S.Chand and Co. Ltd., 2004
6. Lan Gibson, David W. Rosen and Brent Stucker, “Additive Manufacturing Technologies: Rapid Prototyping to Direct Digital Manufacturing”, Springer, 2010.

Web links and Video Lectures (e-Resources):

Metal Casting Processes: <https://archive.nptel.ac.in/courses/112/107/112107083/>

Joining And Fastening Processes : https://onlinecourses.nptel.ac.in/noc21_mm01/preview

Bulk Deformation Processes : https://onlinecourses.nptel.ac.in/noc24_me108/preview

Sheet Metal Forming Processing Of Plastics: https://onlinecourses.nptel.ac.in/noc24_me51/preview
<https://archive.nptel.ac.in/courses/113/106/113106098/>

Digital Manufacturing: <https://archive.nptel.ac.in/courses/112/103/112103306/>

1. Principles of foundry technology, P L Jain, 4th edition, Tata McGrawHill,2006.
(<https://books.google.co.in/books?id=NOotk64Grx0C&printsec=frontcov>)
2. Advanced Welding Processes technology and process control, John Norrish, Wood Head Publishing,2006.(<http://www.elcoweld.com/files/editor/downloads/elmi/AWP1.pdf>)
3. E-Foundry - IIT Bombay - <http://efoundry.iitb.ac.in/Academy/index.jsp>
4. NPTEL - <http://nptel.ac.in/courses/112107145>
5. http://www.astm.org/DIGITAL_LIBRARY/STP/SOURCE_PAGES/STP494.htm

Suggested Skill Activities

1. Analyze real-world casting applications in industries such as automotive, aerospace, and construction. Identify challenges faced and solutions implemented in casting processes.
2. Given a product specification, design the appropriate pattern, mold, and gating system. Select suitable materials and determine necessary allowances.
3. Given an industrial part (e.g., connecting rod or structural beam), recommend a forming method—justify choices, and consider material, shape, and cost.
4. Design a die for wire drawing and extrusion for a specified profile; calculate reduction ratio, drafting angles, and evaluate lubrication needs.
5. Propose a joining method for dissimilar metals (e.g., steel to aluminum) intended for automotive
6. Examine failed joints (weld, braze, adhesive); identify defect type (porosity, voids, insufficient wetting), root cause, and recommend preventative measures, factoring in bonding strength, corrosion resistance, and cost efficacy.
7. Mold a simple part (e.g., cube or comb), optimize temperature, pressure, and cycle time; test and report on dimensional accuracy and surface finish.
8. Produce a hollow bottle/preform, adjust parison thickness and blow pressure; inspect wall uniformity and defect-free finish.
9. Design and fabricate a PDMS microchannel for a biosensor; perform photolithography + soft lithography; test fluid flow and evaluate fabrication accuracy.
10. Compare SLA, FDM, SLS, Binder Jet across criteria (resolution, surface quality, material compatibility, cost); choose best-fit process for dental vs aerospace parts.
11. Design a functional component (e.g., custom bracket), print via SLA or FDM, and test performance; iterate by adjusting print orientation and support design.

1.1 Introduction

- Casting or founding is the process of producing metal or alloy component parts.
- The parts of desired shapes are produced by pouring the molten metal or alloy into a prepared mould and then allowing the metal or alloy to cool and solidify.
- This solidified piece of metal or alloy is called as casting.

1.1.1 Steps involved in making a casting

Following are the steps to be followed while making a sand casting.

1. **Pattern making:** Make the pattern of wood, metal or plastic.
2. **Sand mixing and preparation:** Select a particular sand, test it and prepare the necessary sand mixtures for mould and core making.
3. **Core making:** With the help of pattern prepare the mould and required cores.
Note: Mould is a container having a cavity of the shape to be cast, whereas core is a body which is employed to produce a cavity in the casting and is generally made of sand.
4. **Melting:** Melt the metal or alloy to be cast.
5. **Pouring:** Pour the molten metal or alloy into the mould and remove the casting from the mould after solidification of metal.
6. **Finishing:** Clean and finish the casting.
7. **Testing:** Test and inspect the casting and remove the defects, if any.
8. **Heat treatment:** Relieve the casting stresses by using various heat treatments.
9. **Re-testing:** Again inspect the casting and deliver it.

1.2 Advantages and Application of Metal

Casting Advantages

- Casting is one of the most versatile manufacturing processes.
- It provides the greatest freedom of design in terms of shape, size and quality of product.
- Casting provides uniform directional properties and better vibration damping capacity to the cast components.
- Complex and uneconomical shapes which are difficult to produce by other processes can be easily produced by casting process.
- A product obtained by casting is one piece; hence there is no need of metal joining processes.
- Very heavy and bulky parts which are difficult to get fabricated, may be cast.
- It also produces machinable parts.
- Casting process can be mechanized and generally used for mass production of components.

Applications

A few applications of casting or cast components are given below:

- Transportation vehicles (in automobile engine and tractors)
- Machine tool structures
- Turbine vanes and power generators
- Mill housing
- Pump filter and valve
- Railway crossing and aircraft jet engine blades
- Agricultural parts and sanitary fittings
- Construction, communication and atomic energy applications, etc.

1.3 Sand Casting

Sand casting is used to produce a wide variety of metal components with complex geometries. These parts can vary greatly in size and weight, ranging from a couple ounces to several tons. Some smaller sand cast parts include components as gears, pulleys, crankshafts, connecting rods, and propellers. Larger applications include housing for large equipment and heavy machine bases.

For sand casting, the most common metals are iron, steel, bronze, brass and aluminum. With these alloys, sand casting can produce small parts that weigh less than one pound or large parts the weight several tons.

The process is used to make medium to large parts such as valve bodies, plumbing fixtures, locomotive components and construction machinery. Its versatility also allows sand casting to produced small parts such as buckles, handles, knobs and hinges.

It is a cost effective and efficient process for small lot production, and yet, when using automated equipment, it is an effective manufacturing process for high-volume production.

Sand casting is also common in producing automobile components, such as engine blocks, engine manifolds, cylinder heads, and transmission cases.

The sand casting process involves the use of a furnace, metal, pattern, and sand mould. The metal is melted in the furnace and then ladled and poured into the cavity of the sand mould, which is formed by the pattern. The sand mould separates along a parting line and the solidified casting can be removed.

Key points on advantages and disadvantages of sand casting:

Advantages

- Low cost of mould materials and equipment.

- Large casting dimensions may be obtained.
- Wide variety of metals and alloys (ferrous and non-ferrous) may be cast (including high melting point metals).

Disadvantages

- Rough surface.
- Poor dimensional accuracy.
- High machining tolerances.
- Coarse Grain structure.
- Limited wall thickness: not higher than 0.1”-0.2” (2.5-5 mm).

1.3.1 Steps involved in sand casting process

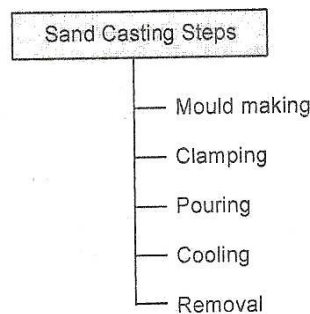

The process cycle for sand casting consists of five main stages, which are explained below.

a) Mould-making

The first step in the sand casting process is to create the mould for the casting. In an expendable mould process, this step must be performed for each casting. A sand mould is formed by packing sand into each half of the mould. The sand is packed around the pattern, which is a replica of the external shape of the casting.

When the pattern is removed, the cavity that will form the casting remains. Any internal features of the casting that cannot be formed by the pattern are formed by separate cores which are made of sand prior to the formation of the mould. Further details on mould-making will be described in the next section.

The mould-making time includes positioning the pattern, packing the sand, and removing the pattern. The mould-making time is affected by the size of the part, the number of cores, and the type of sand mould. If the mould type requires heating or baking time, the mould-making time is substantially increased.

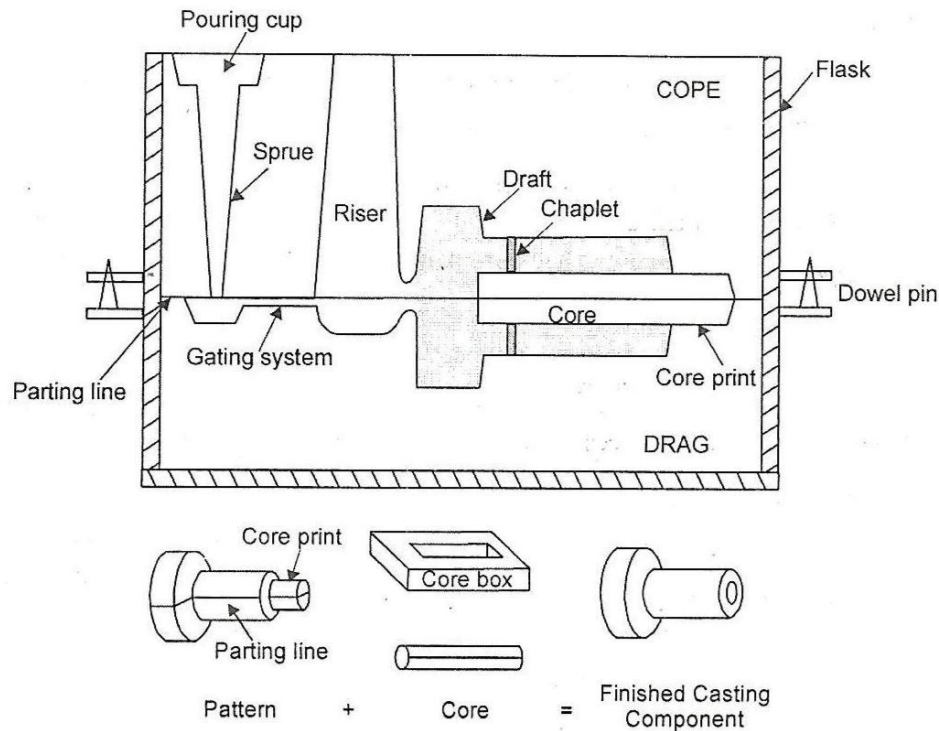

Figure 1.1: Cross section of a typical two-part mould, showing various features

Also, lubrication is often applied to the surfaces of the mould cavity in order to facilitate removal of the casting. The use of a lubricant also improves the flow of the metal and can improve the surface finish of the casting. The lubricant that is used is chosen based upon the sand and molten metal temperature.

b) Clamping

Once the mould has been made, it must be prepared for the molten metal to be poured. The surface of the mould cavity is first lubricated to facilitate the removal of the casting.

Then, the cores are positioned and the mould halves are closed and securely clamped together. It is essential that the mould halves remain securely closed to prevent the loss of any material.

c) Pouring

The molten metal is maintained at a set temperature in a furnace. After the mould has been clamped, the molten metal can be ladled from its holding container in the furnace and poured into the mould.

The pouring can be performed manually or by an automated machine. Enough molten metal must be poured to fill the entire cavity and all channels in the mould. The filling time is very short in order to prevent early solidification of any one part of the metal.

d) Cooling

The molten metal that is poured into the mould will begin to cool and solidify once it enters the cavity. When the entire cavity is filled and the molten metal solidifies, the final shape of the casting is formed.

The mould cannot be opened until the cooling time has elapsed. The desired cooling time can be estimated based upon the wall thickness of the casting and the temperature of the metal. Most of the possible defects that can occur are a result of the solidification process. If some of the molten metal cools too quickly, the part may exhibit shrinkage, cracks, or incomplete sections.

e) Removal

After the predetermined solidification time has passed, the sand mould can simply be broken, and the casting removed. This step, sometimes called shakeout, is typically performed by a vibrating machine that shakes the sand and casting out of the flask. Once removed, the casting will likely have some sand and oxide layers adhered to the surface. Shot blasting is sometimes used to remove any remaining sand, especially from internal surfaces, and reduce the surface roughness.

f) Trimming

During cooling, the material from the channels in the mould solidifies attached to the part. This excess material must be trimmed from the casting either manually via cutting or sawing, or using a trimming press.

The time required to trim the excess material can be estimated from the size of the casting's envelope. A larger casting will require a longer trimming time. The scrap material the results from this trimming is either discarded or reused in the sand casting process. However, the scrap material may need to be reconditioned to the proper chemical composition before it can be combined with non-recycled metal and reused.

1.4 Pattern Making

- A pattern is a mould forming tool in the hands of foundry men.
- A pattern is defined as a model or replica of the object to be cast.
- A pattern exactly resembles the casting to be made except for the various allowances.
- If one object has to be cast, then also pattern is required.
- It is a model or form around which sand is packed to give rise to a cavity called as **mould cavity**, in which molten is poured and the casting is produced.
- The ways in which a pattern differ from a casting are as follows:
 - A pattern is slightly larger than the casting because a pattern carries allowance to compensate for metal shrinkage.

- Also, pattern carries allowances for machining so as to clean and finish the required surfaces.
- Pattern also has the necessary draft for its easy removal from the sand mass.
- It carries additional projections, called as coreprints, to produce seats for the cores.
- A pattern may not have holes and slots which a casting will have. Such holes and slots make a pattern complicated, hence can be drilled in the casting after it has been made.
- The material from which casting and pattern is made, is also different.

1.4.1 Functions of a Pattern

The main functions of a pattern are as follows:

- To prepare a mould cavity of appropriate shape and size for the purpose of making a casting.
- To produce seats for the cores in the mould in which cores can be place, for producing cavity in the casting. Such seats in the mould are called as **core prints**.
- To establish the parting line and parting surfaces in the mould.
- To minimize casting defects.
- To help for positioning of a core before the moulding sand is rammed.
- It should minimize the overall casting cost.

1.5 Pattern Materials

Selection of materials for pattern

The following factors should be considered while selecting proper material for pattern:

- The number of casting to be made; metal patterns are preferred for large quantity of production.
- Degree of accuracy in dimensions and the quality of surface finish required on the casting.
- Method of moulding to be used i.e. hand or machine.
- Type of casting method to be used i.e. sand casting, investment casting, etc.
- Shape, size and complexity of the casting.
- Casting design parameters.
- Type of moulding material to be used.

1.5.1 Materials for Making Patterns

The common materials of which the patters are made are as follows:

- | | | | | |
|---------|----------|------------|------------|--------|
| 1. Wood | 2. Metal | 3. Plastic | 4. Plaster | 5. Wax |
|---------|----------|------------|------------|--------|

1. Wood :

It is the most common material for making patterns for sand casting because of following advantages:

Advantages

- It is cheap and easily available in large quantities.
- It can be easily shaped and machined to different configurations and forms.
- Good surface finish can be easily obtained.
- Due to lightness in weight its manipulation is easy and it can also be repaired easily.

Limitations

- Wooden patterns are weak as compared to metal patterns.
- They cannot withstand rough handling.
- They possess poor wear resistance and hence they are abraded easily by sand action.
- They absorb moisture, hence get warped and change the shape and size.

Applications

- Wooden patterns are mostly used where number of casting to be made is small and the size of pattern is large.
- The common woods used in pattern making are:
(a) White pine (b) Mahogany (c) Maple (d) Cherry (e) Teak

2. Metals

Metal patterns are cast from wooden patterns.

Advantages

- They do not absorb moisture.
- They are stronger and accurate, hence more life as compared to wooden patterns.
- They have greater resistance to abrasion and wear.
- They can withstand rough handling.

Limitations

- As compared to wooden patterns they are more expensive.
- They are heavier than wooden patterns.
- Ferrous material patterns get rusted.
- They cannot be repaired easily.

Applications

- Metal patterns are used where large numbers of castings have to be produced from the same pattern.

- The various metals and alloys employed for making patterns are:
 - (a) Aluminum and its alloys
 - (b) Steel
 - (c) Brass
 - (d) Cast iron
 - (e) White metal

3. Plastic:

Plastic is now a days considered as a pattern material due to their following advantages:

Advantages

- Light weight and high strength.
- Resistance to wear and corrosion.
- Provides good surface finish.
- They are easy to make and less costly also.

Limitations

- Plastic patterns are fragile; hence light sections may need metal reinforcements.
- They may not work well when subjected to conditions of severe shock.

4. Plaster:

Plaster of paris or gypsum cement is used as a patterns material because of following advantages:

Advantages

- Complicated shapes can be cast without any difficulty.
- It can be easily worked with the help of wood working tools.
- It has high compressive strength.
- Unlike metals it expands while solidifying.

Applications

Plaster is used for making small and intricate patterns and core boxes.

5. Wax

Wax is used for specialized applications such as investment casting,

etc. **Advantages**

- They provide good surface finish.
- After being moulded, the wax pattern is not taken out; rather the mould is inverted and heated and the molten wax comes out or gets evaporated, hence there is no chance of the mould cavity getting damaged while removing the pattern.
- Also, the provide high accuracy to the castings.

Applications

Wax patterns are exclusively used in investment casting process.

1.6 Pattern Allowance

A pattern is always made larger than the final casting, because it carries certain allowance due to metallurgical and mechanical reasons. The following allowances are provided on the pattern:

- (a) Shrinkage or contraction allowance
- (b) Machining allowance
- (c) Draft or taper allowance
- (d) Distortion allowance
- (e) Rapping or shake allowance

(a) Shrinkage or constriction allowance

- Almost all the metals used in the casting work shrink or contract during cooling from pouring temperature to room temperature.
- This contraction takes place in three forms i.e.
 - Liquid contraction
 - Solidifying contraction
 - Solid contraction

To compensate liquid and solidifying contraction, gates and risers are provided in the mould, whereas for solid contraction adequate allowance are provided on the pattern. The different metals shrink at different rates because shrinkage is the metal property, hence corresponding allowances are also different. The shrinkage of metal depends on the following factors:

- The metal to be cast
- Pouring temperature of the molten metal
- Dimensions of the casting
- Method of moulding

Shrinkage allowance for different cast metals is given in the following Table 1.1

Table 1.1 Typical Shrinkage Allowances

Materials	Shrinkage Allowance
Cast Iron	10.4 mm/m
Aluminium	17 mm/m
Brass	15.3 mm/m
Steel	20.8 mm/m
Zinc, Lead	25 mm/m

(b) Machining allowance

Machining allowance or finish allowance is the amount of dimension on a casting which is made oversized to provide stock for machining. A casting may require machining all over or on certain specified portions. Such portions or surfaces on the pattern are given adequate allowance in addition to the shrinkage allowance.

The amount of machining allowance depends upon following factors:

- Metal of casting
- Machining method used
- Casting method used
- Shape and size of the casting
- Amount of finish required on the machined portion

Ferrous metal needs more allowance than the non-ferrous metals and similarly, large castings need more allowance than small castings. Machining allowance varies from 1.5mm to 16mm, but 3 mm allowance is more common for small and medium castings.

(c) Draft allowance

Draft allowance or taper allowance is given to all vertical faces of a pattern for their easy removal from sand without damaging the mould. This slight taper inward or outward on the vertical faces is known as draft. It can be expressed either in degrees or in mm/meter. Generally, it is more on internal surfaces as compared to external surfaces. The amount of draft allowance depends on following factors:

- i) Shape and size (height) of the pattern
- ii) Method of moulding
- iii) Material of moulding

This allowance varies from 10mm to 25 mm per meter on external surfaces and 40mm to 65mm per meter on internal surfaces. Fig. 1.2 shows two patterns i.e. one without taper allowance and other with taper allowance. It can be seen that, it is easy to withdraw the pattern having taper allowance out of the mould without damaging the mould cavity.

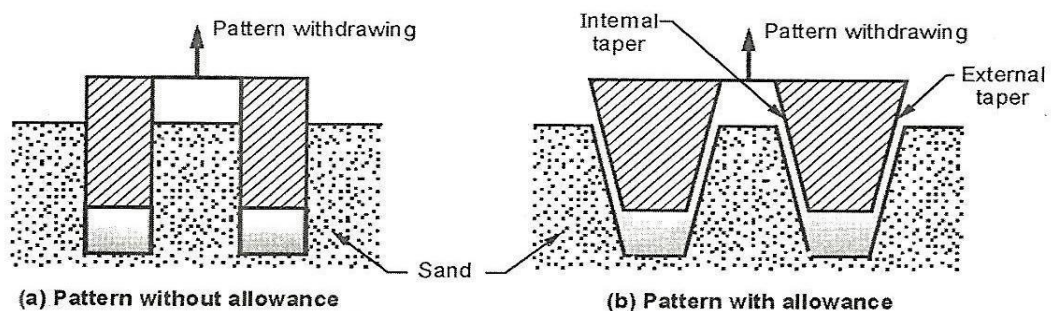

Figure 1.2: Taper or Draft Allowance

(d) Distortion allowance (Camber allowance)

The tendency of distortion is not common in all the castings.

The casting will distort or warp if:

- It is of irregular shape.
- It is of U or V-shape.
- The arms having unequal thickness.
- One portion of the casting cools at a faster rate than the other.

To eliminate this defect, an opposite distortion is provided on the pattern, so that the effect is balanced and correct shape of the casting is produced. The amount of distortion allowance varies from 2mm to 20mm as per the size, shape and casting material. Refer Fig.1.3.

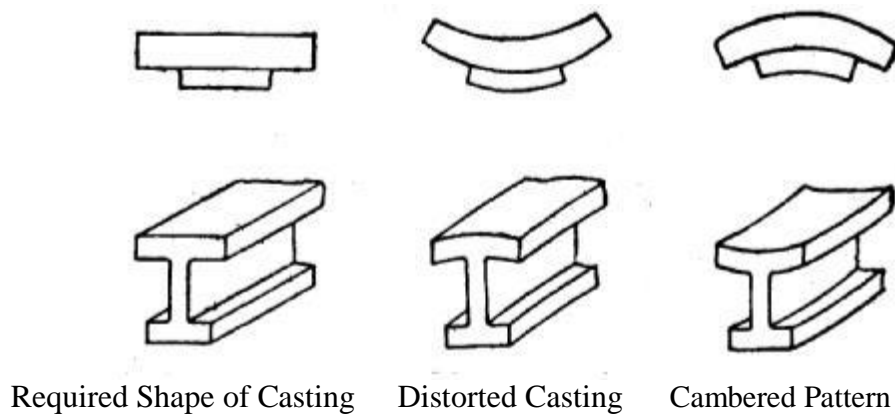

Figure. 1.3. Distortion or Camber Allowance

(e) Rapping or Shake allowance

When a pattern is to be taken out from the mould, it is first rapped or shaken by striking it with a wooden piece from side to side. This is done so that the pattern surface becomes free from adjoining sand of the mould. Due to this, there is little increase in the size of the mould cavity. For this purpose, a negative allowance is provided on the pattern i.e. the dimensions are kept smaller. It is normally provided only to the large castings and negligible for small and medium sized castings.

1.7 Types of Patterns

The type of pattern to be used for a particular casting will depend on following factors:

- Quantity of casting to be produced
- Size and shape of the casting
- Type of moulding method
- Design of casting

The various types of patterns which are commonly used are as follows:

1. Single piece or solid pattern
2. Two piece or split pattern
3. Loose piece pattern
4. Cope and drag pattern
5. Gated pattern
6. Match plate pattern
7. Sweep pattern
8. Skeleton pattern
9. Segemental pattern
10. Shell Pattern

1. Single piece or solid pattern

- It is the simplest of all the patterns and it is made in one-piece and does not carry loose pieces or joints. Refer Fig. 1.4.
- It is generally used for making large sized simple casting.
- It is less expensive as compared to other types of pattern.
- Depending upon the quantity of the casting to be produced, it is usually made up of wood or metal.
- For making the mould, single piece pattern is used either in the cope or in the drag.
- Stuffing box of steam engine can be cast by using single piece pattern.

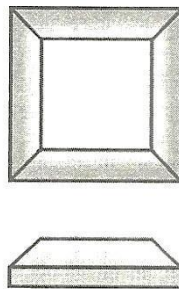

Figure: 1.4 Single piece or solid pattern

2. Two piece or split pattern

- Patterns of complicated shape castings cannot be made in one-piece because of the difficulties associated with the moulding operations.
- Such patterns are made in two pieces, called as split pattern or two piece pattern. Refer Fig. 1.5 (a)
- Its upper and lower parts are accommodated in the cope and drag portions of the mould, respectively.

- For keeping the alignment between the two parts of the pattern, dowel pins are used.
- Patterns of more complicated casting are made in more than two pieces for their easy removal and they have three piece flasks for the moulding purpose. Refer Fig. 1.5 (b).
- Casting of taps and water stop cocks are produced by using split patterns.

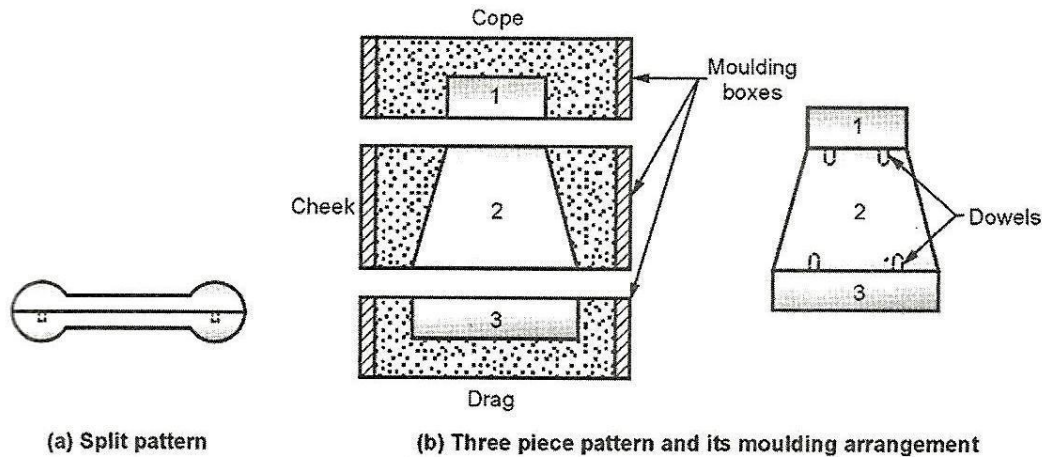

Figure: 1.5 split pattern

3. Loose piece pattern

- Some patterns embedded in the moulding sand cannot be withdrawn, hence such patterns are made with one or more loose pieces for their easy removal from the moulding box.
- These patterns are known as loose piece patterns. Refer Fig. 1.6.
- Loose pieces like A and B as shown in Fig. 1.6. remain attached with the main body by using dowel pins.
- These pattern consume more time for moulding operation and require more labour work.

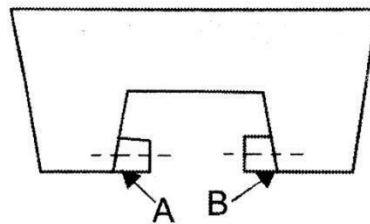

Figure: 1.6 Loose piece pattern

4. Cope and drag pattern

- It is another form of split pattern.
- The pattern is split about a suitable surface or line.
- Each half of the pattern is fixed to a separate plate and besides the pattern it has provision for moulding runner and gates.
- Each half of the pattern is moulded separately in a separate moulding box and then assembled for pouring.
- These patterns are used for producing large casting.

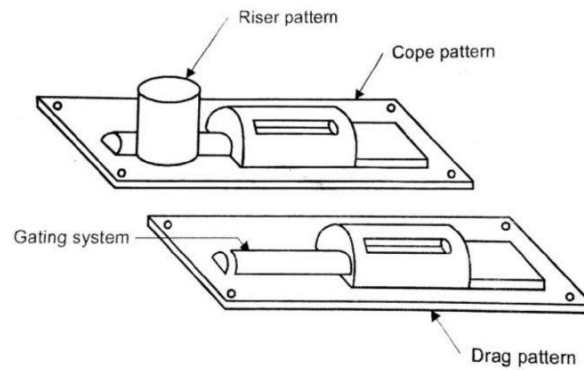

Figure: 1.7. Cope and drag pattern

5. Gated pattern

- To increase the strength and reduce the tendency to warp, gated patterns are generally made of metals.
- By using gated patterns number of casting can be made at a time, hence they are used in mass production system.
- The sections connecting various patterns serve as a runner and gates. Refer Figure 1.8.
- This facilitates filling of the mould with molten metal in better manner and reduces the required time and labour work.
- These pattern are used for producing small castings.

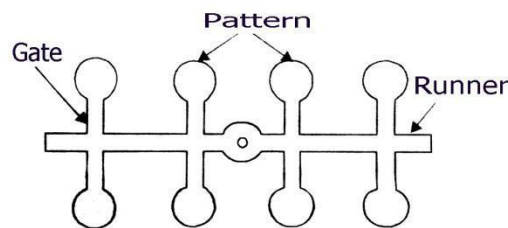

Figure: 1.8 Gated pattern

6. Match plate pattern

- These patterns are made in two pieces i.e. one piece mounted on one side and the other on the other side of the plate, called as match plate.
- The plate may carry one pattern or group of patterns mounted in the same way on its two sides. Refer Figure 1.9.
- The plate can be of wood, aluminum, magnesium or steel.

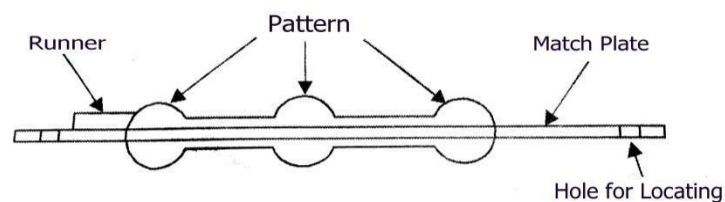

Figure: 1.9 Match plate pattern

- The match plate has runner and gates attached with it.
- Match plate patterns are generally used in machine moulding because they produce accurate casting at faster rates.
- Piston rings of an I.C. engines are made by using these patterns.

7. Sweep pattern

- Sweep pattern is just a form made on a wooden board which sweeps the casing shape into the sand all around the circumference.
- The equipment consists of a base, placed in the sand, vertical spindle and a wooden template called as sweep.
- The sweep is rotated about the spindle or post, to form the cavity as shown in Figure 1.10.
- Once the mould is ready, sweep pattern and post can be removed.
- It saves lot of time and labour work as compared to making a full pattern.
- Sweep patterns are used for making large casting of circular sections and symmetrical shape; for example, large kettles of cast iron.

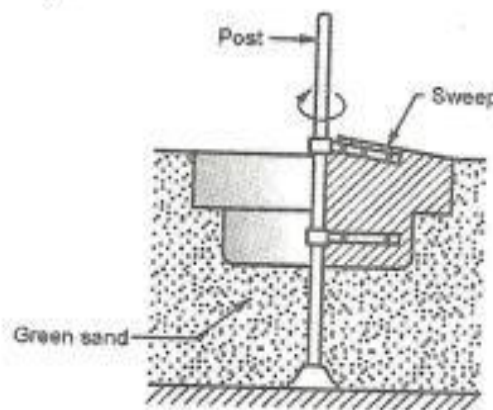

Figure: 1.10 Sweep pattern

8. Skeleton pattern

- When the casting size is very large, but easy to shape and few are to be made, then it is not economical to make a large solid pattern of that size.
- In such cases, a pattern consisting of a wooden frame and strips is made which is called as skeleton pattern.
- It is filled with loam sand and rammed.
- A strickle is used for giving the desired shape to the sand and for removing the extra sand.
- Figure shows the skeleton pattern for a hollow pipe. Skeleton patterns are used for producing large casting like turbine casting, water pipes, L-bends, etc.

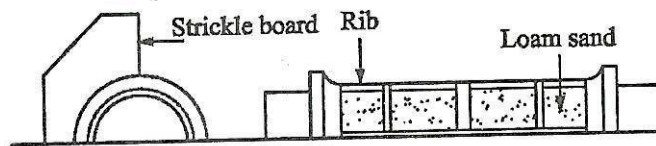

Figure: 1.11 Skeleton pattern

9. Segmental pattern

- The working principle of segmental pattern is similar to sweep pattern.
- The main difference between them is that, a sweep is given a continuous revolving motion to generate the required shape, whereas a segmental pattern is a portion of the solid pattern itself and the mould is prepared in parts by it.
- It is mounted on a central pivot and it completes one portion of the mould and then moves to the next portion. Refer Figure 1.12.
- These patterns are used for producing large circular casting like big gears, wheel rims, etc.

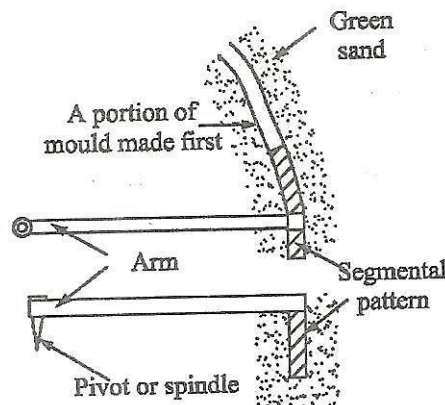

Figure: 1.12 Segmental pattern

10. Shell Pattern

- It shell pattern is used to molding of hollow shape product with curved or straight.
- It means of pipe work done it process.
- Pattern usually made of metal.
- That pattern parted along with the center line and both halves are doweled.

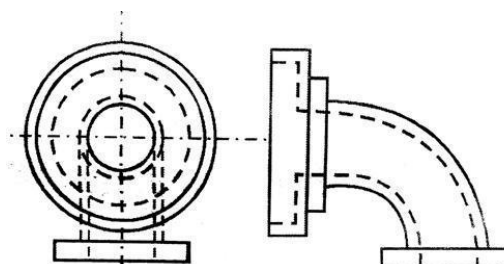

Figure: 1.13 Shell Pattern

1.8 Pattern Colours

Actually, there is no universal standard for representation of various types of surfaces by different colours. This varies with different countries and sometimes with different manufacturers also. Patterns are provided with certain colours and shade for following reasons:

1. To identify quickly the main pattern body and different pattern parts.
 2. To indicate the type of the metal to be cast.
 3. To identify loose pieces, core prints, etc.
 4. To visualise machined surfaces, etc.
-
1. Cast surfaces to be machined-Red.
 2. Surfaces to be left unmachined – Black.
 3. Core print seats – Yellow.
 4. Loose piece and seatings – Red strips on yellow base.
 5. Parting surfaces – Clear or no colour
 6. Supports or stop-offs –Black strips on yellow base.
 7. Core prints for machined castings – Yellow strips on black background.

1.9 Mould Materials

Mould material is the one out of which a mould is made. Mould material should be such that, the cavity of the mould retains its shape till the metal has solidified. Casting can be made in permanent mould (made of ferrous metals and alloys) or temporary refractory moulds (made of refractory sands and resins). Moulds can also be made up of wax, carbon, plaster of paris, ceramics, etc. permanent moulds are used for low melting point materials and they are also costly. Hence, most of casting are produced by using refractory mould materials mainly refractory sands.

The choice of a particular mould material depends on the following factors:

1. Cost of the material
2. Quality of casting required
3. Number of casting required
4. Shape and size of the casting
5. Accuracy of the casting
6. Material to be cast, etc.

1.9.1 Moulding Sand

Sand is the most widely used mould material for casting ferrous and non ferrous metals from few grams to few tons. The main reason for this is that, the sand fulfills service

requirements at reasonably lower cost than the other materials. When the sand is properly mixed with other elements, it constitutes one of the best materials for the mould. The sources of moulding sands are river beds, lakes, sea and deserts.

1.9.2 Types of Moulding Sand

All types of sands used in the foundry can be grouped as:

1. Natural sand
2. Synthetic sand
3. Special sands

1. Natural sand

Natural sand can be used directly for making moulds as soon as it is received from its source. It contains binding materials (5 to 20% clay) and needs only water (5 to 8%) to mix before making the mould. It can maintain moisture content for a long time and also contain considerable amount of organic matter. This type of sand permits easy patching and finishing of moulds. Natural sands are less refractory than synthetic sands and also less costly. Hence, natural sands are used for cast iron and non ferrous casting.

2. Synthetic sand

Synthetic sand consists of natural sand with or without clay, moisture and binder like bentonite. Hence, this sand is a formulated sand. These types of sand are used for steel and other ferrous and non-ferrous alloy casting.

Synthetic sand has following advantages as compared to natural sand:

- It requires less proportion of binder.
- Higher refractoriness and permeability.
- Properties can be easily controlled.
- Refractory grain size is more uniform
- It is more suitable in mass production and mechanized foundries
- It requires less storage space.

3. Special sands

The special sand includes green sand, loam sand, core sand, parting sand, facing sand and backing sand.

a) Green sand

It is the sand which is in condition and contains 5% of water and 15 to 30% of clay. Moulds and cores both can be made up of green sand. Green sand moulds are poured in the green condition (not dried). It is preferred for producing simple, small and medium sized casting.

b) Loam sand

It contains more amount of clay as compared to other sands i.e. upto 50% loam sand dries hard. Its ingredients are fine sand, finely ground refractories, clay, graphite and fibrous reinforcement. It is used for heavy and large parts.

c) Core sand

Core sand is different from moulding sand as it has very low clay content and their grain size is large to increase the permeability. It is silica sand mixed with core oil which is composed of linseed oil, resign, light mineral oil and other binding materials. Core sand is a suitable sand mixture, also used for making cores.

d) Parting sand

It consists of dried silica sand, sea sand or burnt sand. It is used to keep the green sand from sticking to the pattern and also to allow the sand on the parting surface of the cope and drag to separate without clinging. Its parting compounds may be dry or liquid. Dry parting substances are charcoal, ground bone and limestone, ground nutshells, etc. whereas liquid substances are petroleum jelly mixed with oil, paraffin and stearic acid.

e) Facing sand

It is fresh and specially prepared moulding sand which covers the pattern all around it, thus forms the face of the mould cavity. It comes in direct contact with the molten metal being poured; hence it should possess much improved properties than other sands. Its use reduces the mould material cost. Various facing materials are plum bags, graphite, talc, molasses, etc.

f) Backing sand

It is the sand which backs up the facing sand and does not come in direct contact with the pattern. This sand has black colour and hence, sometimes called as black sand. It should be cleaned off the foreign matter like fins, nails, etc. before use. It is the floor sand which can be used again and again.

1.9.3 Characteristics of Moulding Sand

Moulding sand is used to produce sound castings. Hence, it should possess following desirable properties:

1. Flowability or plasticity

It is the ability of the moulding sand to get compacted to a uniform density. It assists moulding sand to flow and pack all-around the pattern and take up the desired shape. It increases with the amount of clay and water.

2. Green strength

It is the strength of the sand in the green or moist condition. A mould which has adequate green strength will retain its shape and does not distort or collapse, even after the pattern has been removed from the moulding box. It helps in making and handling the moulds. If the mould is hardened in contact with the pattern surface with adequate green strength, then high degree of dimensional accuracy and stability can be obtained.

3. Dry strength

It is the strength of the moulding sand in the dry state. A sand must have sufficient dry strength to withstand erosion of the mould walls and enlargement of mould cavity during the flow of molten metal. It is related to grain size, binder and water content.

4. Permeability or porosity

Molten metal always contain some amount of dissolved gases which are evolved when the metal solidifies. Also, when the molten metal comes in contact with moist sand, it generates steam or water vapour. If these gases and water vapour generated by moulding sand do not find opportunity to escape completely through the mould, then they will form gas holes and pores in the castings. Hence, the sand must be porous to allow the gases and steam generated within the moulds to be removed freely. This property of sand is known as permeability or porosity.

5. Refractoriness

It is the ability of moulding sand to withstand high temperatures without fusion, cracking and buckling, hence facilitating a clean casting. The amount of this property depends upon the metal which is to be cast. If sand lacks this property, then it slags on the surface of the mould and smooth casting surface can be obtained.

6. Adhesiveness

It is the property of moulding sand because of which it is capable of adhering to the surface of other materials. Also, with this property gagers are able to hold bulky sand projections of the mould. Due to this property, the heavy sand mass is successfully held in a moulding flask and manipulated as required, without any risk of its falling down.

7. Cohesiveness

It is the property of the sand due to which sand particles stick together. This property helps in withdrawing the pattern from the mould without damaging the mould surfaces and edges. Due to cohesiveness, the mould faces get adequate strength to withstand the pressure of the flowing molten metal and do not get washed under this pressure. This property is similar to the green strength. It depends upon the grain size, clay and moisture content.

8. Thermal stability

To avoid breaking, buckling and flaking off of mould surface at higher temperatures, sand possess dimensional thermal stability. If not, the casting may have defects like cuts and washes.

9. Collapsibility

It is the property due to which the sand mould automatically collapses after freezing of the casting, to allow the free contraction of the metal. If this property of the sand is absent, then the casting will result in tears and cracks.

1.9.4 Constituents of Moulding Sand

The main constituents of Moulding are

1. Sand
2. Binder
3. Additives
4. Water

1. Sand

The sand which form the major portion of the moulding essentially a silica grain. It is river sand which is used with or without washing. The shape of the grains may be round, sub angular, angular or very angular. The shape and size of the grains have more void space between the grains which increase permeability, whereas a fine grain lowers the permeability. Silica sand, with rounded grains, gives much better compatibility as compared to angular grains, because sand with rounded grains has the greatest degree of close packing of particle.

2. Binder

Moulding sand binders are refractory as compared to moulding sand. Binders produce cohesion between the moulding sand grains in the green or dry condition. They give strength to the moulding sand so that it can retain its shape as mould cavity. If the amount of binder increases, permeability of moulding sand decreases. The most commonly used binders are as follows:

- Organic binders
- Inorganic binders

Organic binders are mostly used for making. The common binders in this group are

- a) Linseed oil
- b) Dextrin
- c) Molasses
- d) Pitch

Commonly used inorganic binders are clay, sodium silicate and Portland cement. Clay binder which is most widely used have following types

- a) Bentonite
 - b) Fire clay
 - c) Limonite
 - d) Ball clay
 - e) Kaolonite
- Out of these clay binders, bentonite most commonly used.

3. Additives

The basic constituents of moulding sand mixture are sand, binder and water. Materials other than the basic ingredients are also added to the moulding sand mixtures in small quantities for the following purposes

- To enhance the existing properties.
- To develop certain other properties like resistances to sand expansion defects, etc.

The most commonly used additives are as follows:

a) Coal dust

It is mostly used in the sand for the grey iron casting. It reacts chemically with the oxygen present in the sand pores and thus, produces a reducing atmosphere at the mould metal interface and prevents oxidation of the metal. It reduces cohesiveness and strength of the sand.

b) Sea coal

It is a finely ground soft coal and is widely used in sands for grey iron castings. It restricts the movement of the mould wall and improves surface finish. It reduces hot strength and permeability of the mould and requires more amount of water in the sand.

c) Cornflour or cereals

It promotes wall movement of the mould by being volatized by heat and reduces expansion defects. It improves the strength, toughness and collapsibility and reduces permeability and flowability of the sand. Its proportion in the sand varies from 0.25 to 2.0%.

d) Silica flour

It increases hot strength and decreases metal penetration into the mould. It reduces expansion defects and improves surface finish. It may be added upto 35%.

e) Wood flour

It promotes wall movement of the mould. It reduces expansion defects; increases collapsibility; improves surface finish and thermal stability of the mould. It may be added from 0.5 to 2.0%.

f) Pitch

It increases hot strength and surface finish on ferrous casting. It is added upto 2.0%; if higher proportion is added it reduces the green strength.

g) Fuel oil

It is added to reduce the requirement of the free water in the sand.

h) Dextrin and molashes

Its addition increases the dry strength of the mould. It is almost similar to cornflour.

4. Water

The amount of clay added to the moulding sand will not give the required strength and bond, until a suitable quantity of water is mixed with it. The amount of water may vary from 1.5 to 8.0%. Water added to the sand mixture partly gets absorbed by clay and partly remains free, which is called as free water. The free water acts as a lubricant and affects following properties:

- It increases plasticity.
- It improves mould ability.
- It reduces the strength of the sand mixture.

For given amount of clay and its types, there is an optimum requirement of the water. If the amount of water is less, it does not develop proper strength and plasticity, whereas if water content is more, then it results in excessive plasticity and dry strength.

1.10 Sand Preparation and Conditioning

The best selected sand and binders will not produce good casting, until they are properly and efficiently mixed and prepared. Sand preparation means mixing the moulding sand ingredients such as sand, binder, moisture and other additives. Mixing can be done manually or by using mechanical mixers. An operation in addition with sand preparation is called as sand tempering, which is a process by which adequate amount of moisture is added to the moulding sand to make it workable. Sand conditioning consists or preparing of the moulding sand, so that it becomes suitable for moulding purposes.

Functions of sand preparation and conditioning

The functions of sand preparation are as follows:

- To develop optimum properties in the moulding sand.
- To obtain even distribution of sand grains throughout to bond.
- To add suitable amount of water to activate clay binder.
- To deliver sand at the suitable temperature.
- To remove impurities from the moulding sand.

Steps involved in preparation of sand

- Remove all the impurities and underivable matters such as nails, fins, hard sand lumps, etc.
- With the help of mechanical mixer i.e. Muller, start the mixing of sand ingredients in dry state.
- Temper the moulding sand ingredients and continue mixing or mulling action till there is a uniform distribution of the ingredients.

- Then the sand is treated by an Aeration Process which separates sand grains into individual particles.
- Aerated sand is easy to handle and use and provides better moulding results.
- Aeration is achieved by power operating riddles, screening, beating the sand or by passing the sand stream over toothed belt.
- To avoid difficulites in mould making, sand is cooled below 37°C.

Working of Muller

- A continuous mixing or mulling action is very much required for mixing sand, binder and moisture thoroughly.
- It is carried out by using hand shovels or mechanical mixers i.e. Muller.
- Hand mulling is suitable for natural sand but not for synthetic sand.
- A muller kneads, shears, slices through and stirs the sand with the help of revolving wheels or rollers.
- During the process two wheels along with two plows roll and rotate in a circular path about the horizontal axis.

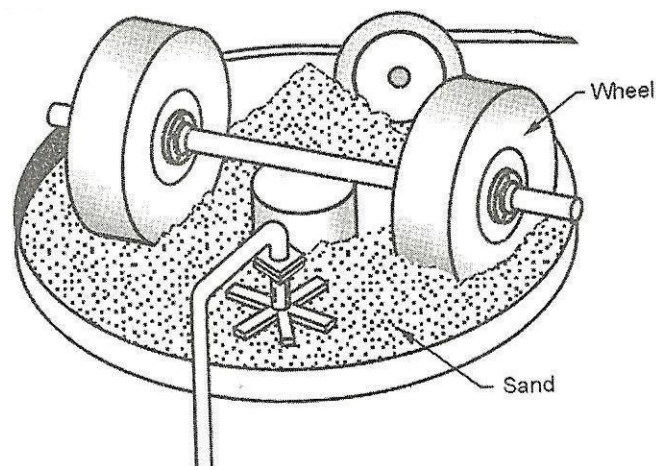

Figure 1.14 Moulding sand muller

- Wheels either rest on the sand or remain about 5 mm to 10 mm above the base of the rotating pan.
- The wheels may move with the stationary held pan or the wheels may be mounted rigidly with the rotating pan. Refer Figure1.14.
- Plows stir the sand and bring it under the wheels, whereas wheels mix the sand with a squeezing action.
- After mixing of the sand, it may be taken out from a drop door, which is provided at the bottom of the muller.

1.11 Sand Testing

Production of sound casting mainly depends upon uniform and good quality of moulding sand. Hence, the moulding sand is expected to have many good properties. These properties depend on the shape and size of sand grains and the amount and distribution of the other constituents added to the sand. In order to control these factors effectively, a number of tests are performed in foundry laboratories, which indicates the moulding sand performance and helps the foundrymen in controlling the moulding sand properties. Some of the common tests which are performed in the foundry laboratories are as follows:

1. Moisture content test
2. Clay content test
3. Permeability test
4. Grain fineness test
5. Mould hardness test
6. Refractoriness test
7. Compression strength test

Sample preparation

The tests are conducted on a sample of standard sand. The samples are prepared by ramming sand in a specimen ram tube on sand rammer. The shape of the sand samples varies as per the nature of the test. Various sand samples used in testing are:

- Cylindrical green sand sample, for testing compressive and shear strength and permeability.
- Dry sand core specimen for bending test and tensile strength test.

1.11.1 Moisture Content Test

- Moisture is one of the most important factors which control the properties of moulding sand.
- Low moisture in the moulding sand does not develop strength properties and high moisture decreases permeability and adds to other problems associated with moulding operations.
- The moisture content test is carried out by using separate moisture determining apparatus.
- It consists of a cast iron base, an infrared heating bulb fitted in a shade and a drying pan with handle. Refer Figure 1.15.

Procedure

- 20 to 40 grams of prepared sand sample is placed in the pan.
- The pan is slid and fitted under the shade and the bulb is switched on.
- It is heated by an infrared heater bulb for 2 to 3 minutes.
- The moisture in the moulding sand is thus evaporated.
- The switch is put off; pan removed and sample is reweighed.

- The percentage of moisture can be calculated from the difference in weights of the original moist and the consequently dried sample of the sand.
- It is then expressed as a percentage of the total weight of the sand sample.

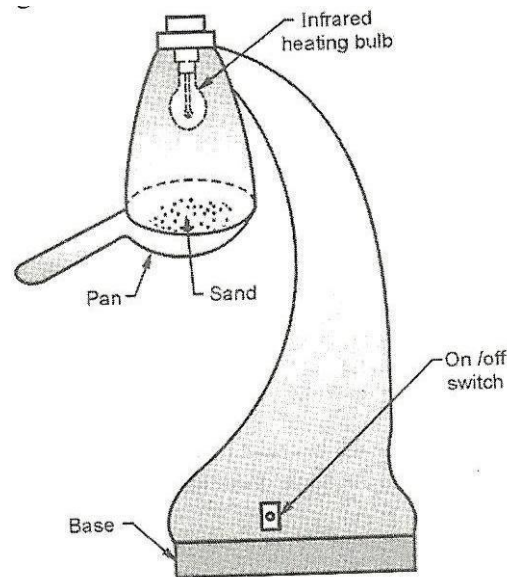

Figure 1.15 Moisture Determining Apparatus

1.11.2 Clay Content Test

- For testing purposes the clay in the moulding sand is defined as particles which fail to settle one inch per minute when suspended in water.
- These are generally less than 20 microns.
- The apparatus used for the purpose is called as mud or clay content tester.
- It consists of a cast iron base, stirring shaft with paddles driven by an electric motor and an adjustable support for the glass beaker.

Procedure

- Take a sample of 50 grams of dry sand which is dried at 105°C for an hour.
- Place a sample in a wash bottle and add 475 ml of distilled water and 2.5 to 3% of NaOH.
- Stir the contents for 5 minutes using stirrer.
- Fill the wash bottle with water upto the mark indicated on it (generally 6 inches).
- After the sand, etc. has settled for about 10 minutes, siphon out the water from the wash bottle, which leaves a minimum depth of water i.e. one inch in the bottom of the wash bottle.
- Add more water to the sand thus left in the was bottle and stir the constituents again till the sand settles down.

- Repeat the above step until the water over the settled sand is clean, which assures that the whole amount of clay has been removed from the sand.
- The bottle is placed in an oven and after the sand is dried out, a sample is weighed.
- The percentage of the clay is determined by the difference in the initial and the final weights of the sample.

1.11.3 Permeability Test

Permeability is that property of moulding sand which permits the escape of water vapour (steam) and other gases generated in the mould during hot metal pouring.

- Permeability depends on the following factors:
 - Grain shape and size
 - Grain distribution
 - Binder and its contents
 - Water amount in the moulding sand
 - Degree of ramming

Before permeability test, a standard sized sand specimen is rammed by a specimen rammer. For measuring the permeability of sand, a permeability tester is used which consists of following parts (Refer Figure 1.16)

- An inverted bell jar, which floats in a water seal and it can permit 2000 c.c. of air to flow.
- Specimen tube for holding the sand specimen.
- A monometer for measuring air pressure.

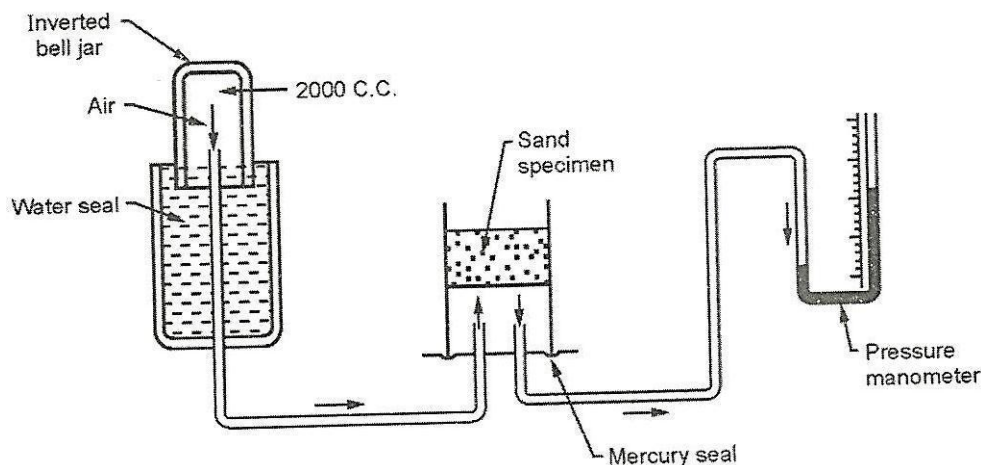

Figure 1.16 Permeability Tester

Procedure

- 2000 c.c. of air is held in an inverted bell jar and forced to pass through the sand specimen.

- A situation comes when the air entering in the specimen is equal to the air escaped through the specimen.
- It gives a stabilised pressure reading on the manometer and it can be read on the provided scale.
- At the same time, the time required for the 2000 c.c. of air to pass through the specimen of sand is recorded by using stop watch.
- Finally, calculate the permeability by using following relation: Permeability Number =

Where, V = Volume of air passing through the specimen in c.c.

(standard values is 2000 c.c.)

h = Height of the specimen (standard value is 5.08 cm)

a = Areas of the specimen in cm^2 (standard value is 20.268cm^2) P = Air pressure is gm/cm²

t = Time taken by 2000 c.c. of air to pass through the sand specimen in minutes.

Permeability number = _____

1.11.4 Grain Fineness Test

- This test determines the grain size, distribution and grain fineness.
- It is performed on the dried sample for which all clay substances have been removed.
- The grain size of moulding sand provides a significant effect on its permeability.
- The apparatus required for determining grain fineness number is shown in Figure 1.17.

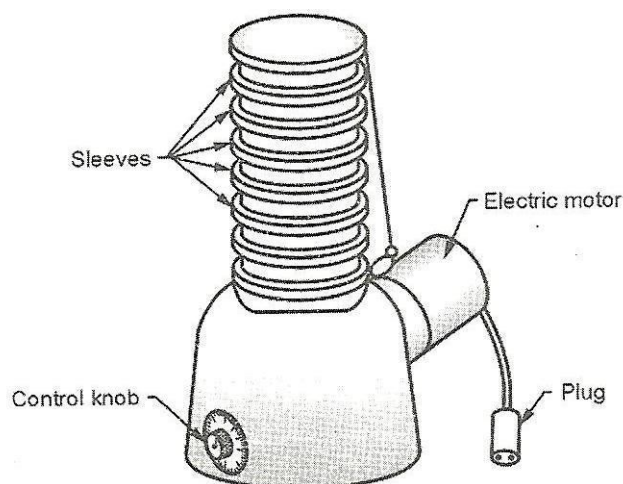

Figure 1.17 Grain Fineness Tester

- It consists of a number of standard sleeves mounted one above the other on a power driven shaken.
- There are eleven standard sleeves mounted one above the other and a pan is placed under the bottom – most sieve.
- The coarsest sleeve is placed at the top and finest sieve at the bottom.
- The rest being placed below one another in order of fineness from top to bottom.
- The whole unit is shaken by an electric motor.
- The sample of dry sand, which is free of clay, is placed in upper-most sleeve and sand is vibrated for definite period of time.
- The amount of sand retained on each sleeve is weighed and percentage distribution of grains is found.
- To obtain the American Foundry Association (AFA) fineness number, the weight of sand on each sleeve and pan is multiplied by a factor shown against each sleeve and pan as show in the table1.2.
- The grain fineness number is obtained by adding all the resulting products and diving the total by percentage of sand grains retained.

AFA grain fineness number

$$= \frac{\text{Sum of products}}{\text{Percentage of sand grains retained}}$$

Table 1.2 AFA Fineness Calculations

Mesh	6	12	20	30	40	50	70	100	140	200	270	Pan	Total
% retained	0	0	0	2.0	2.5	3.0	6.0	20.0	32.0	12.0	9.0	4.0	90.5
Multiplier	3	5	10	20	30	40	50	70	100	140	200	300	
Product	0	0	0	40.0	75.0	120.0	300.0	1400.0	3200.0	1680.0	1800.0	1200.0	9815.0

Grain fineness number = $\frac{9815.0}{90.5}$

1.11.5 Compression Strength Test

- The compression strength testing apparatus for sand is shown in Figure1.18.
- It consists of hand wheel which is rotated to build up the hydraulic (oil) pressure on the specimen.

- For measuring the deformation occurring in the specimen the dial indicator is provided on the apparatus.
- There are two indicators are provided on the apparatus. The first one is used for testing low strength sands (moulding sands) and the second one is used for testing high strength sands (core sands).
- The same apparatus is also used for testing the tensile strength, shear strength, transverse strength, etc. of sand.

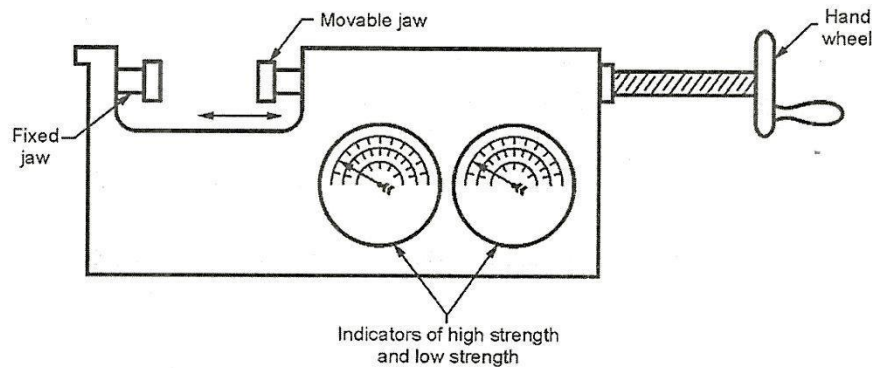

Figure 1.18 Compression Strength Testing Equipment

1.12 Core

Core is a sand shape or form which makes the contour of a casting for which no provision has been made in the pattern for moulding. Core may be made up sand, plaster, metal or ceramics. Core is an obstruction which when positioned in the mould, does not permit the molten poured metal to fill the space occupied by the core hence produce hollow casting. Cores are used as inserts in moulds to form design features which are difficult to be produced by simple moulding.

Functions of core

- Core provides a means of forming the main internal cavity for hollow casting.
- Core provides external undercut feature.
- Cores can be inserted to obtain deep recesses in the casting.
- Cores can be used to increase the strength of mould.
- It can be used as a part of gating assembly.
- It can form a part of green sand mould and can also be used to improve the mould surface.

Essential characteristics of core

A dry sand core must possess following properties:

- It should have sufficient strength to support itself without breaking.

- It should have high permeability and high refractoriness.
- It should have smooth surface to ensure a smooth casting.
- It should have high collapsibility, to assist the free contraction of the solidifying metal.
- It should have those ingredients which does not generate mould gases.

Core applications

Core and its form increases the versatility of moulding processes and operations. In addition to recess forming and holes in the casting, cores are used as follows:

- Cores are used for mould making.
- Cores can be used as strainer, gates and pouring cups.
- Cores are used for increasing production from match plate pattern.
- Cores can be used as core mould in centrifugal casting process.
- Also it can be used as slab core for increasing casting output from one mould.

1.12.1 Core Sand and its Ingredients

- Core sand is a sand mixture suitable for cores.
- Core sand mixture consists of sand grains, binders for green and cured strength and other additives used for special purposes.
- The commonly used core sand mixture consist of sand, 1% core oil, 1% cereal and 2.5 to 6% of water.
- Core sand is almost similar to moulding sand but the main difference is that core sand has very low clay content and larger grain size.
- Large grain size assures higher permeability.

Core sand ingredients

Core sand ingredients or core materials are as follows:

(a) Granular refractories:

Some of the commonly used granular refractories

- are:
- Dry silica sand
 - Carbon
 - Zircon
 - Olivin
 - Chamotte

(b) Core binders

A core binger is used to, Hold sand grains together. Give strength to cores. Make the cores erosion resistant. Impact adequate collapsibility to cores. Core binders are of following types:

- Organic binders (core oil, cereal, pitch, woodflour, synthetic resins, etc.)
- Inorganic binders (fire clay, bentonite, silica flour, iron oxide, etc.)
- Other binders (cement, sodium silicate, etc.)

(c) Water

In a core sand mixture, water content may vary from 3 to 7%. Binders and additives work only when moisture is present. Correct amount of water develops good green strength, edge and scratch hardness, good tensile strength, etc. Excessive amount of moisture adds difficulties in making and baking of cores.

(d) Additives

The additives used for core sand are almost similar to moulding sand, hence Refer section 1.9.4.

1.12.2 Core Making

Core making basically consists of following steps:

1. Core sand preparation
2. Core making
3. Core baking
4. Core finishing or dressing
5. Setting the cores

1. Core sand preparation :

Core sand preparation is similar to moulding sand preparation. Refer section 1.10.

2. Core making :

Small cores can be made manually in hand rammed core boxes. Cores on mass scale are rapidly produced on various core making machines which are,

- Jolt machine
- Shell core machine
- Core blower
- Sand slinger
- Core rollover machine
- Core extrusion machine

3. Core baking :

- After the cores are prepared they are baked in baking furnace where the moisture is removed from the core.
- In the green state, cores have round shape hence they are placed on the core plate for baking, where they tend to flatten.
- The special shapes, which support the green sand cores having curved surfaces, are known as core driers.
- After supporting on the core drier, they are sent to ovens for baking.

- The core oven may be batch type or continuous type.

4. Finishing of cores :

- After baking cores are given certain finishing operation before they are finally set in the mould.
- The fins and other sand projections are removed from the sand surface of the cores by rubbing or filing, to bring them to correct dimensions and to provide a good surface finish.
- The cores are also coated with refractory or protective materials to improve their refractoriness.
- The surface may be coated with heat resistant paint.
- Core coating materials are finely ground graphite, silica and zircon flour.
- Finally core assembling is done; it means two or more parts of the core are joined together by pasting, welding or bolting before the core can be set in the mold.

5. Setting the cores

Core setting means placing cores in the mould. To obtain correct cavities in the casting, the cores should be accurately positioned in the moulds.

1.13 Types of Cores

Various types of cores of different designs and sizes are used in different ways in foundry work. A general way of classifying them is, according to their shapes and positions in the prepared moulds. Their main types are as follows:

1. Horizontal core
2. Vertical core
3. Hanging core
4. Balanced core

1. Horizontal core

- A horizontal core is positioned horizontally in the mould. Refer Figure 1.19.
- According to the shape of the cavity required in the casting, a horizontal core may have any shape.
- Uniformly sectioned horizontal cores are mostly placed at parting line.

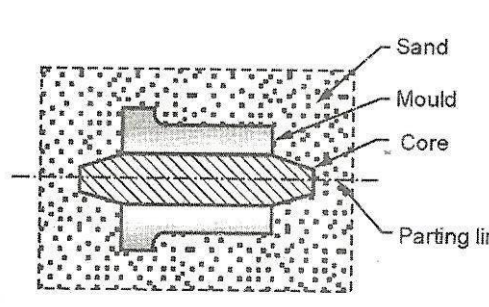
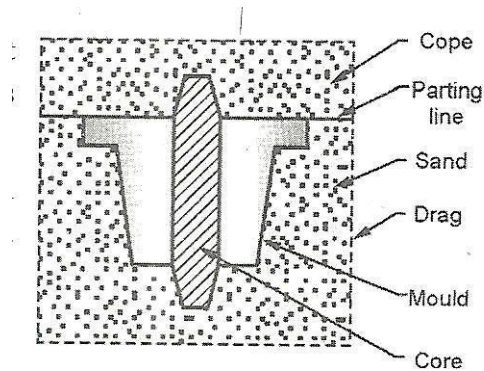

Figure 1.19 Horizontal Core

2. Vertical core

- It is similar to horizontal core, except that it is fitted in the mould with its axis vertical. Refer Figure 1.20.
- The top end of the core is provided with more amount of taper, to have a smooth fitting of the cope on the core.
- A major portion of the vertical core generally remains in the drag.



1.20 Vertical core

3. Hanging core

- Hanging core is also called as cover core as shown in figure 1.21.
- It is supported from above and it hangs vertically in the mould cavity.
- It has no support from the bottom. They are provided with a hole through which molten metal reaches the mould cavity.

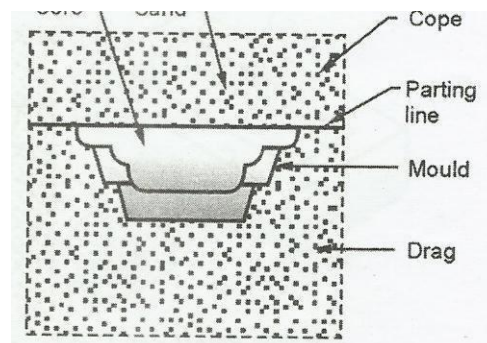

Figure 1.21 Hanging Core

4. Balanced core

- Balanced core is supported and balanced from its one end only.
- It requires long core seat, so that the cores does not fall into the mould cavity. Refer Figure 1.22.
- It may be supported on chaplets.

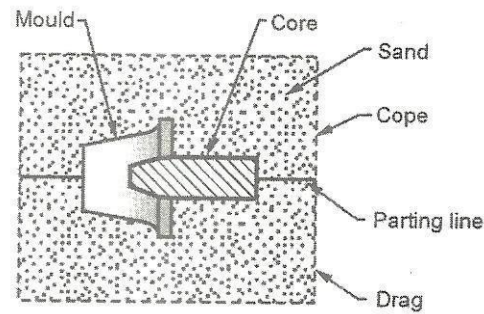

Figure 1.22 Balanced core

1.14 Core boxes

Basically, core box is a pattern for making cores. They are employed for ramming cores in them. Core boxes provide the required shape to the core sand. The commonly used types of core boxes are as follows:

1. Half core box

- Half core box is shown in Figure 1.23 which can make cylindrical cores.
- At one time, half portion of the core is made in the core box.
- After producing number of half core portions, they are cemented together to make full cylindrical cores.

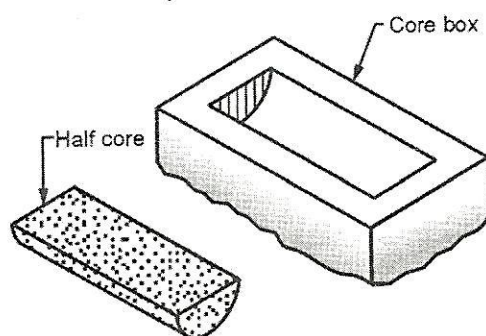

Fig. 1.23 : Half core box

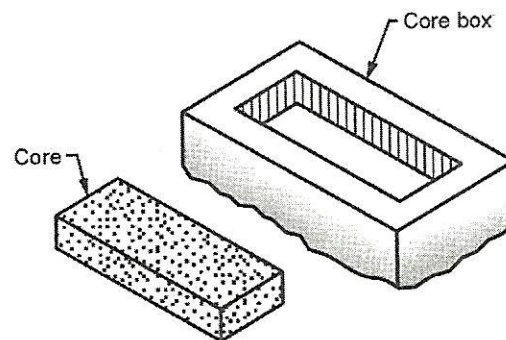

Fig. 1.24 : Dump core box

2. Dump core box

- It is also called as slab core box.
- It is similar to half core box in its construction but, it makes full core at a time, hence used to produce rectangular, square or trapezoidal cores. Refer Figure 1.24.

3. Split core box

- This type of core box moulds the entire core, but to remove the core after moulding, the box is separated in two or more parts. Refer Figure 1.25.
- Two portions of the split core box can be aligned temporarily with the help of dowels.
- For making the core, two portions of the split core box are joined and then sand is rammed.

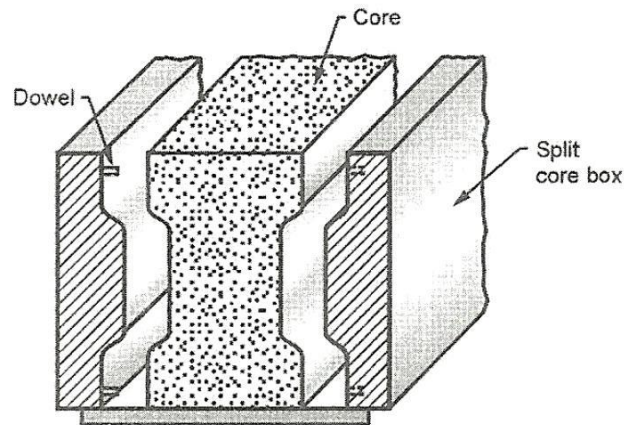

Fig. 1.25 : Split core box and rammed core

4. Strickle core box

- Sand is rammed in the dump core box.
- The top surface of the core in the core box is given a required shape by using strickle board cut and finished to the desired shape.
- A strickle board strikes off excess sand not conforming to its shape.
- A strickle board is made up of wood and in any shape, as per the requirement. Refer Figure 1.26.
- This method of producing cores is less costly as compared to others.

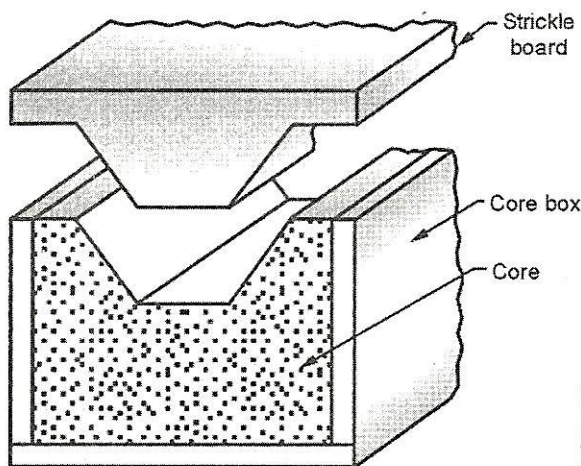

Fig. 1.26 : Strickle core boxes

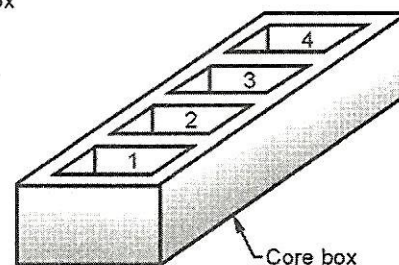

Fig. 1.27 : Gang core box

5. Gang core box

Gang core box contains a number of cavities, so that more than one core can be rammed at a time. Refer Figure 1.27.

6. Loose piece core box

- It is similar to half core box.
- But loose piece core box can produce two halves of a core, which may be neither identical in size nor in shape.
- It is achieved by inserting loose wooden pieces in the core whenever required. Refer Figure 1.28.

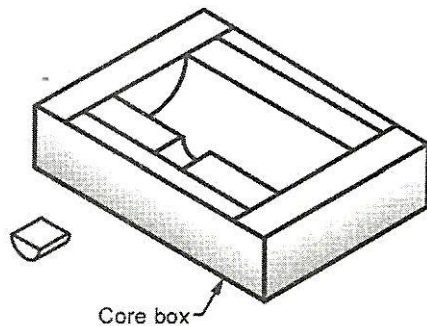

Fig. 1.28 : Loose piece core box

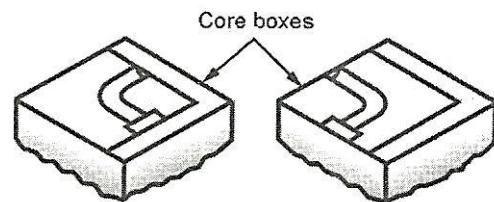

Fig. 1.29 : Left and right hand core boxes

7. Left and right hand core boxes

- These core boxes are used to make cores for producing pipe bends.
- Half of the pipe bend core is made in each core box.
- Two halves of pipe bends are then rammed, backed and joint together to form a full core. Refer Figure 1.29.

1.14.1 Core Prints

Core prints are basically extra projections provided on the pattern. They form core seats in the mould when pattern is embedded in the sand for mould making. Core seats are provided to support all the types of cores. Though the core prints are the part of pattern, they do not appear on the cast part. Figure 1.30 shows a core positioned in the core seat made by the core print provided on the pattern.

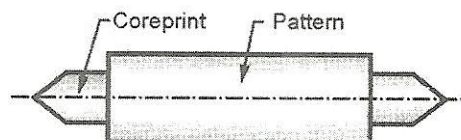

Fig. 1.30 : Core print

Core prints are of the following types:

- Horizontal core print
- Vertical core print
- Balanced core print
- Cover core print

1.14.2 Chaplets

- During the casting process, if the core gets shifted from its position in the mould, it will result in a displaced cavity and hence a defective casting is obtained.
- Hence, a core must be firmly supported in the core seat especially to overcome vertical core movement, which is due to force exerted by poured molten metal.
- For this purpose, chaplets are provided with can support the cores.
- Chaplets are metal shapes which are placed between the mould and core surfaces as shown in figure 1.31.

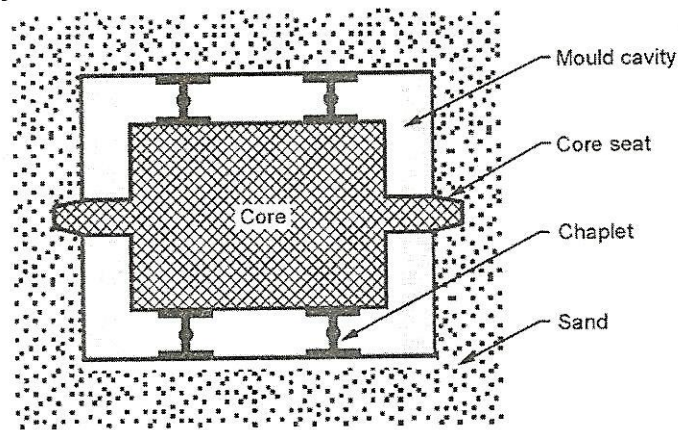

Fig. 1.31 : Cores supported between the chaplets

- As the molten metal is poured, chaplet melts and becomes a part of the casting.
- But the chaplets should be of the same material which is being cast.
- Before use, dirty, rusty, greasy or wet chaplets are properly cleaned and dried. Figure shows a number of chaplet forms and shapes available commercially.

1.15 Moulds

- Prepared moulding sand is packed rigidly around the pattern.
- When the pattern is removed, a cavity corresponding to the shape of the pattern remains in the sand which is known as mould or mould cavity.
- Hence, mould is a sort of container which when poured with molten metal produces a casting of the mould shape.
- The process of making the mould is called as mould making.

Essential characteristics

A mould should possess following properties:

- Mould should have refractoriness to bear the high heat of molten metal.
- It should have strength to hold the weight of the molten metal.
- Also, it should produce minimum amount of mould gases.

- It should be able to resist the erosive action of the molten metal being poured.
- A mould should resist metal penetration into the walls.

1.15.1 Steps in Mould Making

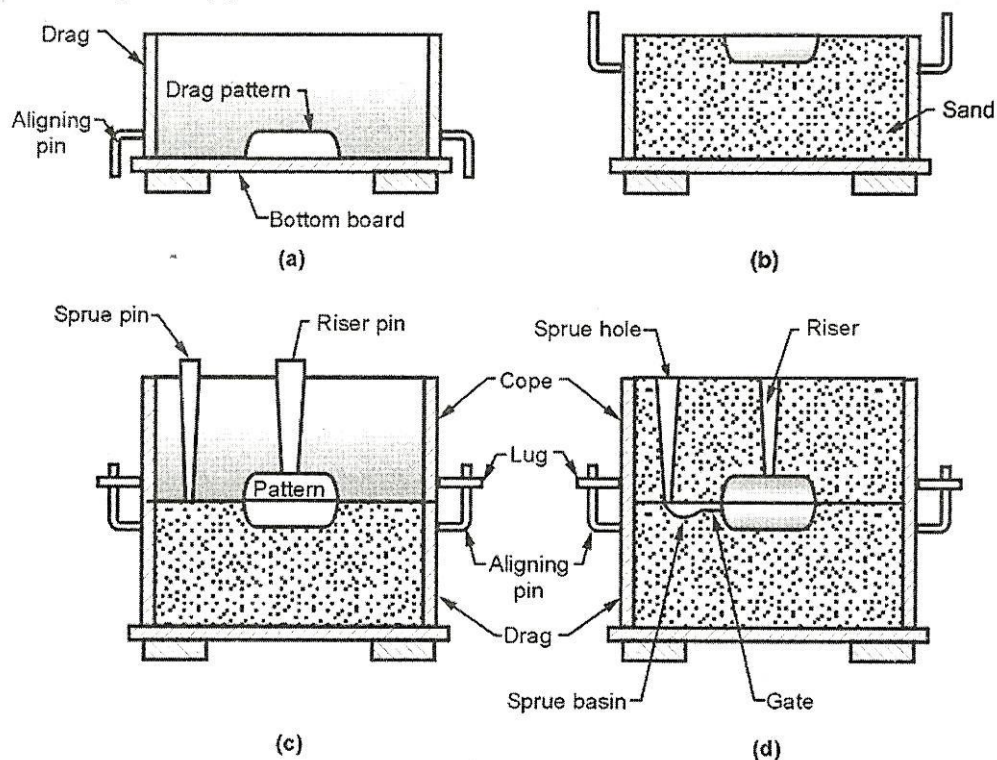

Figure 1.32 Making a mould

Steps involved in making a sand mould are as follows:

1. Select a suitable moulding box which can accommodate mould cavity, risers and gating system.
2. Place the drag half of the box on the moulding board with the aligning pins pointing downwards.
3. Place the drag pattern with parting surface down on the bottom board. Refer Figure 1.32 (a).
4. Sprinkle the facing sand all around the pattern carefully so that the pattern does not stick to the moulding sand.
5. Fill the drag half with moulding sand and ram the sand uniformly in the moulding box around the pattern.
6. Strike off the excess sand to bring it to the same level of the flask, hence drag half is completed.
7. Sprinkle parting sand over the top of the drag half and roll it over the drag. Refer Figure 1.32 (b).

8. Place the cope pattern on the drag pattern and align by using dowel pins.
9. Place cope half over the rammed drag half.
10. Sprinkle parting sand all around the cope pattern.
11. Erect sprue and rise pins to form suitable sized cavities for molten metal pouring as shown in figure 1.32 (c).
12. Fill the cope with sand and ram it.
13. Remove sprue and riser pins and vent the cope with vent wire.
14. Sprinkle parting sand over the top of the core surface and roll over the cope on the bottom board.
15. Remove both the cope and drag pattern and repair the mould, if necessary.
16. Cut the gate connecting the sprue basin with the mould cavity.
17. Apply mould coating by a swab.
18. In case of dry sand mould, bake the mould.
19. If required, set the cores in the mould.
20. By inverting cope over the drag close the mould.
21. Finally, clamp the cope with drag and the mould is ready for pouring. Refer Figure 1.32 (d).

1.16 Moulding Processes

There are different ways of classifying moulding process. Some of the common ways are as follows:

1. As per the method used

- | | |
|-------------------|----------------------|
| i) Floor moulding | ii) Bench moulding |
| iii) Pit moulding | iv) Machine moulding |

2. As per the mould materials

i) Sand Moulding

- | | |
|--------------------------------|----------------------------|
| a) Green sand moulding | b) Dry sand moulding |
| c) Loan moulding | d) Shell moulding |
| e) Cement banded sand moulding | f) Core sand moulding |
| g) Skin dried sand moulding | h) Carbon-dioxide moulding |

ii) Plaster moulding

iii) Metallic moulding

1.16.1 Floor Moulding

- When mould size is large, moulding work is carried out on foundry floor.
- This method is mainly used for medium and large sized casting.

- The mould has its drag portion in the floor itself and cope portion may be rammed in a box and inverted on the floor.
- By this method both green and dry sand mould can be made.
- In floor moulding, venting of moulds sometimes creates problem.
- Hence, a bed of coke may be laid in the bottom of the mould which is later connected to the atmosphere by using two vent pipes, erected by the sides of the mould.
- This method is used for producing parts such as wheels, pulleys, cylinder covers, ribbed plates, etc.

1.16.2 Bench Moulding

- When mould size is small and light in weight, moulding work is carried out on a bench.
- By this method, both green and dry sand mould can be made.
- Both cope and drag are rammed on the bench itself.
- Moulds for both i.e. ferrous and non ferrous casting are made on the bench mould.

1.16.3. Pit Moulding

- Casting which are so large that they cannot be made in flasks are moulded in pit dug on the floor.
- By this method, very big jobs can be handled and cast easily.
- It is called as pit moulding because the mould is prepared in a pit form.
- The mould has its drag part in the pit and a separated cope is rammed.
- The depth of drag in pit moulding is so large that the moulder can enter the drag and prepare it.
- A pit is of square or rectangular shape.
- Gates, runner pouring basin, sprue, etc. are made in the cope itself.
- Cope and drag are then assembled and sometimes a crane is used for closing the mould.
- Pit moulding can be a slow process.

1.16.4 Green Sand Moulding

- It is the most widely used moulding process.
- The green sand is used for moulding process which consists of silica sand, clay, water and other additives.
- Green sand mixture contains 10 to 15% clay binder, 3 to 6% water and remaining silica sand.
- Green sand mixture is prepared and mould is made by packing the sand around the pattern.
- Cope and drag are assembled and the molten metal is poured when the mould cavity is neither dried nor backed.

- This method is mostly preferred for making small and medium casting and suitable for non-ferrous casting.
- The parts like railing and gates, moulding boxes, grills, weights, etc. can be made by this method.

1.16.5 Dry sand moulding

- This method is almost similar to green sand moulding except that the composition of sand constituents is different in this case.
- While preparing dry sand mixture, special binding materials like resin, clay or molasses are added to give strong bond to the sand.
- Hence, the dry sand mould possesses high strength.
- Dry sand moulds are more permeable than green sand moulds.
- Casting produced by this method possesses clean and smooth surfaces.
- As compared to green sand moulding, this method produces casting with fewer defects.
- Dry sand moulding provides better overall dimensional accuracy to the moulds.
- But the main disadvantage of this method is, it requires more labour and consumes more time in completing the mould and mould baking is also an extra work.
- Due to high cost and time consuming process, it is not used in mass production.
- It is used for producing parts like larger rolls, gear housing, machinery components, etc.

1.16.6 Loam Moulding

- It is a very different method of moulding.
- In this, a rough structure of component is made by hand using bricks and loam sand.
- The sand used is known as loam sand or loam mortar.
- Then the desired shape is given to the made structure with the help of strickle and sweeps, hence pattern is not required.
- After preparing the mould, it is backed to give strength.
- This method is mostly used for producing large casting in very small numbers.
- It enables to save time, labour and material because use of pattern is avoided.
- But not used widely because, it takes time for preparing the mould and skilled moulder is required.
- It is used for producing parts like cylinders, round bottom kettles, gears, huge bells, etc.

1.17 Gating System

- Gating is the term applied to the method of forming channels in the sand through which the molten metal travels from the sprue hole to the mould and out of the mould to the riser.
- Gating system refers to all channels by means of which molten metal is delivered to the mould cavity.
- Since the way in which liquid metal enters the mould has a decided influence on the quality and soundness of a casting.
- The different passages for molten metal are carefully designed and produced.
- Figure 1.33 shows the various components of gating system which is composed of:

(a) Pouring cups and basins (b) Sprue (c) Runner (d) Gates (e) Riser, etc.

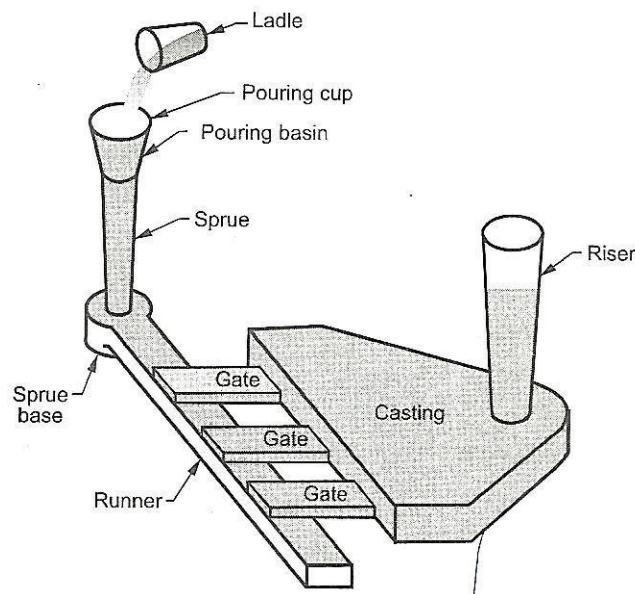

Figure 1.33 Components of Gating System

1.17.1 Pouring Cups and Basins

Pouring cups:

- A pouring cup is a funnel shaped cup which forms the top portion of the sprue.
- It makes easier for the ladle or crucible operator to direct the flow of metal from crucible to sprue.

Pouring basins:

- The molten metal is not directly poured into the mould cavity.
- It is poured into a pouring basin which acts as a reservoir from which it moves smoothly into the sprue.
- It prevents the slag from entering the mould cavity.

- It holds back the slag and dirt, which floats on the top and allows only the clean metal to enter into the sprue.
- The basin is cut in various shapes into the cope directly.

1.17.2 Sprue

- Sprue is the channel through which the molten metal is brought into the parting plane where it enters the runner and gates.
- The sprue may be square or round and is generally tapered downwards, to avoid aspiration of air and metal damage.
- Sprues upto 20 mm diameter are round in section, whereas larger sprues are generally rectangular.
- In a rectangular sprue, there is less turbulence.

1.17.3 Runner

- In large casting, molten metal is generally carried from the sprue base to several gates around the cavity through a passage called as **runner**.
- Depending upon the shape of the casting, the runner may be located in the cope or drag part.
- To avoid aspiration and turbulence, it should be streamlined.

1.17.4 Gates

- A gate is a channel which connects runner with the mould cavity, through which molten metal flows to fill the mould cavity.
- The location and size of the gates are so arranged that, they can feed liquid metal to the casting at a rate consistent with the rate of solidification.
- More than one gate is employed to feed a fast freezing casting.
- The gate should not have sharp edges as they may break during pouring and thus carried with the molten metal into the cavity.
- The gates should be located where they can be easily removed without damaging the casting.

The major types of gates are as follows:

- (a) Parting line gates (b) Top gates
- (c) Bottom gates (d) Side gates

(a) Parting line gates :

- These gates enter the mould cavity along the parting line separating the cope and drag portions of the mould. Refer Figure 1.34.
- These gates are the simplest in nature and construction.

- Such gates are commonly used and are found to give satisfactory service except when the mould is very deep.

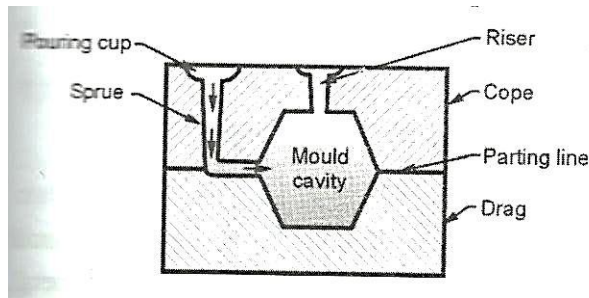

Fig. 1.34 Parting line gate

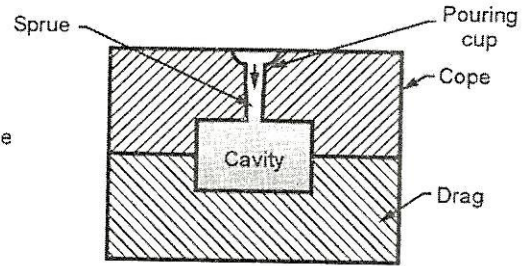

Fig. 1.35 Top gate

(b) Top gates :

- Top gate is also called as drop gate because the molten metal just drops on the sand in the bottom of the mould. Refer. Figure 1.35.
- A top gate simplifies the moulding with low consumption of additional metal.
- There is lot of turbulence in this system.
- Also, the dropping liquid metal stream erodes the mould surface.
- It is not favourable for non-ferrous casting.
- Top gates are further classified as:

Pencil gate	Edge gate	Gate with strains core
Finger gate	Ring gate	Wedge gate

(c) Bottom gates

- A bottom gate is provided in the drag half of the mould. Refer Figure 1.36.
- In this, liquid metal fills rapidly the bottom portion of the mould cavity and rises steadily and gently up the mould walls.
- Bottom gates provide less turbulence and erosion in the mould cavity.
- It is not used in large and deep casting because the metal cools gradually as it rises up.

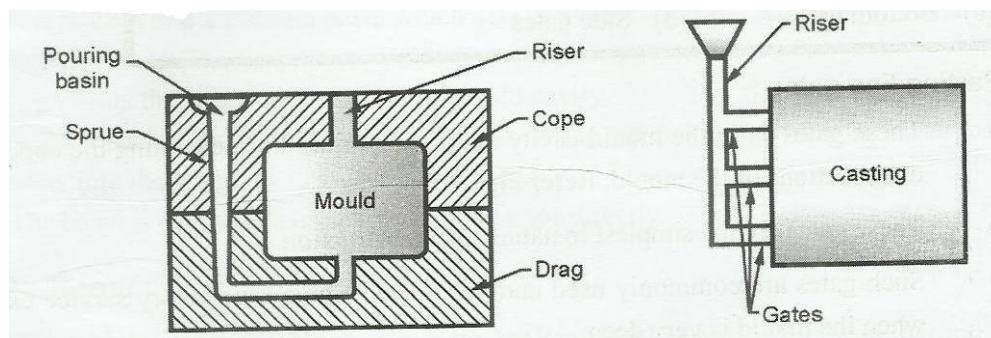

Fig. 1.36 Bottom gate

Fig. 1.37 Side gate

(d) Side gates

- Side gates are provided on either left or right side of the casting.
- Hence, the metal enters into the mould cavity from sides.
- It enters near the bottom first, and then as the level of the metal rises in the mould the incoming molten metal starts entering near the surface of the rising metal. Refer Figure 1.37.

1.17.5 Riser or Feeder Head

- A riser is a passage of sand made in the cope to permit the molten metal to rise above the highest point in the casting after the mould cavity is filled up. Refer Figure 1.33.
- This metal in the riser compensates the shrinkages as the casting solidifies. The functions of risers are as follows:
 - To feed metal to the solidifying casting, so that shrinkage cavities are got rid of.
 - It permits the escape of air and mould gases as the mould cavity is being filled with the molten metal.
 - It promotes directional solidification.
 - Also, it shows that the mould cavity has been completely filled or not.

A casting solidifying under the liquid metal pressure of the riser is comparatively sound. There are two types of risers i.e. open riser and blind riser. An open riser has its top surface exposed to atmosphere, where the blind riser is a cavity in a round shape formed either on the top or side of the casting.

1.18 Moulding Machines

Moulding machine is used for mass production. Since the hand moulding is a slow process, it can be only used for making few castings. For producing more castings, moulding is done by using moulding machines. It reduces the labours but it increases the quality of the mould.

Moulding machines will do the following operations:

1. Ramming the moulding sand
2. Rapping the pattern for easy removal
3. Removing the pattern from the sand

1. Jolting machine.
2. Squeezing machine.
3. Sand slinger.

1.18.1 Jolting Machine

In Jolting machine, the pattern is placed in the flask on the table. The flask is filled up with moulding sand. The table with flask is raised to about 80 mm and suddenly dropped. The table will be operated pneumatically or hydraulically. The sudden dropping of table from a height makes the sand pack evenly around the pattern. This type of machine is mainly used for ramming horizontal surfaces on the mould. The operation is noisy because of jolting.

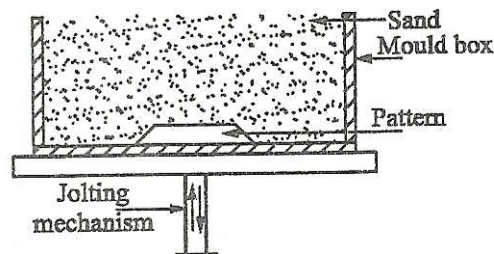

Figure 1.38 Jolt Machine

1.18.2 Squeezing Machine

In a squeezing machine, the moulding sand in the flask is squeezed between the machine table and a squeezer head. A top squeezer machine is shown in Figure 1.39. The mould board is clamped on the table. The flask is placed on the mould board. The pattern is placed inside the flask. The sand is filled up and leveled. The table is raised by the table lift mechanism against the squeezer head. The platen enters the sand frame and packs the sand tightly. After squeezing the flask, the table comes down to the starting position.

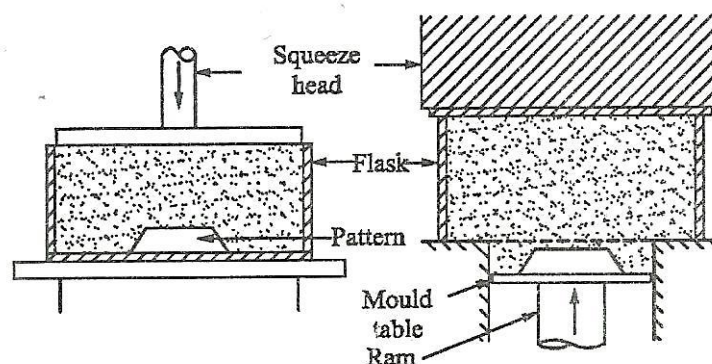

Figure 1.39 Top and Bottom Squeezing Machine

The main limitation of this machine is that the sand is rammed more densely on the top of the mould than the sand near the pattern.

1.18.3 Bottom Squeezer Machine

Here, the pattern is placed on the mould table. The mould table is clamped on the ram. The flask is placed on a frame and is filled with sand. The table with the pattern is raised up

against the squeezer head. Thus, the flask with the pattern is squeezed between the squeezer head and the table. Then the table returns to its original position.

1.18.4 Sand Slinger

Moulding process is performed by using a sand slinger, as shown in Figure 1.40. In this, the pattern is placed on a board. The flask is placed over it. Now, the slinger is operated. The slinger has an impeller which can be rotated with different speeds. When the impeller rotates, it will throw a stream of sand at greater velocity into the flask. Hence, the sand is packed in the flask.

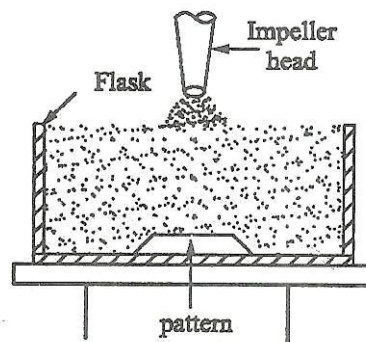

Figure 1.40 Sand Slinger

The slinger can be moved to pack the sand uniformly around the pattern. The density of sand is controlled by the speed of the impeller. In this method, the ramming will be uniform with good strength. It is used for large and medium size moulds.

1.19 Melting Furnaces

Various types of melting furnace are used in the foundry shop. The type of furnace used depends upon the type of metal and the quantity of metal to be melted. The metal melting furnaces used in foundries are:

1. Blast furnace – For smelting iron to produce pig iron
2. Cupola furnace – For cast iron
3. Open hearth furnace – For steel
4. Crucible furnace – For non-ferrous metal
 - a) Pit type furnace
 - b) Coke fired stationary furnace
 - c) Oil fired tilting furnace
5. Pot furnace
6. Electric furnace
 - a) Direct arc furnace
 - b) Indirect arc furnace
 - c) Induction furnace

1.19.1 Blast Furnace

A blast furnace shown in Figure 1.41 is a type of furnace used for smelting metal ore, usually iron ore. The combustion material and ore are supplied from the top while air flow is supplied from the bottom of the chamber, so that the chemical reaction takes place, not only at the surface throughout the ore. This type of furnace is typically used for smelting iron to produce pig iron, the raw material for wrought and cast iron.

Blast furnace is named so because very high temperature developed inside the furnace by means of forcing a blast of heated air. Its height is about 30 m and interior diameter is of 8 m.

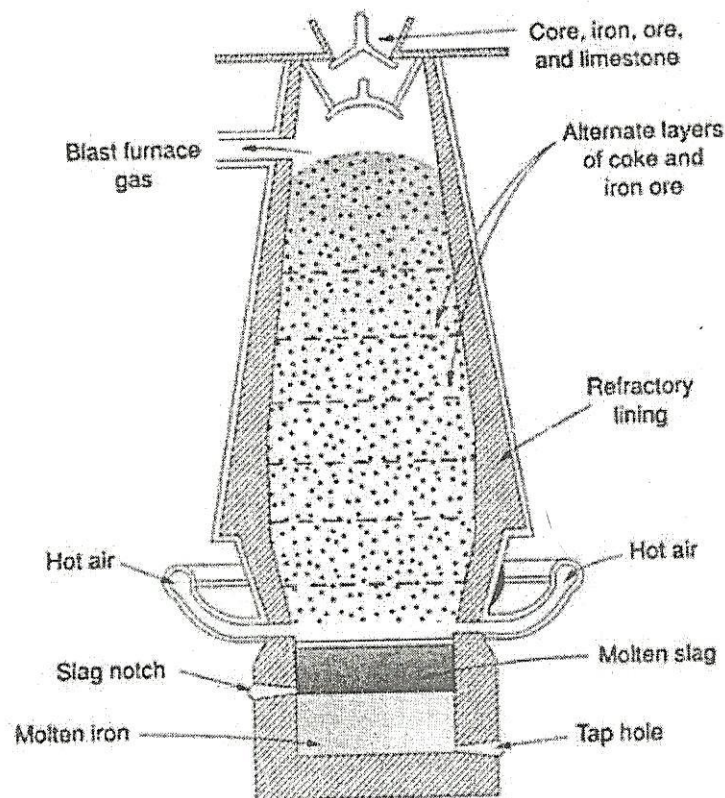
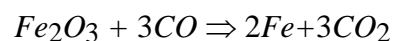

Figure 1.41 Blast Furnace

Working process

In this furnace the unwanted silicon and other impurities are lighter than the molten iron (pig iron) which is its main product. The furnace is built in the form of a tall, chimney – like structure lined with refractory bricks. Coke, limestone and iron ore (iron oxide) are poured in at the top. Air is blown in through tuyers near the base. This “blast” allows combustion of the fuel. This reduces the oxide in the metal, which is being heavier sinks into the bottom of the furnace. The nature of reaction takes place inside the furnace is;



More precisely, the compressed air blown into the furnace reacts with the carbon in the fuel to produce carbon monoxide, which then mixes with the iron oxide, reacting chemically to produce iron and carbon dioxide, which leaks out of the furnace at the top. The temperature in the furnace is typically about 1500°C, which is also enough to decompose limestone (calcium carbonate) into calcium oxide and additional carbon dioxide:

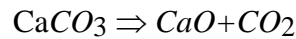

The calcium oxide reacts with various acidic impurities in the iron (notably silica), forming a slag containing calcium silicate, CaSiO_3 which floats on the iron.

The pig iron produced by the blast furnace is not very useful due to its high carbon content (around 4-5%) which makes it very brittle. It is used to make cast iron goods, often being remelted in a foundry cupola. The blast furnace remains an important part of modern production. Modern furnaces include Cowper stoves to pre-heat the blast air to high temperatures in order to avoid cooling (and the having re-heat) the mix they use fairly complex systems to extract the heat from the hot carbon dioxide when it escapes from the top of the furnace, further improving efficiency. The largest blast furnaces produce around 60,000 tonnes of the iron per week.

1.19.2 Cupola Furnace

This type of furnace is used for melting cast iron.

Construction

It is a vertical, cylindrical shell made of 10mm thick steel plate. It is lined with refractory bricks inside. Two bottom doors close the bottom of the cupola. A sand bed is laid over the bottom doors sloping towards the tap hole. Molten metal stays over this bed. The legs are set at the bottom of the furnace using a concrete. There is a tap hole for taking the molten metal. A plug made of clay closes the tap hole. The slag hole is provided in the shell above the tap hold. The slag floating over the molten metal is removed through this slag hole. The opening called tuyeres are provided one meter above the bottom. Fuel is supplied through these tuyeres for making complete combustion of fuel. There is a wind box and blower for the supply of air into the furnace. For charging the metal and fuel into the furnace, a separate charging door is made.

Preparation

The slag and waste from previous melting are cleaned. Broken bricks are repaired or replaced, if necessary. Then bottom doors are closed. A sand bed with sloping towards tap hole is prepared up to a height of 200 mm. a tap hole is formed and lined with clay. Then a slag hole is prepared. Finally, the cupola is dried thoroughly.

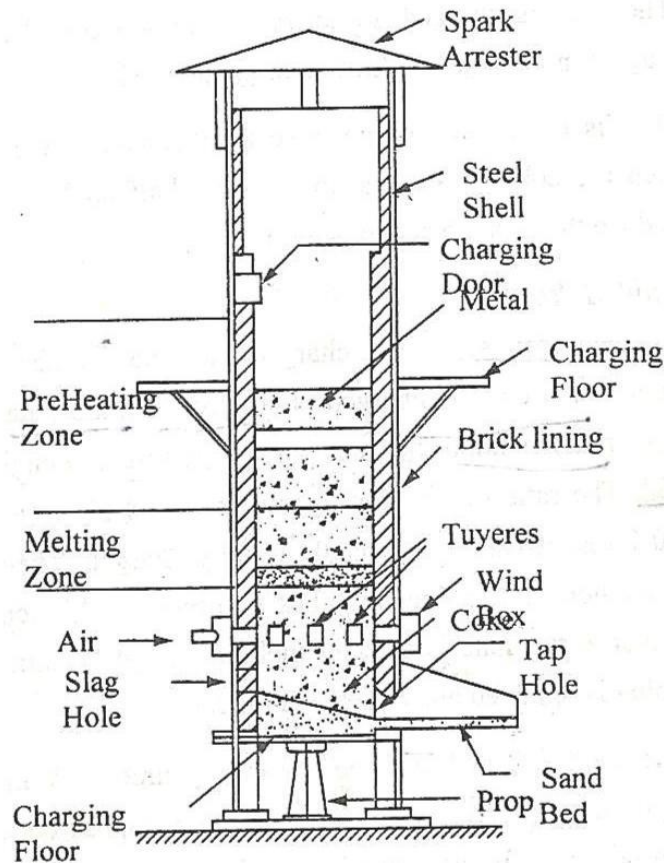

Figure 1.42 Cupola Furnace

Firing

Oil waste and wooden pieces are placed at the bottom and the fire is started. Now, the sufficient amount of air is supplied when the wood starts burning. The coke is charged at several portions. Now, the coke burns. Again and again more coke is added up to the tuyere level. The blast is turned off. Coke is again added up to the level of bed charge. Then, the coke is allowed to burn for half an hour. Finally, the charging is done through the changing door.

Charging and Melting

Pig iron and iron scrap are charged into the furnace through the charging door. Then coke is charged alternatively. Limestone is added to the charge to remove impurities and also to ensure thorough mixing of molten metal. The ration of pig iron to limestone and pig iron to coke are 25:1 and 10:1 respectively. The cupola is fully charged. Then, the iron is soaked for one hour. After that, the blast is turned on. The molten metal will begin to collect at the sand bed. After melting enough quantity of molten metal, clay plug is removed and collected in ladles.

Then the molten metal can directly be poured into moulds. The floating slag on the top layer of the molten metal is tapped out through the slag hole. Again the furnace should be charged to the full level for repeating the same procedure.

At the end, the cupola is shut off by stopping the air blast. Then, the remaining molten metal is removed, the bottom doors are opened, the wastes are dropped down and they are quenched by water.

Application

Cupola is used to melt cast iron.

Advantages

1. Initial cost is comparatively less than other type of furnaces.
2. It is simple in design.
3. It requires less floor area.
4. Operation and maintenance are simple.
5. It can be operated continuously for many hours.

1.20 PRINCIPLE OF SPECIAL CASTING PROCESSES

1.20.1 Shell Mould Casting

The shell mould casting is a semi-precise method for producing small castings in large numbers. The process involves the use of a match plate pattern similar to cope and drag patterns which are used in green sand mould casting.

Initially, the patterns are machined from copper alloys, aluminum or cast iron depending upon the lift of the pattern. They are made with usual allowances and polished surfaces. Then it is attached to the metal match plate.

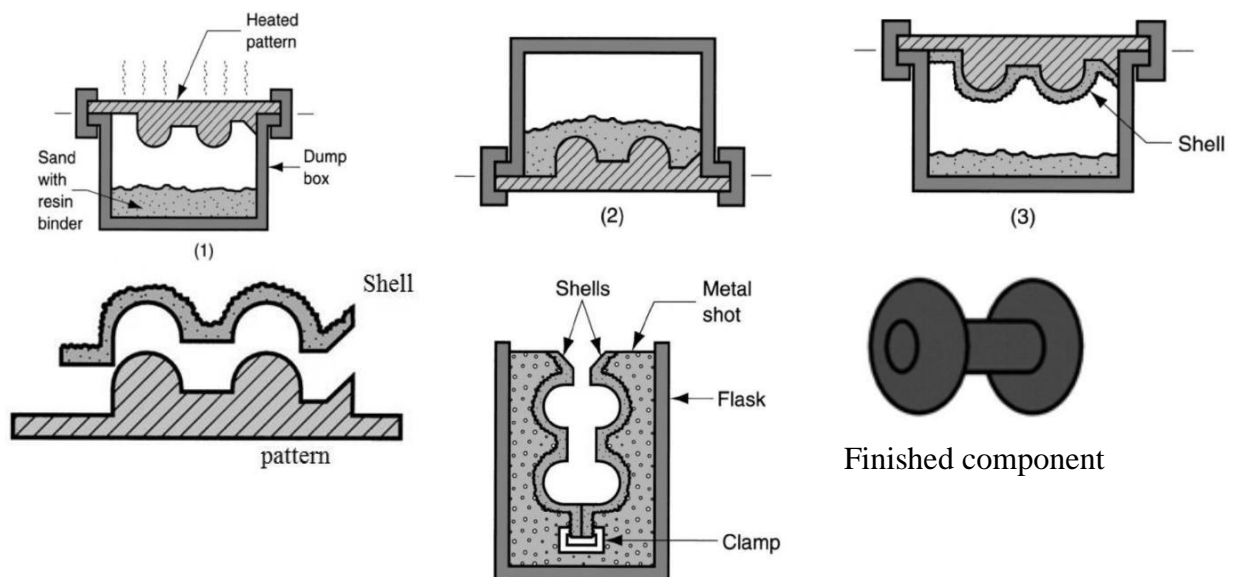

Figure 1.42 Shell Mould Casting

The mould material contains 5 to 10% of phenolic resin mixed with fine dry silica. These are mixed with either dry oil or alcohol. It should be noted that there is no water used.

The pattern is heated to about 230-600°C. Then, the sand-resin mixture is either dumped or blown over its surface. Sometimes, to prevent the sticking of sand with pattern, a release agent silicone is sprayed over the hot pattern. The heated pattern melts and hardens the resin. This results in bonding the sand grains closely together and forms a shell around the pattern. After a specified time of 20-30 sec, the pattern and sand are inverted, as shown in Figure 1.42

(2). The thickness of the shell can be accurately controlled by the time of contact of the mixture with the heated pattern. In about 20-30 sec. A normal shell thickness of 6 mm can be obtained. The extra sand which is not adhered to the shell is removed off. The thickness of the shell is depending on the required strength and rigidity to hold the weight of the liquid metal to be poured into the mould.

Then, the mould is heated in an oven at 300°C for 15-60 sec. This curing makes the shell rigid when it can be stripped off by means of ejector pins mounted on the pattern. Thus, the formed shell constitutes one-half of the mould. Two such halves, placed one over the other make the complete mould, as shown is Figure.

While pouring the molten metal, the two halves are clamped down together by clamps or springs. After cooling and solidification, the shells are broken or shaken away from the castings.

Applications

1. It is used for making brake drums and bushings.
2. Cams, cam shaft, piston and piston rings can be made.
3. It is used for making small pulleys, motor housing, fan blades etc.
4. Air compressor crankcases and cylinders, conveyor, rollers etc., can be made.

Advantages

1. A high accuracy castings with tolerances of ± 0.002 to 0.005 mm/mm is possible.
2. Good surface finish can be obtained.
3. Complex parts can be made by this method.
4. Less sand is used compared to other methods.
5. Moulds can be stored for long time.
6. Permeability of thin shell moulds is high. Therefore, defects are less. Better quality castings can be made.

Limitations

1. Only small size of the castings can be made.
2. Serious dust and fume problem during sand and resin mixing will occur.
3. The cost is more.
4. Carbon pickup may occur in the case of steels.

1.20.2 Investment Casting (or) Lost Wax Method

A wax duplicate of the desired casting is created to be invested into a “Ceramic Slurry”.

The slurry covered investment can be dipped into alternating coatings of sand and slurry until a suitable thickness of shell is achieved that can hold the molten metal after the investment is burnt out.

The “Burn-Out” process requires that the investment and coating are inverted in an oven that is fired to 1800F so that the investment can flow out and be recovered. The refractory coating is also cured in this procedure.

Once the investment is lost, and the Refractory is cured the mould is removed and poured immediately while it is still hot.

Investment casting can make use of most metals, most commonly using aluminum alloys, bronze alloys, magnesium alloys, cast iron, stainless steel, and tool steel.

This process is beneficial for casting metals with high melting temperatures that cannot be moulded in plaster or metal.

Parts that are typically made by investment casting include those with complex geometry such as turbine blades or fire arm components. High temperature applications are also common, which includes parts for the automotive, aircraft, and military industries.

Principle

Method also called as precision investment casting. The method involves the use of expendable Pattern with a shell of refractory material surrounded to form a casting mould. Since the pattern made up of wax is melted out and gets destroyed. That is why the name “Lost wax method”.

Procedure

1. Produced a master pattern

The pattern is a modified replica of the desired product made from metal, wood, plastic, or some other easily worked material.

2. From the master pattern, produce a master die

This can be made from low-melting-point metal, steel, or possibly even wood. If low-melting-point metal is used.

3. Produce wax patterns

Patterns are made by pouring molten wax into the master die, or injecting it under pressure, and allowing it to harden. Plastic and frozen mercury have also been used as pattern material.

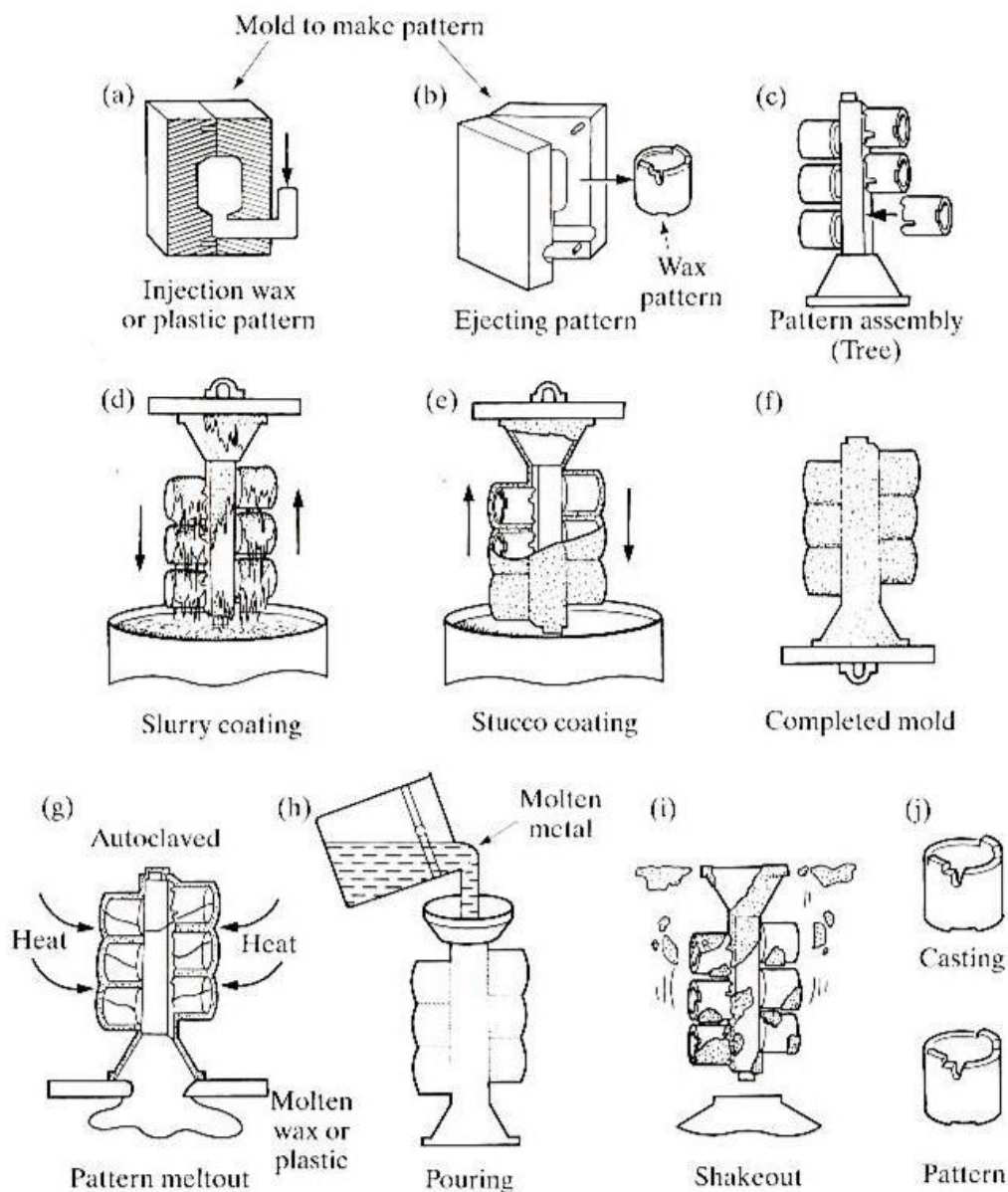

Figure 1.43 Investment Casting

Process 4. Assemble the wax patterns onto a common wax sprue

The individual wax patterns are attached to a central sprue and runner system by means of heated tools and melted wax. In some cases, several pattern pieces may first be united to form a complex.

5. Coat the cluster with a thin layer of investment material

This step is usually accomplished by dipping the cluster into a watery slurry of finely ground refractory material.

6. Produce the final investment around the coated cluster

After the initial layer is formed, the cluster can be redipped, but this time the wet ceramic is coated with a layer of sand and allowed to dry. This process can be repeated until the investment coating is the desired thickness (typically 5 to 15 mm).

7. Allow the investment to fully harden**8. Melt or dissolve the wax pattern to remove it from the mould**

This is generally accomplished by placing the moulds upside down in an oven, where the wax melts and runs out, and any residue subsequently vaporizes.

9. Preheat the mould in preparation for pouring

Heating to 550 to 1100°C (1000 to 2000°F) ensures complete removal of the mould wax, cures the mould to give added strength, and allows the molten metal to retain its heat and flow more readily into all of the thin sections.

10. Pour the molten metal

Various methods, beyond simple pouring, can be used to ensure complete filling of the mould, especially when complex, thin sections are involved.

11. Remove the casting from the mould

This is accomplished by breaking the mould away from the casting. Techniques include mechanical vibration and high-pressure water.

Advantages

1. Smoother surfaces (1500 to 2250 micro-mm root mean-square). Close tolerance (of +0.003 mm/mm)
2. High dimensional accuracy
3. Intricate shape can be cast
4. Castings do not contain any disfiguring parting line
5. Machining operation can be eliminated

Disadvantages:

1. Process is relatively slow.
2. Use of cores makes the process more difficult.
3. The process is relatively expensive than other process.
4. Pattern is expandable.
5. Size limitation of the component part to be cast. Majority of the castings produced weight less than 0.5 kg.

Applications

The products made by this process are vanes and blades for gas turbines, shuttle eyes for weaving, pawls and claws of movie cameras, wave guides for radars, bolts and triggers for fire arms, stainless steel valve bodies and impellers for turbo chargers.

While investment casting is actually a very old process and has been performed by dentists and jewelers for a number of years, it was not until the end of World War II that it attained any degree of industrial importance.

Developments and demands in the aerospace industry. Such as rocket components and jet engine turbine blades, required high-precision complex shapes from high-melting-point metals that are not readily machinable.

Investment casting offers almost unlimited freedom in both the complexity of shapes and types of materials that can be cast.

Process parameters of Investment casting**Process principle**

A refractory slurry is formed around a wax or plastic pattern and allowed to harden. The pattern is then melted but under mould is baked. The molten metal into the mould and solidifies.

Size limits

As small as (1/10) inch but usually less than 10 lb.

Thickness limits

As thickness as 0.025 inch but less than 3 inch/

Typical tolerance

- Approximately 0.005 inch.
- For the first inch and 0.002 inch for each additional inch.

Draft allowance

Not required

Surface finish

50 to 125 micron

1.20.3. Ceramic Mould Casting (or) Cope and Drag Investment Casting (or) Plaster Moulding

The ceramic mould casting used permanent patterns made of plaster, plastic, wood, metal or rubber and utilizes fine grain zircon and calcined, high-alumina mullite slurries for moulding. These slurries are comparable in composition to those used in investment castings. Like

investment moulds, ceramic moulds are expendable. However, unlike the monolithic moulds obtained in investment castings, ceramic moulds consist of a cope and a drag setup. Principle

The mould is made of plaster of paris (Gypsum or $\text{CaSO}_4 \cdot \frac{1}{2}\text{H}_2\text{O}$) with the addition of talc and Silica flour to improve strength and to control the time required for the plaster to set. These components are mixed with water and the resulting slurry is poured over the Pattern. After removing the pattern, mould is cured in an oven and it is ready to receive the molten metal.

Procedure

One of the most popular of the ceramic moulding techniques is the Shaw process. A reusable pattern is placed inside a slightly tapered flask, and a slurry like mixture of refractory aggregate, hydrolyzed ethyl silicate, alcohol, and a getting agent is poured on top.

This mixture sets to a rubbery state that permits removal of the pattern and the flask, and the mould surface is then ignited with a torch.

During “burn-off”, most of the volatiles are consumed, and a three-dimensional network of microscopic cracks (microcrazing) forms in the ceramic.

The gaps are small enough to prevent metal penetration but large enough to provide venting of air and gas (permeability) and to accommodate both the thermal expansion of the ceramic particles during the pour and the subsequent shrinkage of the solidified metal (i.e provide collapsibility).

A subsequent baking operation removes all of the remaining volatiles, making the mould hard and rigid. Before pouring, the ceramic moulds are often preheated to ensure proper filling and to control the solidification characteristics of the metal.

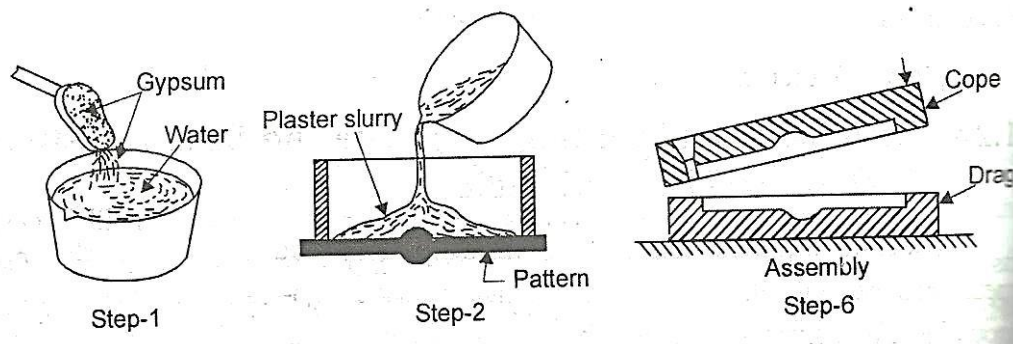

Figure 1.44 Ceramic Moulding

Advantages

1. High production rates are possible
2. High dimensional accuracy is achieved.
3. No cores are needed.

4. Complex shapes can be cast.
5. Machining can be eliminated.
6. Expensive tooling restricts the process to long run castings.
7. Long lead times are needed to develop new castings.

1.20.4. Pressure Die Casting

In the previous casting processes, expendable moulds are used where it must be broken in order to obtain the castings. In the die casting process, the mould used for making a casting is permanent, called a die. In this process, the molten metal is forced into the mould cavity under high pressure. The process is used for casting a low melting temperature material, e.g. Aluminum and Zinc alloys, brass etc. the die-casting is carried out as follows:

1. The molten metal is forced under pressure into the assembled die.
2. The die is water-cooled. So, the molten metal cools down and immediately becomes solid.
3. The die is opened. Then, the finished casting is ejected by pins.

The mould normally called die is made in two halves in which one is fixed and the other one is movable. Medium carbon and low alloy tool steel are the most common die materials. There are two types of die casting processes. They are,

1. Hot Chamber Die Casting
2. Cold Chamber Die Casting
3. Gravity Die Casting

1. Hot Chamber Die-Casting

In hot chamber die-casting, the melting furnace is an integral part of the mould. There is a gooseneck vessel which is submerged in molten metal. There is a plunger at the top of the gooseneck vessel, when the plunger is in the upward position, the molten metal flows into the vessel through a port provided on the sidewall.

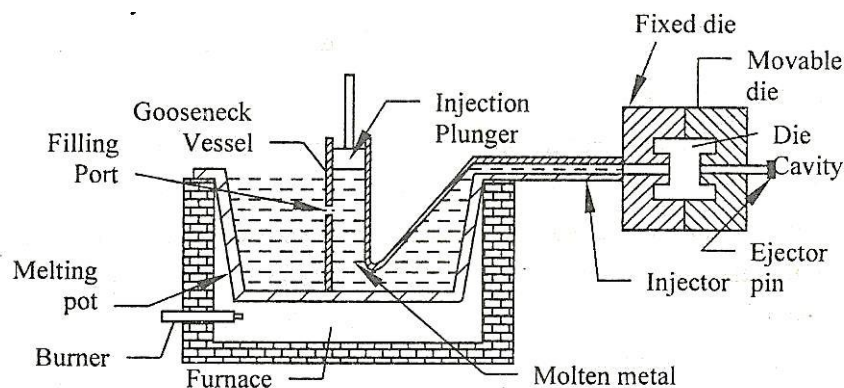

Figure 1.45 Hot Chamber Die-Casting

When the plunger comes down, the molten metal is forced into the dies. Since, the die is immediately cooled by water and sufficient cooling is provided for solidification. Then, the movable die is moved some distance and finished casting is removed by ejectors. The plunger and movable die are operated by hydraulic systems. The operating pressure of hydraulic plunger is 15MN/M^2 .

Hot chamber die-casting is suitable for casting of metals such as Zinc, tin and lead.

2. Cold Chamber Die-Casting

In cold chamber die-casting, the metal melting unit is not an integral part of the machine. The metal is melted in a separate furnace and brought to the machine for pouring. The process is shown in Figure 1.46.

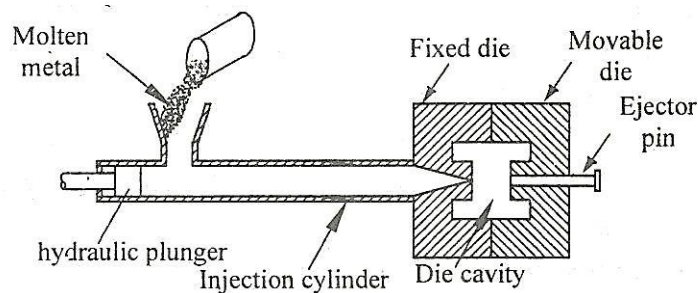

Figure 1.46 Cold Chamber Die-Casting

The machine has a cold chamber of cylindrical shape with a hydraulic plunger. A measured quantity of molten metal is poured into the injection cylinder. Then the plunger moves to the right and forces the molten metal into the die cavity. As the die is water – cooled, immediate solidification of molten metal takes place. Then the dies are separated. The finished casting is removed by an ejector pin.

Applications

1. Household equipments such as washing machine parts, vacuum cleaner body, fan case, store parts etc.
2. Automobile parts such as fuel pump, carburetor body, horn, wiper and crank case.
3. Components for telephones, television sets, speakers, microphones, record players and soon.
4. Toys, such as pistols, electric trains, model aircraft's etc.

Advantages

1. Very accurate castings can be produced with the dimensional tolerance rang of ± 0.03 to 0.25 mm.
2. Castings with very good surface finish can be made.

3. Rate of production (700 castings per hour) is high.
4. Castings with varying thickness wall can be made.
5. There is no possibility of sand inclusions.
6. Cored holes down to 0.75 mm diameter at accurate locations are possible.
7. Casting defects are less.
8. It can be stored and used for long time.
9. Die has long life. Approximately 75000 castings can be produced in a single throughout its life period.
10. The process depends on the metal to be cast.
11. The spire, runners and gates can be remelted, hence, scrap loss is less.

Limitations

1. Only small parts can be made.
2. Only non-ferrous metals can be cast.
3. Equipment cost is high.
4. It is more suitable for mass production only.

3. Gravity Die Casting

Gravity die casting is also called Permanent Mould Casting. The mould is generally made of two halves. They are hinged, at one end. These are provision for clamping them together at the other end. A permanent mould is necessary for producing large number of casting of similar shape. A permanent mould is made of heat resisting cast iron, alloy steel, graphite or other suitable material.

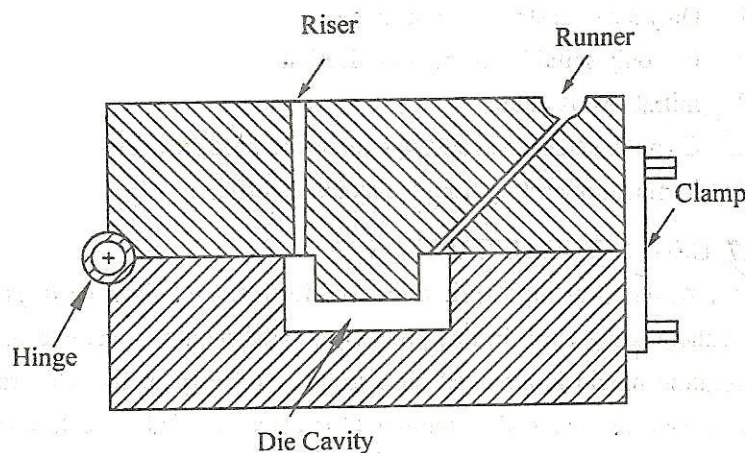

Figure 1.47 Gravity Die Casting

Pouring cup, sprue, gates and riser are made in this mould itself. First, the mould is preheated. Then refractory coating is done by spraying or brushing. This coating protects mould surfaces from erosion and sticking. Lubricated casting may also be given for easy removal or

castings. The molten metal is fed into the mould with the help of gravitational force. Hence, this process is called gravity die-casting. After the solidification, the casting is removed by opening the top die. Almost all metals can be cast in this mould. Non-ferrous materials, such as zinc, copper, aluminum, lead magnesium and tin alloys are most often cast in this method.

This method is suitable only for making components of simple shapes and design, and uniform wall thickness.

Applications

1. Accurate casting can be made.
2. It gives good surface finish to castings.
3. It is more suitable for mass production.
4. Wastage and rejection of metal is less.
5. Less floor space is enough.
6. Production rate is high.
7. Production cost is less.
8. Castings are free from defects.

Limitations

1. Only small castings can be made.
2. It is only suitable for mass production.
3. Initial cost is more.
4. Complicated shaped castings cannot be produced easily.
5. The removal of casting from the mould is difficult.

1.20.5 Centrifugal casting

Centrifugal Casting is primarily used for making hollow castings, such as pipe without using core. In this process, a metal mould is made to rotate. The rotating mould is mounted on a trolley, as shown in Figure 1.48.

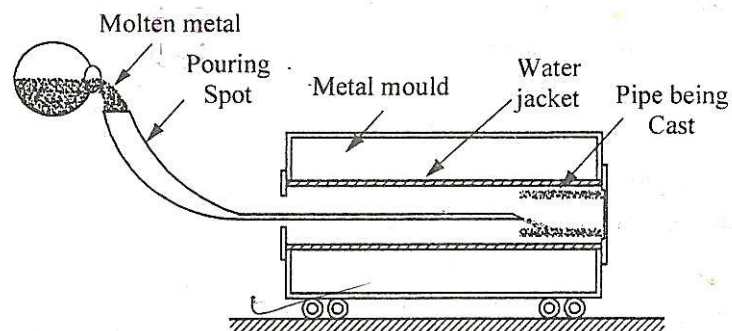

Figure 1.48 Centrifugal casting

The trolley moves over rails. The end of the mould is closed by end cores to prevent the flow of metal. The metal is poured into the mould through a long spout. The mould is rotated by electric motor or mechanical means as well as moves axially on the rails. Due to centrifugal force, the molten metal is thrown to the walls of the mould. The outside of the mould is water-cooled. So, the molten metal immediately solidifies. The centrifugal casting method is used for producing cylindrical and symmetrical objects.

Applications

Components, such as water pipes, gears, bush bearings, fly wheels, piston rings, brake drums, Gun barrels etc.

Advantages

1. Core is not required to produce hollow components.
2. Rate of production is high.
3. Pattern, runner, and riser are not required.
4. Impurities in the metal are driven out. Therefore, defects in castings are very less.
5. Thin castings can be made.
6. Castings have uniform physical properties.

Limitations

1. It is suitable only for cylindrical and symmetrical shaped castings.
2. The cost of equipment is high.

1.20.6 Carbon-dioxide Moulding

- CO₂ cores are used to make good quality castings in large numbers.
- These cores use a core material consisting of clean, dry sand mixed with a solution of sodium silicate. Generally, the mixing is done in Muller.
- The sand mixture is rammed into the core box.
- The rammed core while it is in the core box is gassed for 30 seconds at a pressure of 130 to 140 KPa with CO₂ gas. Refer Figure 1.49.
- This results in a formation of silica gel which binds sand grains into a strong, solid form.
- The main limitation of CO₂ cores is that, the used sand mixture cannot be recovered and reused.
- These cores are used in production of cast iron, steel, aluminum and copper-base alloy castings.

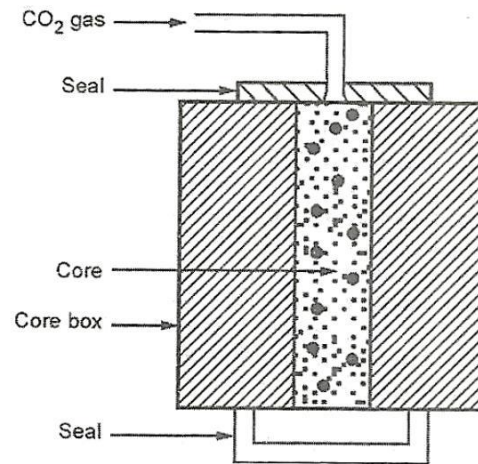

Figure 1.49 CO₂ cores

Advantages

- Baking is not required for these cores.
- These cores possess more strength and hardness.
- For this type of cores, core-dryer is not required.
- This method saves time and cost of heating.
- Semi skilled operator is required.
- For the production of cores and moulds same sand is used.
- Hollow cores can be easily made.

Disadvantages

- CO₂ cores are susceptible to moisture.
- CO₂ moulding is less suitable for non-ferrous castings and for small or thin walled castings.
- Due to inorganic nature of the bond, the sand has poor collapsibility.
- It is difficult to reclaim the used sand.

Applications

- It is used for heavy or thick walled steel castings.
- It is widely used for making larger cores for heavy ferrous castings.
- It is also used for producing cores for iron, aluminum and copper based alloy castings.

1.20.7 Stir Casting

- Conventional casting processes produce metallurgical flaws like porosity and microstructural defects.
- Hence to provide uniform microstructure and eliminate many defects, the stir casting process is used.
- Figure 1.50 shows the setup for the stir casting process.
- In this process, liquid cast metal is homogenized by vigorously stirring it with the help of a stirrer.
- Stirring helps in reducing grain size, hence the ductility and strength of the cast metal part is increased.
- Stir casting is also used in the fabrication of composite materials.
- In this, the dispersed phase such as ceramic particles or short fibers are mixed with molten matrix metal with the help of mechanical stirring.
- The liquid composite material is then cast by various casting methods.

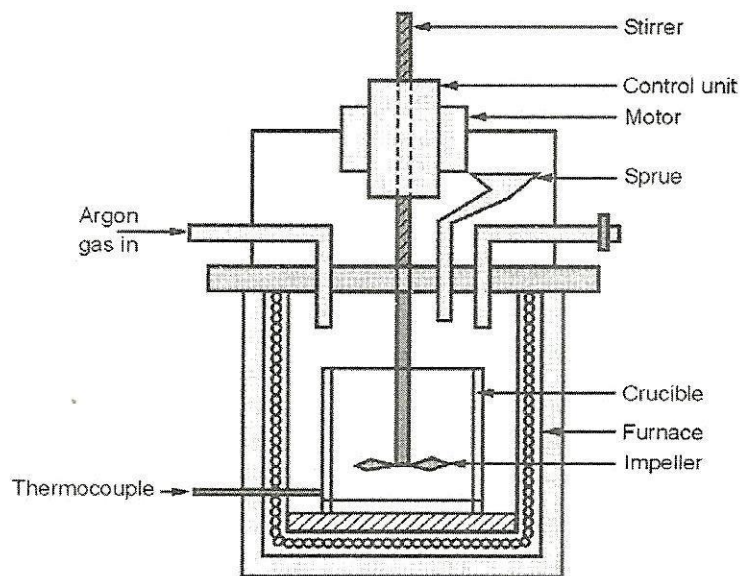

Figure 1.50 Stir Casting

Advantages

1. Casting parts free from porosity.
2. Complex shaped parts are produced neatly.
3. Excellent mechanical properties of cast component.
4. Stir casted parts have good geometrical tolerances.
5. Design of components is relatively simple and of low cost.

1.21 Cleaning of casting (Fettling)

- After solidification of casting, the moulds are broken to obtain the final casting.
- This operation is known as shake out operation, which may be performed manually or mechanically.
- The casting so obtained is not fully finished component, as it carries risers, gates, runners, etc. attached to it.
- Also, lot of sand remains adhered to its surface in the form of core.
- Hence, cleaning of casting is necessary.
- The various operations which are performed after shake out are as follows:
 - a) Removal of dry sand cores
 - b) Removal of gates, risers, runners, etc.
 - c) Removal of unwanted metal projections, fins, etc.

a) Removal of dry sand cores

- Cores can be removed by rapping action on the casting.
- For quicker removal, pneumatic rapping and hydro-blasting are also preferred.

b) Removal of gates and risers

Gates and risers attached to the casting can be removed by following methods:

- They can be broken away by hammering.
- They can be sawn by using suitable metal cutting saw.
- They can be chipped-off either by hand or by using pneumatic chipping hammers.
- They can be sheared off with the help of suitable punches mounted on punch press, called as sprue cutter.
- They can be cut off by using an oxy-acetylene flame or plasma torch.
- Sometimes, they can be removed by means of abrasive cut-off wheels.

c) Removal of unwanted metal projections and fins

The operation of removal of unwanted metal projections and fins is called as snagging.

The commonly used methods for this purpose are as follows:

- Chipping with hand or by pneumatic chisels.
- Cutting with the help of an oxy-acetylene flame.
- Sometimes, unwanted metal parts are also cut by grinding, machining or filing.



1.22 Defects in Casting:

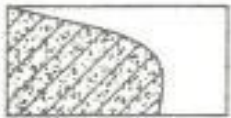
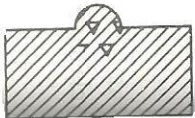
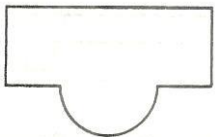

Because of some reasons, castings may have some defects. The defects in a casting may arise due to the defects in one or more of the followings:

1. Design of casting and pattern
2. Moulding and design of mould and core
3. Metal composition
4. Melting and pouring
5. Gating and risering

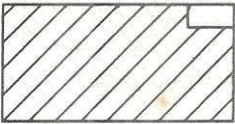
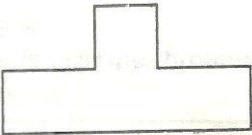
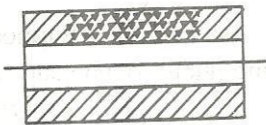
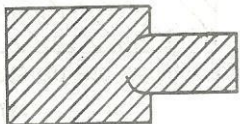
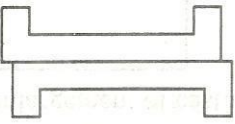
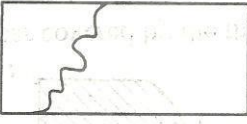
These defects may be reduced by proper control of manufacturing cycle and proper foundry techniques. The following defects are most commonly encountered in the sand mould castings.

S.No	Defects	Causes	Remedies
1	<p>Shrinkage: It is a depression on the casting surface.</p> 	<ol style="list-style-type: none"> 1. Improper solidification 2. Incorrect pouring temperature 3. Faulty gating, runner and riser system 	<ol style="list-style-type: none"> 1. Proper solidification 2. Correct pouring temperature 3. Modify gating, runner and riser system
2	<p>Blow Holes: When the molten metal is poured, gases and steam are formed. If these gases could not come out, blow holes are formed on the interior of the casting.</p> 	<ol style="list-style-type: none"> 1. Hard ramming 2. Improper venting. 3. Excess binder 	<ol style="list-style-type: none"> 1. Ram properly 2. Provides sufficient vent holes 3. Control binder content
3	<p>Scab: It is the erosion or breaking down a portion of the mould and the recess filled with metal.</p> 	<ol style="list-style-type: none"> 1. Uneven ramming 2. High velocity of pouring 	<ol style="list-style-type: none"> 1. Provide uniform ramming 2. Pour with correct velocity
4	<p>Swell: It is the enlargement of casting.</p> 	<ol style="list-style-type: none"> 1. Soft ramming 2. Quick pouring 3. Mould not properly supported 	<ol style="list-style-type: none"> 1. Ram properly 2. Pour with correct velocity 3. Provide adequate support to the mould

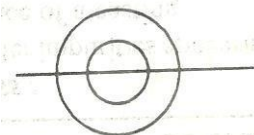
5	<p>Hard Spots: Some spots on the surface become hard</p> 	<ol style="list-style-type: none"> 1. Rapid cooling 2. Pouring at low temperature 	<ol style="list-style-type: none"> 1. Provide uniform cooling. 2. Pour at correct temperature.
6	<p>Runout: It is the leakage of metal out of the mould while pouring.</p> 	<ol style="list-style-type: none"> 1. Faulty moulding 2. Improper parting line 3. Improper gating system 	<ol style="list-style-type: none"> 1. Modify moulding system 2. Provide proper parting line 3. Provide proper gating system
7	<p>Honey Combing: Number of small cavities present on the casting surface.</p> 	<ol style="list-style-type: none"> 1. Soft ramming 2. Faulty gating 3. Faulty pouring 	<ol style="list-style-type: none"> 1. Provide correct ramming 2. Provide correct gating system 3. Pour at correct temperature
8	<p>Cracks: Small cracks appear on the corner of the casting.</p> 	<p>Due to sharp corners</p>	<p>Provide taper or round corners</p>
9	<p>Shift: Mismatching of casting sections</p> 	<ol style="list-style-type: none"> 1. Worn-out or bent clamping pins in the moulding box 2. Loose dowels in patterns 3. Misalignment of moulding boxes 4. Improper box locating of core 	<ol style="list-style-type: none"> 1. Repair or replace the pins and dowel pins in the pattern 2. Assemble the moulding boxes properly 3. Provide proper box locating of core
10	<p>Cold Shut: It is the incomplete filling of the mould cavity at one pouring</p> 	<ol style="list-style-type: none"> 1. Low pouring temperature 2. Too small gate 3. Insufficient molten metal in the ladle for one pouring 	<ol style="list-style-type: none"> 1. Pour at correct temperature 2. Provide correct gating system 3. Pour sufficient molten metal in ladle for one pouring
11	<p>Inclusions: Foreign material present in casting</p> 	<ol style="list-style-type: none"> 1. Low grade moulding sand 2. Improper skimming 	<ol style="list-style-type: none"> 1. Use correct grade of moulding sand 2. Use proper skimming for removing impurities

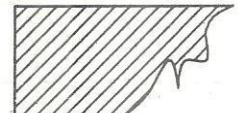
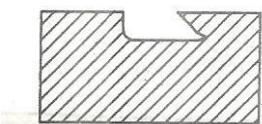
12	<p>Fins: This projection on parting line.</p> 	<ol style="list-style-type: none"> 1. Incorrect assembly of core or moulds 2. Inadequate weights 3. Improper pouring temperature 4. Improper gating system 	<ol style="list-style-type: none"> 1. Assemble the moulds and cores correctly 2. Provide enough weight in a correct place 3. Pour at correct temperature 4. Modify gating system
13	<p>Dress: Lighter impurities appearing on the top surface of a casting</p> 	Improper using of strainer and skim bob	Use strainer and skim bob properly
14	<p>Rat tail: It is a long, shallow, angular depression normally found in a thin casting.</p> 	Improper compressed layer fails by one layer instead of expanding	Provides proper expansion instead of forming compressed layer
15	<p>Blister: The scar covered by the thin layer of a metal.</p> 	<ol style="list-style-type: none"> 1. Improper pouring temperature 2. Insufficient molten metal 	<ol style="list-style-type: none"> 1. Pour at correct temperature 2. Use sufficient molten metal

PART A**UNIT I – METAL CASTING PROCESSES**

1. **State any four types of patterns.** (May 2006, 2015)

The various types of patterns which are commonly used are as follows:

- 1) Single piece or solid pattern
- 2) Two piece or split pattern
- 3) Loose piece pattern
- 4) Cope and drag pattern
- 5) Gated pattern

2. **What are chaplets?** (May 2016)

Chaplets are supports that are provided with cores which are slender or too long to be properly supported in core prints.

3. **Define casting.** (May 2014)

Casting is the process of forming objects by putting molten metal in moulds and letting it solidify.

4. **Mention any two advantages and disadvantages of die casting.** (May 2006)

Advantages:

- It is a very fast process.
- Moulds have longer life.
- Better surface can be obtained.

Limitations:

- Moulds are much costlier.
- This method is not suitable for small quantity production.
- Shape and weight of the casting is limited.

5. **Write the requirements of good pattern.** (May 2007)

- Simple in design
- Cheap and readily available
- Light in mass
- Surface is smooth
- Have high strength

6. **Name the alloys which are generally die cast. Why are aluminium alloys preferably cast in cold chamber die casting machines?** (Nov 2016)

The main die casting alloys are: zinc, aluminium, magnesium, copper, lead, and tin; although uncommon, ferrous die casting is also possible. Metals like Zinc, tin and lead alloys are casted in hot chamber die casting having melting point below 390°C. Aluminum dissolves ferrous parts in the die chamber and hence preferred to be used in cold chamber die casting.

7. **What are the characteristics of a core?** (Nov 2016)

- It should have sufficient strength to support itself without breaking
- It should have high permeability and high refractories.
- It should have smooth surface to ensure a smooth casting.
- It should have high collapsibility, to assist the free contraction of the solidifying metal.
- It should have those ingredients which does not generate mould gases.

- 8. What is core venting? (May 2007)**
While pouring the mould with molten metal mould walls and cores heat up rapidly and releases large amount of gases. In order to prevent casting defects these gases must be vented out. For this purpose core venting are used. Core venting is incorporated in the core box itself.
- 9. What function of core? (May 2008)**
Functions of core are:
- Core provides a means of forming the main internal cavity for hollow casting.
 - Core provides external undercut feature.
 - Cores can be inserted to obtain deep recesses in the casting.
 - Cores can be used to increase the strength of the mould.
- 10. Which process is called lost waxing method? Why? (May 2008)**
Ans: Investment casting process is also known as **Lost-wax** process. The term investment refers to a clock or special covering apparel. In investment casting, the clock is a refractory mould which surrounds the precoated wax pattern.
- 11. What is the function of core print? (Dec 2008, 2012, May 2015)**
- Core prints are basically extra projections provided on the pattern.
 - They form core seats in the mould when pattern is embedded in the sand for mould making.
 - Core seats are provided to support all the types of cores.
 - Though the core prints are the part of pattern, they do not appear on the cast part.
- 12. What are the advantages and applications of ceramic moulds? (Dec 2008)**
Advantages:
- It is less expensive
 - Intricate objects can be casted.
 - Castings of thin sections and which do not require machining can be produced.
- Applications:**
- It is mainly used for all material using better ingredient in slurry.
- 13. What are the pattern materials? (Dec 2008)**
- | | | | |
|------------|----------|------------|--|
| 1) Wood | 2) Metal | 3) Plastic | |
| 4) Plaster | 5) Wax | | |
- 14. Explain the term fettling. (Dec 2009)**
Fettling is the name given to cover all those operations which help the casting to give a good appearance. It includes the removal of cores, sand, gates, risers, runners and other unwanted projections from the casting.
- 15. Name the steps involved in making a casting.**
Steps involved in making a casting are
- | | | |
|--------------------|---------------------------------|----------------|
| (1) Pattern making | (2) Sand mixing and preparation | |
| (3) Core making | (4) Melting | |
| (5) Pouring | (6) Finishing | |
| (7) Testing | (8) Heat treatment | (9) Re-testing |

- 16. What are the applications of casting? (Nov 2014)**
- Transportation vehicles (in automobile engine and tractors)
 - Machine tool structures
 - Turbine vanes and power generators
 - Mill housing
 - Pump filter and valve
- 17. Define pattern. (May 2014)**
A pattern is defined as a model or replica of the object to be cast. A pattern exactly resembles the casting to be made except for the various allowances.
- 18. List the allowances of pattern.**
The following allowances are provided on the pattern :
- Shrinkage or contraction allowance
 - Machining allowance
 - Draft or taper allowance
 - Distortion allowance
 - Rapping or shake allowance
- 19. What are the factors on which amount of machining depends?**
Factors affecting machining are
- (1) Metal of casting
 - (2) Machining method used
 - (3) Casting method used
 - (4) Shape and size of the casting
 - (5) Amount of finish required on the machined portion
- 20. Why is a taper allowance used ?**
Draft allowance or taper allowance is given to all vertical faces of a pattern for their easy removal from sand without damaging the mould.
- 21. What is meant by grain fineness number? (Nov 2014)**
A.F.S number is a number proposed by American Foundrymen's Society as a measure of the sand texture. Sands are classified into coarse, medium or fine depending on the cumulative percentage of sand retained on a set of sieves and pan of a sifter.
- 22. How do you eliminate warpage ?**
To eliminate this defect, an opposite distortion is provided on the pattern, so that the effect is balanced and correct shape of the casting is produced
- 23. Write the significance of loose moulding.**
Some patterns embedded in the moulding sand cannot be withdrawn, hence such patterns are made with one or more loose pieces for their easy removal from the moulding box.
- 24. What are the types of moulding sand?**
All types of sands used in the foundry can be grouped as:
1. Natural sand
 2. Synthetic sand
 3. Special sands
- 25. Why is synthetic sand better than natural sand?**
- (1) It requires less proportion of binder.
 - (2) Higher refractoriness and permeability.
 - (3) Properties can be easily controlled.
 - (4) Refractory grain size is more uniform.

26. Name the different types of special sand.

- (1) Green sand (2) Loam sand (3) Core sand
 (4) Parting sand (5) Facing sand (6) Backing sand

27. Define permeability.

The sand must be porous to allow the gases and steam generated within the moulds to be removed freely. This property of sand is known as permeability or porosity.

28. Define Muller.

It is a mechanical mixer used for mixing sand ingredients in dry state.

29. Name various methods of sand testing.

- (1) Moisture content test (2) Clay content test
 (3) Permeability test (4) Grain fineness test

30. Name the factors affecting permeability test

- Grain shape and size
- Grain distribution
- Binder and its contents
- Water amount in the moulding sand
- Degree of ramming

31. Define mould and loam moulding.

When the pattern is removed, a cavity corresponding to the shape of the pattern remains in the sand which is known as mould or mould cavity. In this, a rough structure of component is made by hand using bricks and loam sand. The sand used is known as loam sand or loam mortar.

32. Explain in short shell moulding.

Shell moulding is suitable for thin walled articles.

It consists of making a mould that has two or more thin shell like parts consisting of thermosetting resin bonded sand.

33. Functions of moulding machine.

- i. Ramming of moulding sand.
- ii. Rolling over or inverting the mould through 180°
- iii. Rapping of pattern.
- iv. Removing the pattern from the mould.

34. Name defects occurring in casting.**(Nov 2013)**

- (1) Blow holes (2) Porosity (3) Shrinkage
 (4) Inclusions (5) Hot tears or hot cracks
 (6) Misrun and cold shuts

35. Name the inspection methods of casting .

- (1) Pressure test (2) Magnetic particle test
 (3) Dye penetrant test (4) Radiographic inspection
 (5) Ultrasonic inspection (6) Visual inspection

PART B**UNIT I - METAL CASTING PROCESSES**

1. (i) What are the pattern making allowances and briefly explain them.
(May 2006, 2009, 2010, 2013, Nov 2012)
(ii) Describe the centrifugal casting process and applications. (Nov 2016, May 2015)
2. How are patterns classified? Describe any two types with sketches and state the uses of each of them. (Nov 2016)
3. (i) Discuss the necessity of various pattern allowances with a neat sketch. (May 2007)
(ii) Explain the properties (or characteristics) of moulding sand.
(May 2008, 2015, Nov 2016, 2012, 2014)
4. Explain in detail the working principle of the following: (May 2007)
 - (i) Investment casting (May 2010, 2013)
 - (ii) Centrifugal casting (Nov 2013)
 - (iii) Lost wax casting (Nov 2013)
5. (i) List any five casting defects, their causes and remedies
(Nov 2016, May 2006, 2008, 2010, 2014, 2015, Nov 2012, 2013)
(ii) How green sand mould is prepared? (Nov 2008, May 2015)
6. Explain the procedure for following moulding process
 - (i) CO₂ moulding (May 2013)
 - (ii) Shell moulding (May 2008, Nov 2008, 2012, 2013)
7. (i) Give the sequence of step in die casting of a part in hot chamber process.
(Nov 2008, May 2014, 2016)
(ii) Brief the different methods for inspection of casting. (Nov 2008, May 2010)
8. Describe the operation of a cupola furnace for melting cast iron. (Nov 2009, 2014)
9. A casting is required to have the following composition: C-3.25%, Si-1.8%, Mn-0.6%, P-0.5% and S-0.1%. Determine the weight of pig iron from pile A and pile B to be picked up in each metal charge if the charge (200 kg) is to contain pig iron-50%, foundry return-40% and purchased scrap-10%. Analysis of these metals is as follows:

Metal	Si%	Mn%	S%	P%
Pig iron (pile A)	2.4	0.9	0.05	0.4
Pig iron (pile B)	1.4	0.95	0.05	0.35
Foundry returns	1.7	0.6	0.06	0.3
Purchased scrap	2.2	0.7	0.07	0.25