

**TYPES OF DC MOTOR:**

1. Separately excited DC motor
2. Self-excited dc motor

- Series motor
- Shunt motor
- Compound motor
  1. Long shunt compound motor
  2. Short shunt compound motor

**SEPARATELY EXCITED DC MOTOR:**

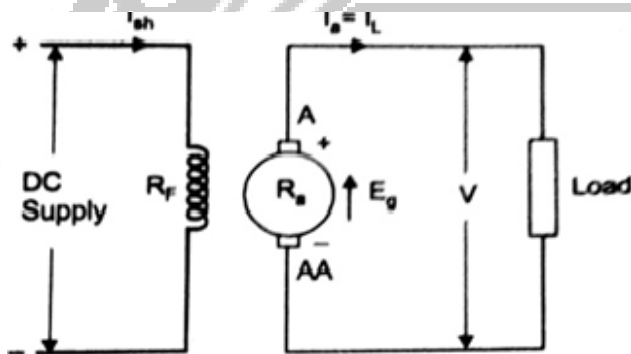

- Field winding and armature are separated.
- Field winding is excited by a separate DC source—separately excited dc motor.
- $I_a = I_L$
- $E_b = V - I_a R_a - V_{brush}$

**DC SERIES MOTOR:**

- Field winding is connected in series with armature.
- Less number of turns.
- $R_{se}$ —resistance of series field winding—small.
- $I = \text{line current}$
- $I_a = \text{series field}$
- $V = E_b + I_a R_a + I_{sc} R_{sc} + V_{brush}$ .
- $V = E_b + (R_a + R_{se}) I$ .
- $\Phi \propto I_{se} \propto I_a$

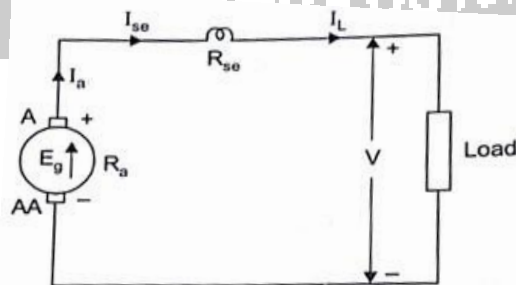

**DC SHUNT MOTOR:**

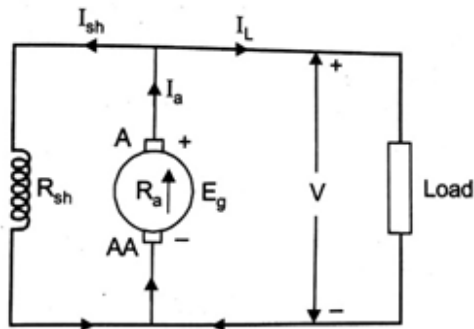

- Field winding is connected across the armature.
- More number of turns with less cross-sectional area.
- Rsh is the shunt field winding
- Ra is the armature resistance.
- Ra is small, Rsh is large.
- Voltage  $v$  = voltage across the armature and field winding.
- $I_L$  is the line current, divided into two paths
  1. Field winding
  2. Armature winding
- $I_L = I_a + I_{sh}$
- $I_a$  = armature current
- $I_{sh}$  = shunt field current
- $I_{sh} = V/R_{sh}$
- $V = E_b + I_a R_a + V_{brush}$
- $\Phi \propto I_{sh}$
- Input is constant, so flux is constant.
- Also known as constant flux motor.

**DC COMPOUND MOTOR:**

**1. LONGSHUNT:**

- Shunt field winding is connected to both the armature and the field winding.
- $I_L = I_{sc} + I_{sh}$
- $I_{se} = I_a$
- $I_L = I_a + I_{sh}$
- $I_{sh} = V/R_{sh}$
- Voltage equation  $V = E_b + I_a(R_a + R_{se}) + V_{brush}$

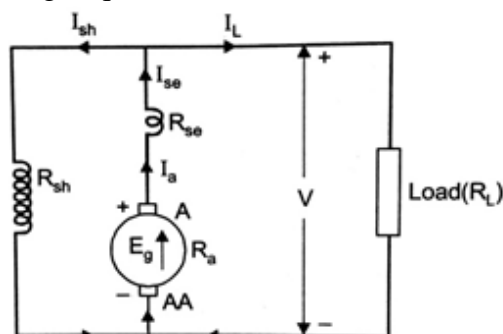

2. SHORTSHUNT:

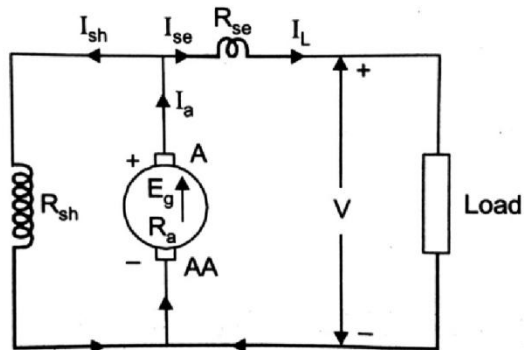

- Shunt field winding is connected across armature and series field winding is connected in series.
- $I_L = I_{se}$
- $I_L = I_a + I_{sh}$
- $I_L = I_{se} = I_a + I_{sh}$
- Voltage drop =  $v - I I R_{se}$
- $V = E_b + I_a R_a + V_{brush}$
- $I_{sh} = \frac{V - I I R_{se}}{R_{sh}}$

OBSERVE OPTIMIZE OUTSPREAD