

Chapter 1

STEAM BOILERS AND STEAM TURBINES

1.1 INTRODUCTION

The function of a boiler is to evaporate water into steam at a pressure higher than the atmospheric pressure. Water free from impurities such as dissolved salts, gases and nonsoluble solids should be supplied to boilers. This is done by suitable water treatment. Steam is useful for running steam turbines in electrical power stations, ships and steam engines in railway locomotives. It is also useful for many other industrial applications. Boiler furnace can use either solid, liquid or gaseous fuel. Boilers are mainly classified as fire-tube boilers and water-tube boilers. In the fire-tube boilers, hot gases from the furnace pass through the tubes which are surrounded by water. In the water-tube boilers, the water circulates inside the tubes which are heated from outside by the hot gases from the furnace.

A steam turbine is a prime mover in which rotary motion is obtained by the gradual change of momentum of the steam. Steam turbines are primarily used to run alternators or generators in thermal power plants. It is also used to rotate the propeller of ships through reduction gearing. The design and manufacture of turbine blades are quite complicated due to which there are only a limited number of manufacturers of steam turbines.

1.2 FORMATION OF STEAM

Let us take 1 kg of water and heat at standard atmospheric pressure. Please refer to Fig. 1.1.

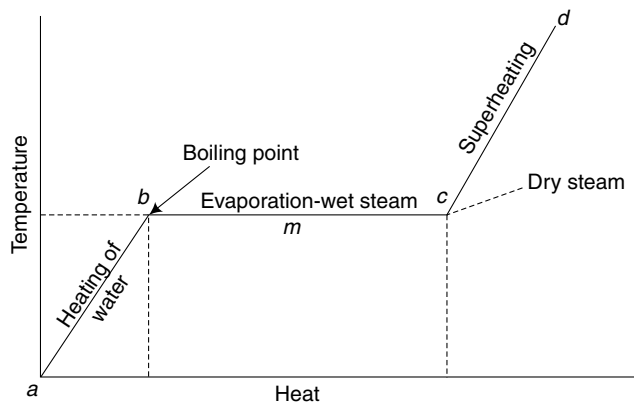

Fig 1.1 *Formation of steam*

The temperature of water is raised to its boiling point.

Boiling point of water At standard atmospheric pressure, the temperature is 100°C . It increases with pressure. The value can be obtained from steam tables. At 10 bar, the boiling point is 179.9°C .

Evaporation of water The temperature remains constant. There will be mixture of water and steam till the point C. At the mid point m , only 0.5 kg of water would have been evaporated. Here, the dryness fraction of steam is 0.5.

All the water is evaporated and the steam is said to be dry at the point C. The dryness fraction becomes 1.

Superheating The temperature is raised. In steam power plants, only superheated steam is used to run the turbines. Wet steam can be used for many industrial applications.

1.3 COCHRAN BOILER

This is a vertical fire-tube boiler as given in Fig. 1.2. The fuel is fed into the grate through the fuel door and lighted. The fuel is burnt in the grate and hot gases go to the combustion chamber through a short flue tube. The combustion continues in the combustion chamber. The fire brick

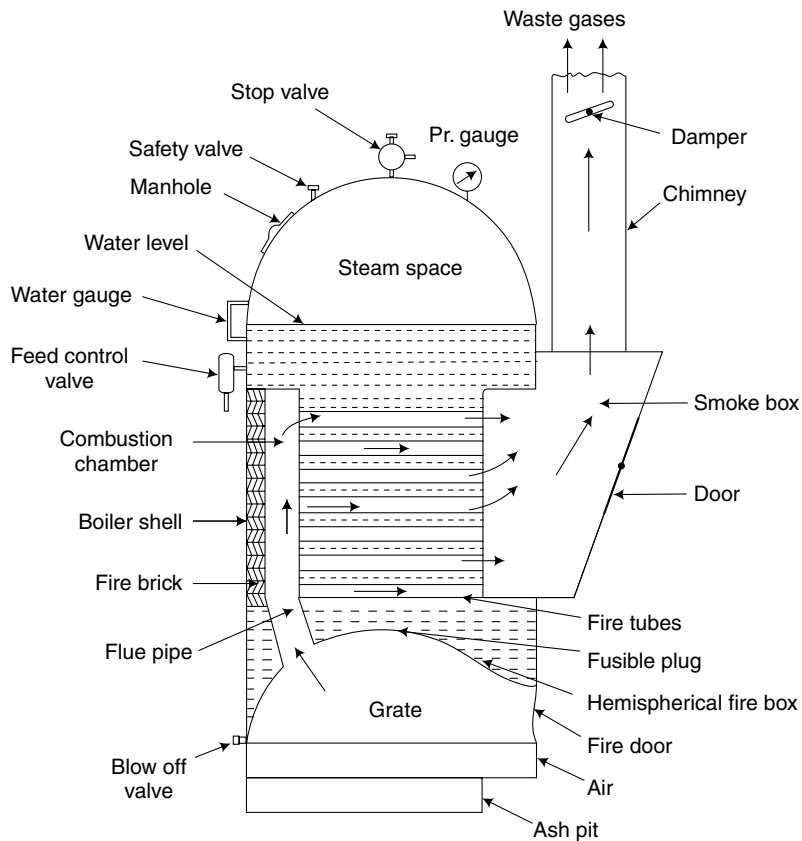

Fig. 1.2 Cochran boiler

layer prevents the over-heating of the boiler shell. The hot gases pass through a large number of fire tubes and heat the surrounding water and convert it into steam. Since the steam is lighter, it goes up to the steam space. The fire tubes normally have 62.5 mm external diameter and are 165 in number. The crown of the boiler shell and grate are both hemispherical in shape. This boiler can evaporate upto 3800 kg of steam per hour, when the diameter is 3 m and the height is 6 m.

The waste gases enter the smoke box and are released through the chimney. The amount of waste gases leaving the chimney is controlled by means of a damper manually. When the damper is partly closed, amount of waste gases leaving the chimney will be reduced. Due to this action of the damper, the amount of air entering the grate will also be reduced and, obviously, only limited fuel can be burnt and the amount of steam generated also will be reduced. Thus, we find that the damper controls the rate of steam generated. Through the manhole, the boiler attender can enter inside the boiler shell for cleaning. By opening the door in the smoke box, the fire tubes and the smoke box can be cleaned with a wire brush.

The diameter of the boilers varies from 1–3 m. The height of the boiler varies from 2–6 m. The evaporative capacity of the boiler ranges from 20–3000 kg/h. The boiler is fitted with various mountings as detailed in the following section.

1.4 BOILER MOUNTINGS

1.4.1 Water Gauge

This indicates the level of water inside the boiler. For small-capacity boilers, this is made with a thick glass tube with necessary protection and safety devices. By automatic control using float mechanism, the water level will be kept constant, with the help of a feed pump or a water injector. According to boiler regulations, *two water gauges should be fitted* in each boiler.

In case the gauge glass breaks, the rush of water and steam will carry the *ball valves* to the position shown by dotted lines and prevent water or steam coming out of the boiler shell, as shown in Fig. 1.2(a).

1.4.2 Pressure Gauge

This is to indicate the pressure of steam inside the boiler. At atmospheric pressure, the gauge will read zero. Periodically, the pressure gauge should be tested with a standard gauge and *calibrated* if necessary.

Refer to Fig. 1.2(b). The flange will be fixed on the boiler shell or drum and connected to the steam pressure. Depending upon the pressure, the *spring tube will deflect*. This deflection will be *magnified* to the pointer through the link mechanism consisting of rod, toothed sector and pinion. The U-tube will be filled with water.

1.4.3 Safety Valve

This valve is *designed to open and let some steam out when the pressure exceeds the safe designed value*. In each boiler, there should be a *minimum of two safety valves*, as per the boiler regulations.

There are two types of safety valves. One is called *lever safety valve*. The other type is the *spring safety valve*, as shown in Fig. 1.2(c). In this valve, both the valves are kept closed by the spring. Pressure of the steam will be acting on the valve through the valve chest. If the pressure exceeds the designed value, the spring will be pushed up opening the valves and letting the steam out.

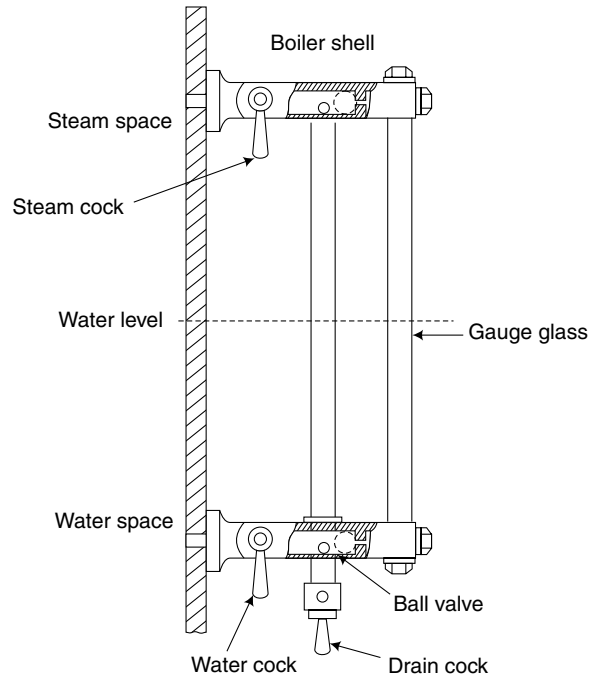

Fig. 1.2 (a) *Water-level indicator*

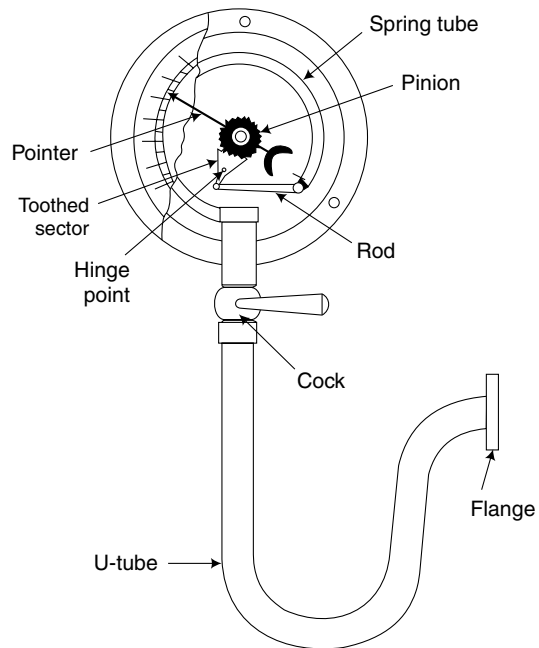

Fig. 1.2 (b) *Pressure gauge*

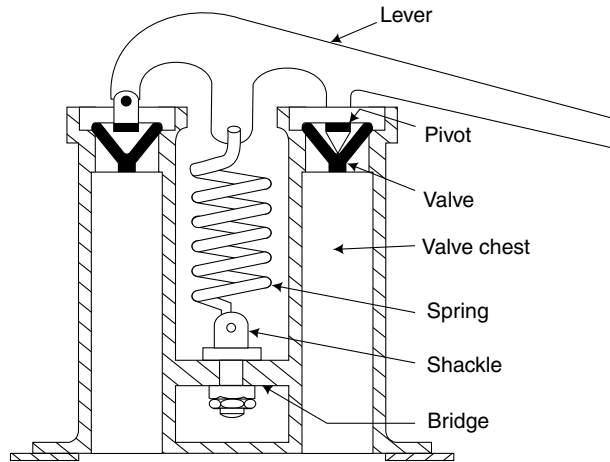

Fig. 1.2 (c) *Ramsbottom safety valve*

1.4.4 Main Steam Valve

This is to regulate or stop the flow of steam going out of the boiler to the turbine, engine, or process work.

1.4.5 Blow-off Valve

This valve is fitted at the lowest level of water. This helps to remove the salt deposits and other impurities accumulated in the bottom portion of the boiler shell or drum. This valve should be periodically opened keeping the steam under low pressure of about 2 bar.

1.4.6 Fusible Plug

This is one of the safety devices in many boilers. This prevents overheating of the fire box and other parts of the boiler. In case, the water level becomes too low due to the failure of the automatic control, the plug will melt and create an opening through which water and steam will be allowed to put out the fire in the grate. The plug is made of a special alloy which has a comparatively low melting point. The fusible plug is shown in Fig. 1.2(d).

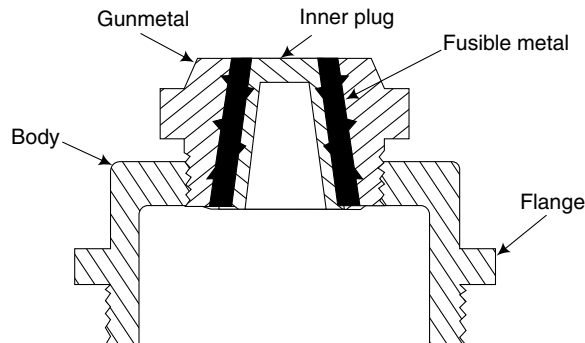

Fig. 1.2 (d) *Fusible plug*

1.5 LOCOMOTIVE BOILER

It is a horizontal fire-tube boiler. It is mostly used for railways. It consists of a shell or barrel having 1.5-m diameter and 4-m length. Fuel is fed into the fire box through the fuel door. Air enters through the damper and the slots in the grate plate. The rate of combustion and the amount of steam generated is controlled by the dampers. The fire brick arch deflects the hot gases and improves the combustion efficiency.

The hot gases pass through large number of fire tubes and enter the smoke box. The circulation of air and hot gases is improved by means of induced draft produced in the smoke box. Waste steam from the engine enters the smoke box through the blast pipe and expands. Due to the expansion, it produces a partial vacuum which improves the movement of hot gases and air. Waste gases go out through a short chimney. A door is provided in the smoke box for inspection and cleaning.

To remove the moisture from the wet steam and to increase the temperature of steam, it is superheated as shown as Fig. 1.4. The wet steam through the regulator enters the wet steam header and passes through large number of superheated tubes and finally comes to the superheater header. Then, the superheated steam goes to the engine. To accommodate the superheater tubes, some of the fire tubes are larger in diameter. There are about 157 fire tubes of 47.5 mm diameter and 24 fire tubes of 130 mm diameter. By superheating, the heat energy per unit mass of steam is increased and the thermal efficiency of the steam plant is considerably increased.

The boiler is fitted with a water gauge, a pressure gauge, a steam regulator, a safety valve, a whistle, and a fusible plug as shown in the sketch. In a locomotive boiler, the water gauge and pressure gauge will be mounted in the driver's cabin. The steam regulator can be operated by the driver from the cabin by a hand wheel. It should be noted that in railways, the use of steam engine is being reduced gradually and it is replaced by electric and diesel engines which have many advantages.

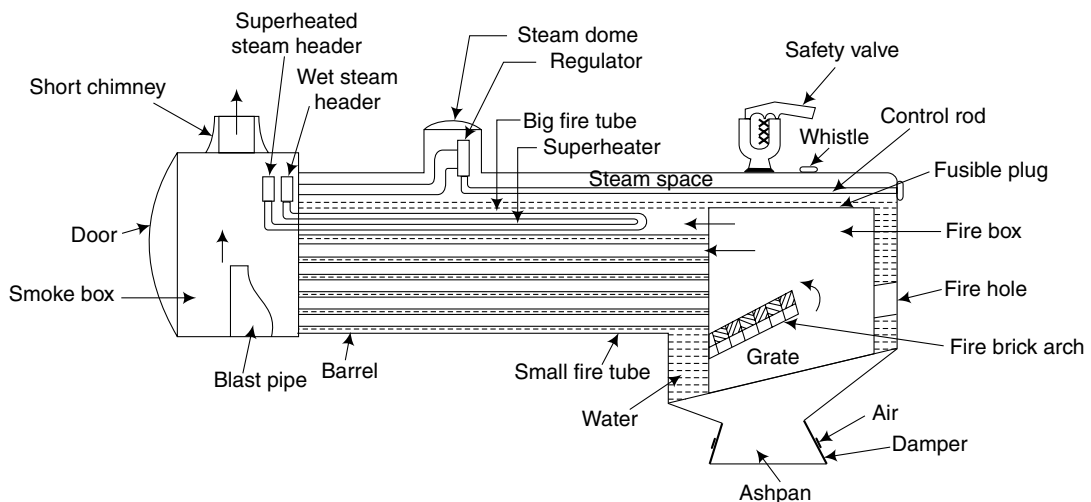

Fig. 1.4 Locomotive boiler

1.6 BABCOCK AND WILCOX BOILER

This is a water-tube boiler. It consists of a steam-water drum mounted on fire brick work. Hot gases from the furnace pass through a zigzag path through the fire brick baffles before going to the chimney through the damper. The damper controls the rate of burning and thereby the steam generation. The damper is operated by a chain passing through a set of pulleys. Water from the steam-water drum comes down to the downtake header and then goes to the uptake header through a large number of water tubes, inclined at about 14° for better circulation as shown in Fig. 1.5. It should be noted that there are many different types of Babcock and Wilcox boilers. One of the simpler types is shown in the sketch which is used for medium pressure and capacity.

The wet steam comes to the wet steam header through an antipriming pipe. The antipriming pipe removes some moisture from the steam. Then, it passes through a large number of superheater tubes and reaches the superheater header. From the superheated header, it goes to the main steam valve and finally to the steam turbine.

At the end of the downtake header, a mud drum is connected from where impurities can be removed. As shown in the sketch, the boiler is provided with two inspection doors and other mountings such as the water gauge, the pressure gauge and the safety valve.

Normally, the furnace is provided with a moving grate. In a boiler provided with a moving grate, the rate of fuel burning can easily be controlled by changing the thickness of the fuel bed and also by changing the speed of the moving grate, otherwise called chain grate. Compared to a fire-tube boiler; the evaporative capacity, the pressure of steam and the thermal efficiency of this boiler will be higher.

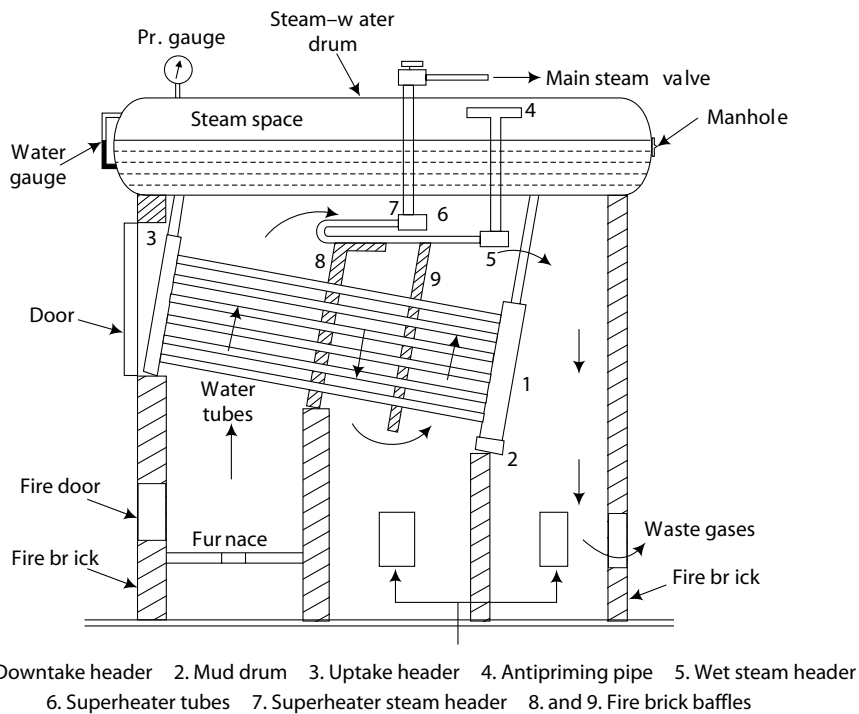

Fig. 1.5 Babcock and Wilcox boiler

1.7 LAMONT BOILER

This is one of the *high-pressure water-tube boilers working on forced circulation*. The circulation is maintained by a *centrifugal pump driven by a steam turbine using steam from the boiler*. Due to forced circulation, the rate of heat transfer and the evaporative capacity of the boiler are increased. This boiler is highly suitable for a power plant and this has a high thermal efficiency. Normally, in high-pressure boilers, either furnace oil or solid fuel in a pulverised form is used in the furnace. This boiler can produce steam upto a pressure of 150 atmosphere.

A simple layout sketch is given in Fig. 1.6. Water is circulated through the evaporator tubes. Hot gases from the furnace or the combustion chamber heat the water and evaporate into steam. Wet steam will come to the steam space in the steam-water drum. In the superheated tubes, the moisture from the wet steam is removed and also the temperature is raised considerably. In the economiser, the feed water is heated by means of waste gases before going to the chimney. Due to the feed water heating, thermal stress is reduced in various parts of the boiler. If any part is subjected to a large temperature difference suddenly, thermal stress will be induced in the part resulting in failure due to the development of cracks. Due to the use of heat in the waste gases, the thermal efficiency is further increased.

Due to high pressure of steam, the temperature of steam is increased. So the temperature of the furnace should also be increased by pre-heating the air. The method of pre-heating the air is shown in the sketch. The thickness of the drum and pipes should be more due to high pressure. In the boiler, bent tubes made of high quality steel are used. In the furnace, wall pipes are used to increase the capacity of the boiler and also to cool the furnace wall. This boiler is fitted with usual mountings such as

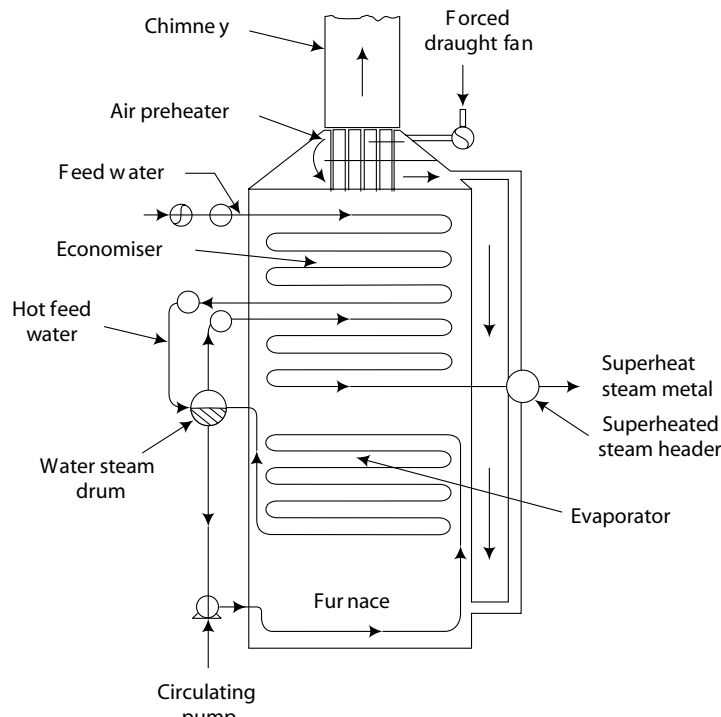

Fig. 1.6 High pressure Lamont boiler

a water gauge, a pressure gauge, safety valves and a blow-off valve. Normally, three safety valves are fitted in high-pressure boilers. The design, manufacture and erection of such high-pressure boilers are very difficult. It needs a large number of skilled personnel, good team work and large investment.

1.8 BENSON BOILER

This is very similar to the Lamont Boiler, but *there is no drum*. This boiler can *withstand very high pressure*, even higher than critical pressure of steam. Absence of the drum *reduces the weight and cost*. The arrangement of various components is given in Fig. 1.7.

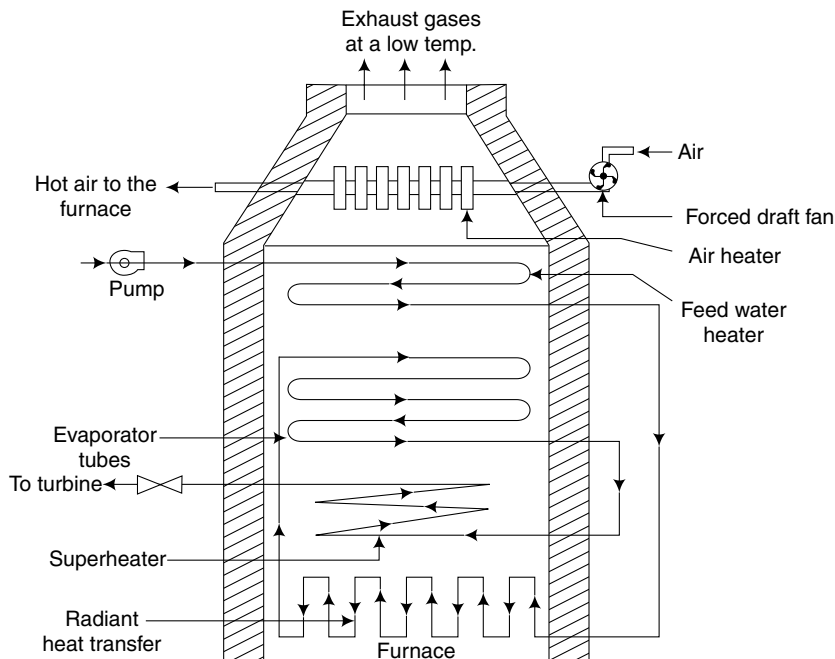

Fig. 1.7 Benson boiler

1.9 ADVANTAGES OF HIGH PRESSURE BOILERS

1. High pressure steam out of the boiler will have higher heat energy per kg. So, power output from the turbine and the generator will be high.
2. The thermal efficiency of a high pressure boiler is much higher than the low pressure or medium pressure boilers.
3. Evaporative capacity of the boiler is high due to forced circulation of water.
4. The investment cost for each MW output will be less, by using a high pressure boiler.

1.10 CHARACTERISTICS OF A GOOD BOILER

1. The boiler should be able to evaporate steam at the designed capacity, pressure and temperature.

2. Total cost of the boiler with all mountings and accessories should be low.
3. By having a higher thermal efficiency, the operational cost should be low.
4. The boiler should have provision for inspection of all the parts for cleaning and maintenance.
5. The boiler should have provision for automatic control of water level, pressure and temperature.
6. The parts should be able to withstand the fluctuations in pressure and temperature.
7. Transport and erection of the boiler at site should be easy and at the minimum cost.
8. The boiler should conform to all the safety regulations, as laid down in the Indian Boiler Act.

1.11 INDIAN BOILER ACT

1. Unless the boiler is registered with the Chief Inspector of Boilers, it should not be put into operation.
2. Fitness Certificate should be obtained every year, from the Chief Inspector of Boilers.
3. The certificate should be displayed in the boiler room.
4. The boiler operator should be a trained person.
5. Any failure or accident should be immediately reported to the Chief Inspector.
6. Any violation of the act is punishable.

1.12 DIFFERENCES BETWEEN FIRE-TUBE AND WATER-TUBE BOILERS

Table 1.1

	Fire-tube boiler	Water-tube boiler
1.	Hot gases pass through the tubes with water surrounding them.	Water passes through the tubes with hot gases surrounding them.
2.	Used for low-pressure steam as the diameter of the shell is large. The pressure is restricted to about 10 bar.	Drum diameter is less and it can be used for medium and high pressure. Pressure of steam can even go up to about 100 bar.
3.	Used for industrial applications only due to low pressure.	<i>Used for power plants</i> where we need high pressure.
4.	More steam space and so pressure fluctuation is less.	Less steam space; pressure fluctuation is more when the steam is taken out.
5.	Transport is difficult due to large shell diameter.	Comparatively easier due to smaller drum.
6.	Less number of parts.	More number of parts.
7.	Fire tube will not be choked easily. Maintenance cost is less.	These boilers can be choked due to salt deposits. Maintenance cost is more.
8.	Water circulation is poor.	Water circulation is better.
9.	Thermal efficiency is low.	Thermal efficiency is high.
10.	Heating surface is less.	Heating surface is more due to large number of water tubes.
11.	Less skill is enough for the operation of the boiler.	More skill and controls are needed for the operation of the boiler.

1.13 COGENERATION

It should be remembered that the thermal efficiency of any heat engine is rather low in the range of 15 to 35 percent. When a heat engine is not able to convert all the input heat energy into useful mechanical power, it would be obviously rejecting energy as waste heat. So, a system will become more efficient if the waste heat is utilised for some useful purpose. Any scheme which combines electrical power generation with utilisation of heat for industrial processes and/or space heating is referred to as Combined Heat and Power (CHP) or Cogeneration. In such a scheme, energy wastage is reduced to the minimum thereby increasing the overall thermal efficiency.

Refer to Fig. 1.8. This cogeneration power plant employs both the steam turbine and a gas turbine for generating electric power. Because of recovery of heat from the flue gases of the boiler and the exhaust gases from the gas turbine, we obtain high overall thermal efficiency.

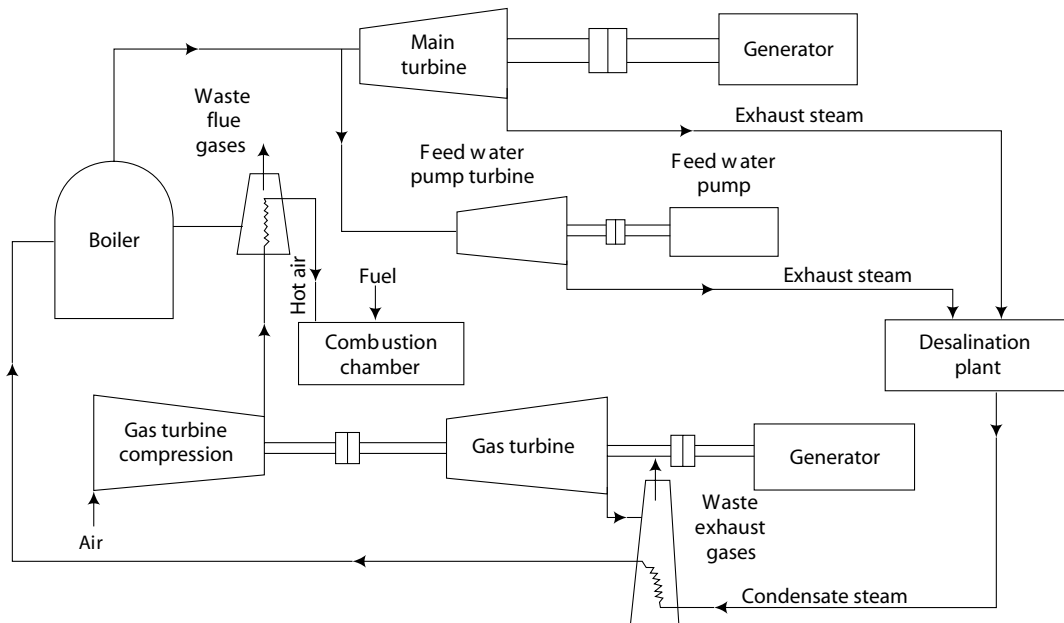

Fig. 1.8 Cogeneration

Steam is generated at high pressure and temperature in the boiler. Steam from the boiler is fed to the main steam turbine for generating electric power and also to a small turbine which drives the feed water pump. Both the turbines are back pressure, non-condensing type and the steam in the last stages of the turbines is fed into the desalination plant to purify sea water for getting soft water. Thus, it is noted that the desalination plant is operated by using the heat from the exhaust or waste steam from the turbines.

In addition, the heat energy in the flue gases from the boiler instead of being wasted is used to preheat the compressed air used in the gas-turbine combustion chamber. The hot exhaust from the gas turbine is made to heat the condensate feed water from the desalination plant. The above two waste heat recoveries help in increasing the thermal efficiency of the power plant by reducing

the fuel burnt in the gas turbine combustion chamber and also in the boiler for the same output power.

To cite an example, in the case of a gas turbine power plant, heat from the exhaust gases could be made use of in the waste heat recovery boiler. Even after this, the gases could then be passed through an economiser to preheat the feed water for the boiler. Nowadays, this principle is made use of in many ways in thermal plants.

1.14 INTRODUCTION TO STEAM TURBINES

A steam turbine is a prime mover in which rotary motion is obtained by the gradual change of momentum of the steam. Steam turbines are primarily used to run alternators or generators in thermal power plants. It is also used to rotate the propeller of ships through reduction gearing. The design and manufacture of turbine blades are quite complicated due to which there are only a limited number of manufactures of steam turbines.

1.15. MAIN PARTS OF A STEAM TURBINE

Nozzles In steam turbines, normally, convergent–divergent type of nozzles are used. When steam flows through the nozzle, there is a pressure drop which is converted into velocity or kinetic energy. The nozzle also guides the steam in the proper direction to strike the blades. The nozzles are kept very close to the blades to minimise the losses.

Rotor The rotor or runner consists of a circular disc fixed to a horizontal shaft. The rotor is mounted on suitable bearings.

Blades On the periphery of the rotor, a large number of blades are fixed. The steam jet from the nozzle impinges on the surface of the blades due to which the rotor rotates. The surface of the blades is made smooth to reduce frictional losses.

Casing It is a steam tight steel casing which encloses the rotor, blades, etc. In a multistage turbine, the casing also accommodates the fixed blades. The casing helps the flow of steam and also protects the inner parts from any accident.

1.16 TYPES OF TURBINES

Steam turbines are classified as impulse turbines and reaction turbines. Differences between the terms impulse and reaction are explained below:

Impulse is the force imparted on an object when a jet of fluid strikes the object with great velocity as in Fig. 1.9(a). Reaction is the force imparted on an object when a fluid leaves the object with a higher relative velocity. Different examples of reaction are swimming, recoil of a gun, jet plane, ground wheel in fire works, lawn sprinkler, etc. In Fig. 1.9(b), the jet plane moves forward due to the reaction of the high velocity jet of hot gases from the nozzle. In Fig. 1.9(c), the lawn sprinkler rotates due to the reaction of the water jets.

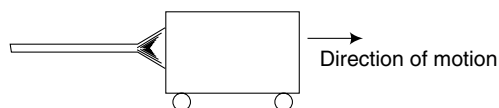

Fig. 1.9(a) *Impulsive force of a fluid jet*

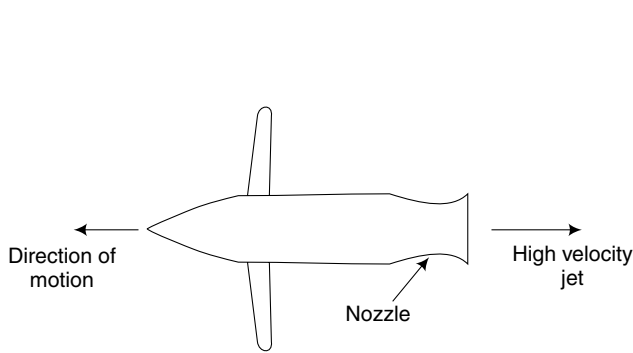

Fig. 1.9(b) *Jet Plane*

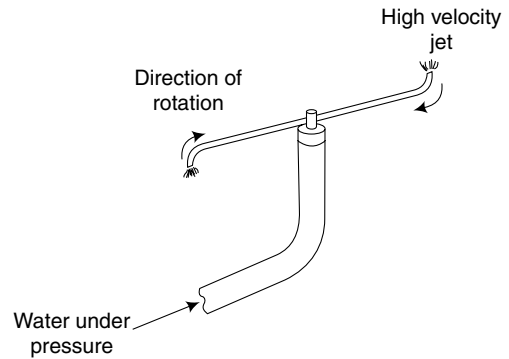

Fig. 1.9(c) *Lawn sprinkler*

1.17 WORKING OF A SINGLE-STAGE IMPULSE TURBINE (DE-LAVAL TURBINE)

First, the pressure energy is converted into kinetic energy by the expansion of steam through a set of nozzles. Normally, in steam turbines, we make use of convergent–divergent nozzles. The kinetic energy is converted into mechanical energy with the help of moving blades fixed on a rotor. The rotor is connected to the output shaft. All the above-mentioned parts are enclosed in a casing as shown in Fig. 1.10(a). The pressure–velocity diagram, given in Fig. 1.10(b), is for a single-stage impulse turbine.

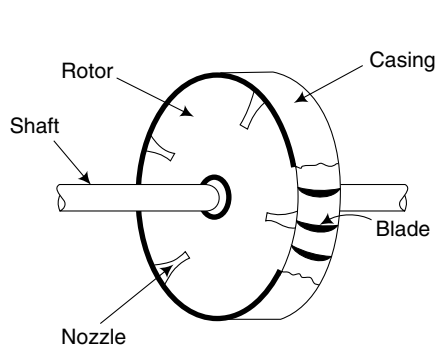

Fig. 1.10(a) *Single-stage impulse turbine*

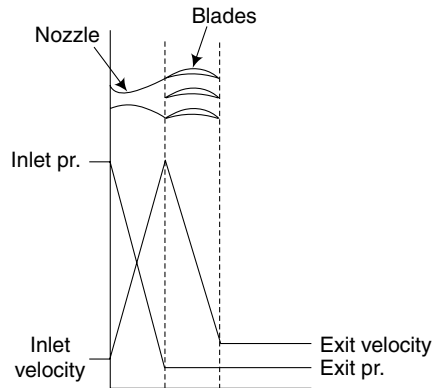

Fig. 1.10(b) *Pressure velocity diagram for a single-stage impulse turbine*

A simple or single-stage impulse turbine is only suitable for low-pressure steam. In case the steam pressure is high, when it expands in one set of nozzles, the outlet velocity of steam from the end of the nozzles will be too high. Due to the high velocity of the steam, the rotor will rotate at a very high speed. Such a high speed is not suitable for practical purposes. So, in practice, we make use of the multistage impulse turbines or compound impulse turbines.

1.18 COMPOUNDING OF IMPULSE STEAM TURBINES

In multistage impulse turbines, there are three types of compounding, namely, pressure compounding, velocity compounding and pressure velocity compounding. In this section, the three types are discussed.

1.18.1 Pressure Compounding

The pressure drop or expansion of steam is done in more than one set of nozzles and each set of nozzles is followed by a set of moving blades. The turbine is known as pressure compounded impulse turbine. A two-stage pressure compounding is shown in Fig. 1.11(a).

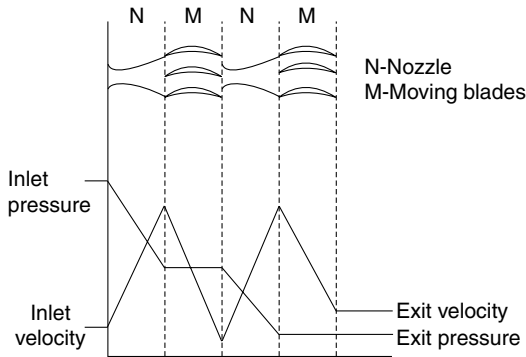

Fig. 1.11(a) 2-Stage pressure compounding

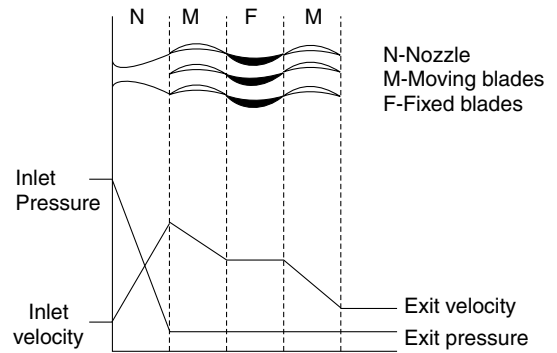

Fig. 1.11(b) 2-Stage velocity compounding

1.18.2 Velocity Compounding

Here the entire expansion of steam occurs in one set of nozzles resulting in a very high velocity at the outlet. The steam is then passed through several sets of moving blades, followed by fixed blades. Moving blades are fitted on the rotor while the fixed blades are fixed on the casing. The function of the fixed blades is to change the direction of steam and guide the steam in the proper angle to the next set of moving blades. A two-stage velocity compounding is shown in Fig. 1.11(b).

1.18.3 Pressure Velocity Compounding

In power plants, pressure velocity compounding is more common. In this arrangement, for each pressure stage, there is a velocity staging. A two-stage pressure velocity compounding is shown in Fig. 1.11(c). In practice, there will be more than 20 stages in a power station.

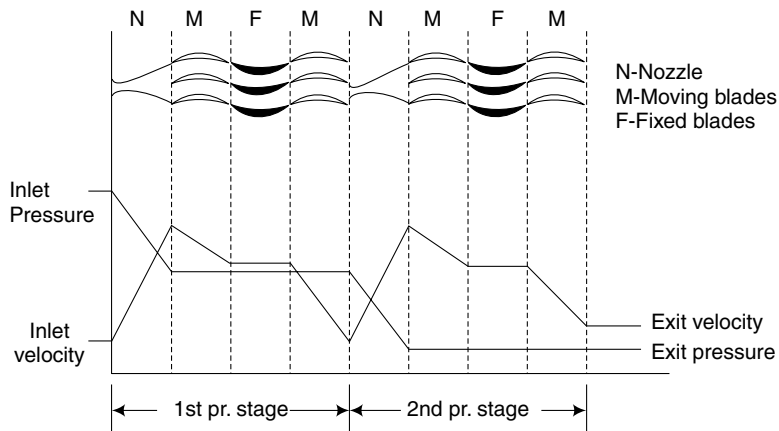

Fig. 1.11(c) 2-Stage pressure velocity compounding

1.19 WORKING OF PARSON'S REACTION TURBINE

In this turbine, the power is obtained mainly by an impulsive force of the incoming steam and small reactive force of the outgoing steam. As shown in Fig. 1.12(a), this turbine consists of a rotor of a varying diameter. Moving blades are fixed on the rotor. The diameter of the casing also varies. Fixed blades are attached to the casing. Steam is admitted to the first set of moving blades through nozzles. The blades receive the impulsive force of the incoming steam. Then it goes to fixed blades which act as nozzles! Thus, steam flows alternatively through moving and fixed blades.

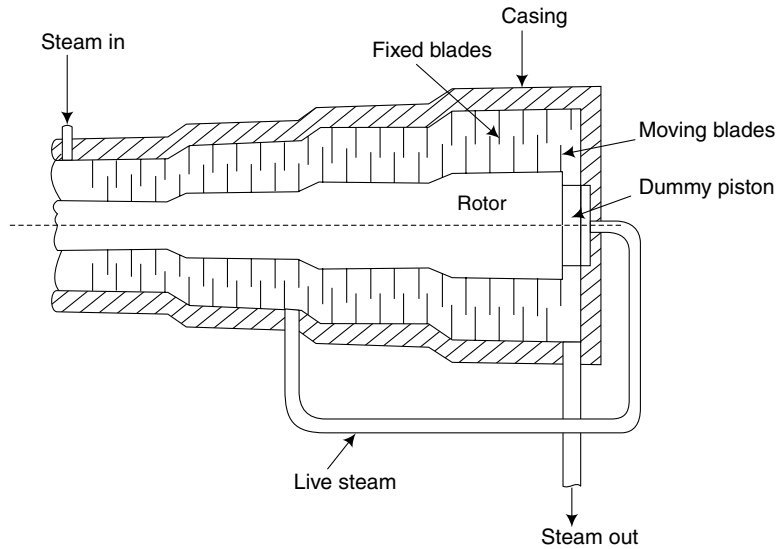

Fig. 1.12(a) Parson's reaction turbine

The shape of the moving blades is so designed to also have the reactive force when the jet of steam is leaving the blades. For this, area of the outlet between the two moving blades will be less than the area at the inlet. In addition, there will be also some pressure drop even in the moving blades. Thus, we have a continuous pressure drop in the fixed as well as in the moving blades as in Fig. 1.12(b), in reaction turbines.

The diameters of the rotor and casing gradually increase to accommodate the increasing volume of steam at reduced pressure. The size of the blades also increases

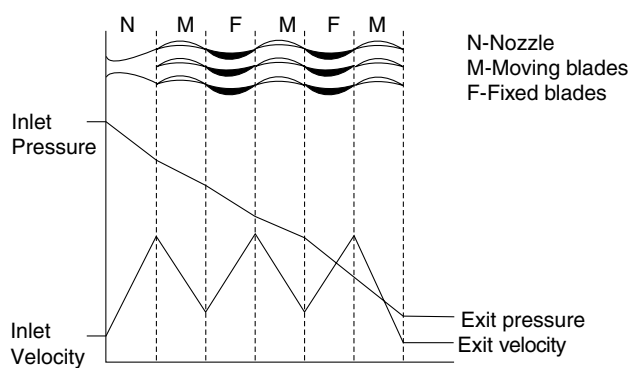

Fig. 1.12(b) Pressure drop in a reaction turbine

The diameters of the rotor and casing gradually increase to accommodate the increasing volume of steam at reduced pressure. The size of the blades also increases in the direction of flow. A dummy piston is used to balance the axial thrust of the rotor by allowing live steam to act on one side of the dummy piston, opposite to the direction of steam flow. In case the axial thrust is not balanced properly, there will be undue and uneven wear in the turbine shaft.

1.20 DIFFERENCES BETWEEN IMPULSE AND REACTION TURBINES

Table 1.2

	Impulse turbine	Reaction turbine
1.	Power is obtained only due to the impulsive force of the incoming steam.	Power is due to both the impulsive force of the incoming steam and due to the reactive force of the outgoing steam.
2.	Pressure drop is only in the nozzle or in the fixed blades which act as nozzles. There is no pressure drop in moving blades.	Pressure drop is in the fixed and also in the moving blades.
3.	The relative velocity of steam at inlet and outlet of the moving blades are equal.	The relative velocity of steam at outlet is higher to get the reactive force.
4.	Blades are symmetrical.	Blades are not symmetrical.
5.	Inlet area of moving blades is equal to the outlet area as in Fig. 1.13 (a).	Outlet area of the moving blades is smaller than the inlet area as shown in Fig. 1.13 (b),

Short-Answer Questions

1. Answer the following questions:
 - (a) State some of the applications of steam boilers.
 - (b) Classify different steam boilers.
 - (c) What are the requirements of a good boiler?
 - (d) What are water gauges?
 - (e) What are the specific advantages of water-tube boilers?
 - (f) Give three examples each of boiler mountings and boiler accessories.
 - (g) What are the aims of pre-heating of air in a boiler?
 - (h) How does a fusible plug function as a safety device?
 - (i) What is meant by superheated steam?
 - (j) What are the commercial fuels used in boilers?
 - (k) What is meant by cogeneration?
 - (l) What are the essential components of a cogeneration plant?

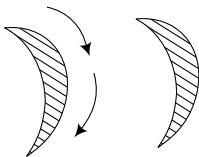

Fig. 1.13(a) Moving blades of impulse turbine

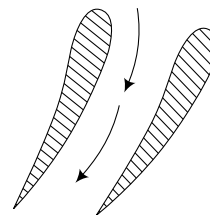

Fig. 1.13(b) Moving blades of reaction turbine

- (m) What are the main parts of a steam turbine?
- (n) What is the function of a steam nozzle?
- (o) Define the terms impulse and reaction with examples.
- (p) Draw pressure-velocity diagram for a single stage impulse turbine.
- (q) What are the three types of compounding in impulse steam turbines?
- (r) Define the terms:
 - (i) pressure compounding
 - (ii) velocity compounding
- (s) State any two important differences between the impulse and reaction steam turbines.

2. Fill up the blanks with suitable word/words:

- (a) Cochran boiler is a _____ boiler and Babcock and Wilcox boiler is a _____ boiler.
- (b) The two types of draught employed in boilers are _____ and _____.
- (c) _____ and _____ are modern high pressure boilers.
- (d) The two types of superheaters used in high pressure boilers are _____ and _____.
- (e) Rotary motion of a turbine is obtained by the gradual change of _____ of steam.
- (f) When steam flows through nozzle, _____ is converted into _____.
- (g) Pressure energy is converted into kinetic energy by the _____ of steam through a nozzle.
- (h) _____ is converted into _____ with the help of moving blades.

3. Choose the correct answer from the following:

- (a) The water tubes in a Babcock and Wilcox boiler are
 - (i) vertical
 - (ii) horizontal
 - (iii) inclined
 - (iv) none of the above
- (b) The condition of steam in the boiler drum is usually
 - (i) superheated
 - (ii) super saturated
 - (iii) wet
 - (iv) none
- (c) In an impulse turbine, when steam flows through the moving blades,
 - (i) velocity decreases
 - (ii) velocity increases
 - (iii) pressure decreases
 - (iv) pressure increases
- (d) In reaction turbine, when steam flows through the fixed blades,
 - (i) pressure and velocity both increase
 - (ii) pressure and velocity both decrease
 - (iii) pressure decreases, while velocity increases
 - (iv) pressure decreases, while velocity decreases
- (e) In pressure compounded impulse turbine
 - (i) pressure drop for each stage is equal
 - (ii) pressure drop takes place in nozzle

- (iii) both (i) and (ii)
 - (iv) none of the above
 - (f) In velocity compounded impulse turbine, when steam flows through the second row of moving blades,
 - (i) velocity increases
 - (ii) velocity decreases
 - (iii) velocity remains constant
 - (g) In steam turbines, blades are
 - (i) straight
 - (ii) curved
 - (iii) circular
 - (iv) none of the above
4. State whether the following statements are true or false:
- (a) Heating of steam above saturation temperature is called superheating.
 - (b) Cochran boiler is a horizontal water-tube boiler.
 - (c) Fusible plug is employed to make a spark.
 - (d) All fire-tube boilers are high pressure boilers.
 - (e) Formation of scale on a boiler tube decreases its life.
 - (f) Pressure drop is converted into mechanical energy in nozzle.
 - (g) Pressure falls gradually in reaction turbines in fixed and moving blades.
 - (h) Turbine blades are circular.
 - (i) Steam nozzle converts heat energy of steam into pressure energy.
 - (j) When the cross section of a nozzle first decreases from its entrance to throat and then increases from its throat to exit, the nozzle is known as convergent nozzle.
 - (k) Steam enters the steam nozzle at high pressure and high velocity.
 - (l) Steam leaves the nozzle at high pressure and high velocity.
 - (m) In reaction turbine, the driving force is only reaction force.

Long-Answer Questions

1. Describe the working of Parson's reaction turbine.
2. What is meant by cogeneration? What are the essential components of a cogeneration plant?
3. What is meant by pressure compounding and velocity compounding?
4. Explain the formation of steam with a graph.
5. What is specified in the Indian Boilers Act.
6. What are the differences between the impulse and reaction steam turbines.