

## 4.2 INTEL 8259A Programmable Interrupt Controller

The 8259A is a programmable interrupt controller designed to work with Intel microprocessor 8080 A, 8085, 8086, 8088. The 8259 A interrupt controller can

- 1) Handle eight interrupt inputs. This is equivalent to providing eight interrupt pins on the processor in place of one INTR/INT pin.
- 2) Vector an interrupt request anywhere in the memory map. However, all the eight interrupt are spaced at the interval of either four or eight location. This eliminates the majordrawback, 8085 interrupt, in which all interrupts are vectored to memory location on page 00H.
- 3) Resolve eight levels of interrupt priorities in a variety of modes.
- 4) Mask each interrupt request individually.
- 5) Read the status of pending interrupts, in service interrupts, and masked interrupts.
- 6) Be set up to accept either the level triggered or edge triggered interrupt request.
- 7) Mine 8259 as can be cascade in a master slave configuration to handle 64 interrupt inputs.

The 8259 A is contained in a 28-element in line package that requires only a compatible with 8259. The main difference between the two is that the 8259 A can be used with Intel 8086/8088 processor.

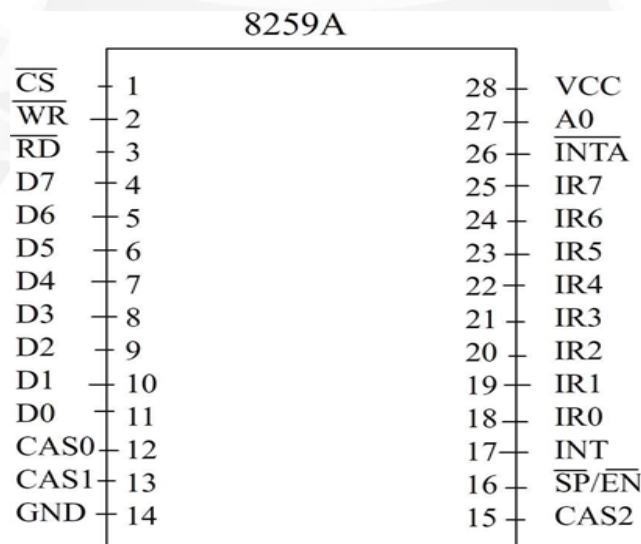

**Figure 4.2.1 Pin diagram of 8259A**

[Source: "Microprocessor Architecture Programming and Application" by R.S. Gaonkar, page- ]

It also induces additional features such as level triggered mode, buffered mode and automatic end of interrupt mode. The pin diagram and interval block diagram is shown in 4.2.1.

Symbol	Pin No.	Type	Name and Function
VCC	2 8	I	SUPPLY: + 5V Supply.
GND	1 4	I	GROUND
CS	1	I	CHIP SELECT: A low on this pin enables RD and WR communication between the CPU and the 8259A. INTA functions are independent of CS
WR	2	I	WRITE: A low on this pin when CS is low enables The 8259A to accept command words from the CPU.
RD	3	I	READ: A low on this pin when CS is low enables the 8259A to release status onto the data bus for the CPU.
D7–D0	4 –11	I/O	BIDIRECTIONAL DATA BUS: Control, status and interrupt-vector information is transferred via this bus.
CAS0–CAS2	12, 13, 15	I/O	CASCADE LINES: The CAS lines form a private 8259A bus to control a multiple 8259A structure. These pins are outputs for a master 8259A and Inputs slave 8259A.

The 8259 A has eight interrupt request inputs, TR2 IR0. The 8259 A uses its INT output to interrupt the 8085A via INTR pin. The 8259A receives interrupt acknowledge pulses from the at its input. Vector address used by the 8085 A to transfer control to the service subroutine of the interrupting device, is provided by the 8259 A on the data bus. The 8259A is a programmable device that must be initialized by command words sent by the. After initialization, the 8259 A mode of operation can be changed by operation command words from the. The descriptions of various blocks are,

Data bus buffer - This 3- state, bidirectional 8-bit buffer is used to interface the 8259A to the system data bus. Control words and status information are transferred through the data bus buffer.

8259 internal block diagram

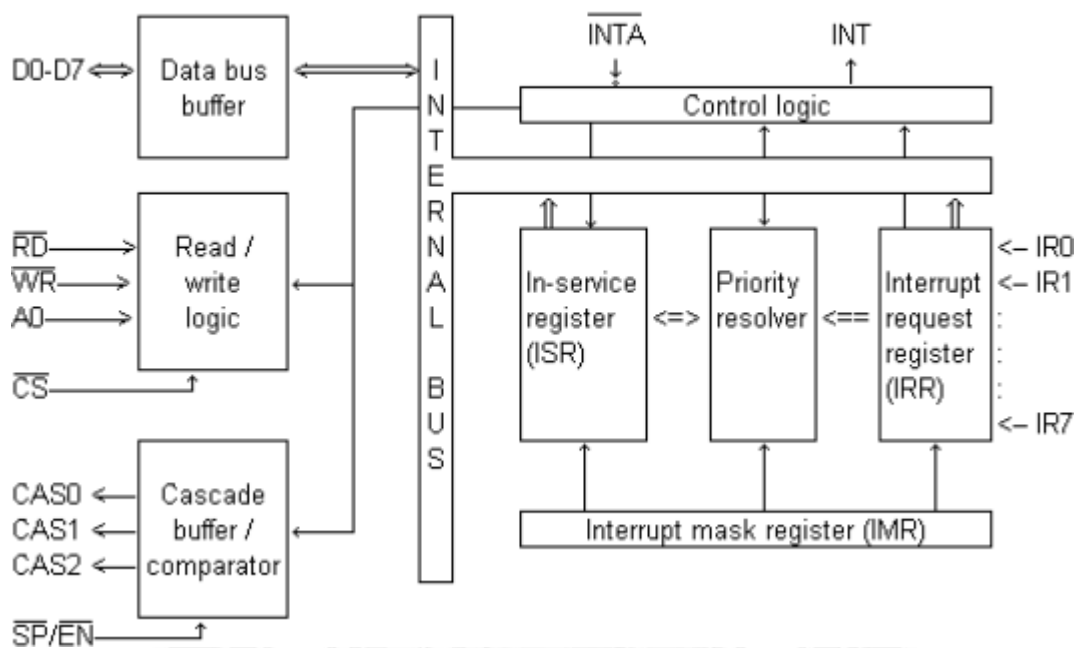
**Figure 4.2.2 Architecture of 8259A**

[Source: "Microprocessor Architecture Programming and Application" by R.S. Gaonkar, page- ]

**Read/Write & control logic** - The function of this block is to accept OUTPUT commands from the CPU. It contains the initialization command word (ICW) register and operation command word (OCW) register which store the various control formats for device operation. This function block also allows the status of 8159A to be transferred to the data bus.

**Interrupt request register (IRR)** - IRR stores all the interrupt inputs that are requesting service. Basically, it keeps track of which interrupt inputs are asking for service. If an interrupt input is unmasked, and has an interrupt signal on it, then the corresponding bit in the IRR will be set.

**Interrupt mask register (IMR)** -The IMR is used to disable (Mask) or enable (Unmask) individual interrupt inputs. Each bit in this register corresponds to the interrupt input with the same number. The IMR operation on the IRR. Masking of higher priority input will not affect the interrupt request lines of lower priority. To unmask any interrupt the corresponding bit is set „0“.

**In service register (ISR)** - The in-service registers keeps tracks of which interrupt inputs are currently being serviced. For each input that is currently being serviced the corresponding bit will be set in the in-service register. Each of these 3-reg can be read as status reg.

**Priority Resolver** -This logic block determines the priorities of the set in the IRR. The highest priority is selected and strobed into the corresponding bit of the ISR during pulse.

**Cascade buffer/comparator** - This function blocks stores and compare the IDS of all 8259A's in the reg. The associated 3-I/O pins (CAS0-CAS2) are outputs when 8259A is used a master. Master and are inputs when 8259A is used as a slave. As a master, the 8259A sends the ID of the interrupting slave device onto the cas2-cas0. The slave thus selected will send its pre-programmed subroutine address on to the data bus during the next one or two successive pulses.

