

# Thevenin's Theorem

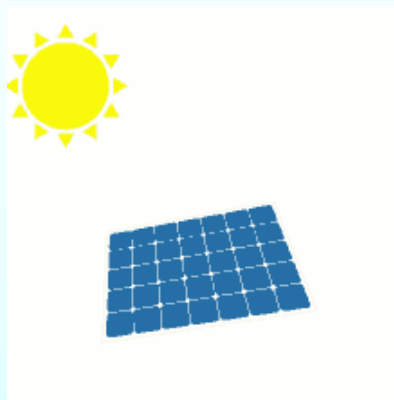

**Mr.Ebbie Selva Kumar C**

Assistant Professor/ EEE

*Rohini College of Engineering and Technology*



## Thevenin's Theorem

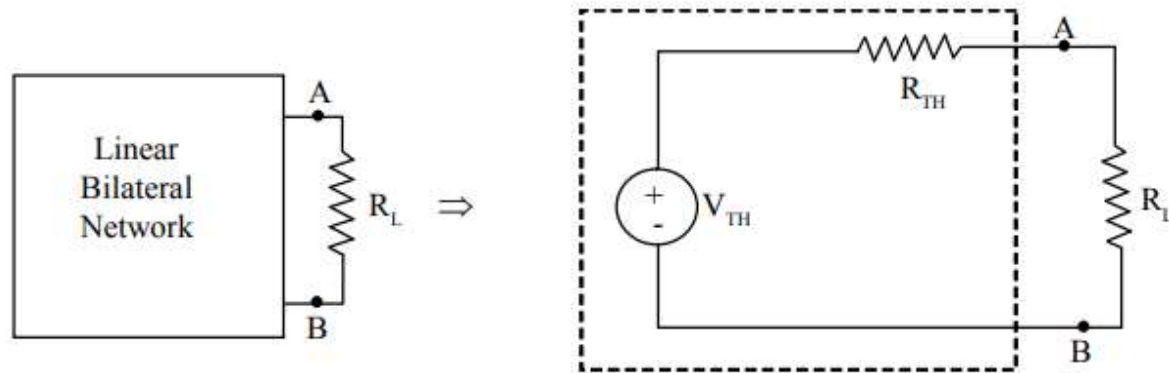

Thevenin's theorem is also known as "Helmholtz Theorem".

### *Statement :*

"Any two terminal linear bilateral network can be represented as a series combination of  $V_{TH}$  and  $R_{TH}$ .  $V_{TH}$  is the open circuit voltage measured between A and B after disconnecting the load resistance ( $R_L$ ).  $R_{TH}$  is the thevenin's resistance measured between A and B by reducing the independent sources in the network to zero".

Independent voltage source is reduced to zero by short circuit. Independent current source is reduced to zero by open circuit it.



### ***Steps for Solving a Network using Thevenin's theorem :***

1. Disconnect the load resistance ( $R_L$ ).
2. Calculate the thevenin's voltage  $V_{AB}$  using loop analysis or node analysis or series parallel reduction.
3. Calculate thevenin's resistance by series parallel reduction.
4. Draw the thevenin's network and calculate the load current by connecting load resistance between A and B.

$$\therefore I_L = \frac{V_{TH}}{R_{TH} + R_L}$$



**Proof :**

Consider the circuit shown below.

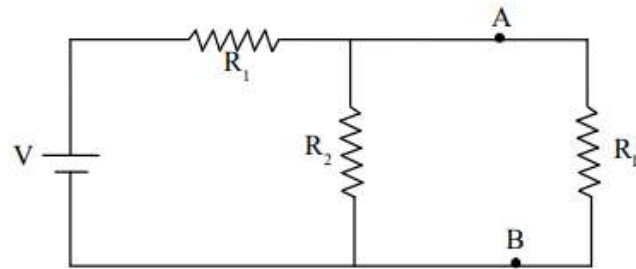

1. Disconnect  $R_L$ .

2. Calculate  $V_{AB}$ .

The voltage  $V_{AB}$  is same as voltage across  $R_2$ .

$$V_{TH} = IR_2$$

$$= \frac{V}{R_1 + R_2} R_2$$

-----(1)

3. Calculate  $R_{TH}$ .

$$R_{TH} = \frac{R_1 R_2}{R_1 + R_2}$$

-----(2)

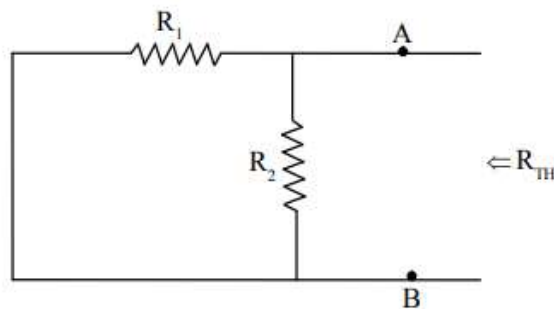

4. Calculate the load current  $I_L$

$$I_L = \frac{V_{TH}}{R_{TH} + R_L} \quad \text{-----(3)}$$

Substitute equation (1) & (2) in equation (3), we get

$$I_L = \frac{\frac{VR_2}{R_1 + R_2}}{\frac{R_1 R_2}{R_1 + R_2} + R_L} = \frac{VR_2 / R_1 + R_2}{R_1 R_2 + R_L (R_1 + R_2)}$$

$$\therefore I_L = \frac{VR_2}{R_1 R_2 + R_L (R_1 + R_2)} \quad \text{-----(4)}$$

**Verification By Loop or Mesh Analysis**

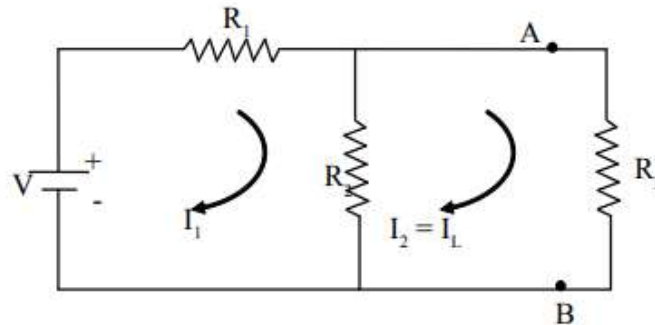

By mesh analysis,

$$\begin{bmatrix} R_1 + R_2 & -R_2 \\ -R_2 & R_2 + R_L \end{bmatrix} \begin{bmatrix} I_1 \\ I_2 \end{bmatrix} = \begin{bmatrix} V \\ 0 \end{bmatrix}$$



$$I_2 = \frac{\begin{vmatrix} R_1 + R_2 & V \\ -R_2 & 0 \end{vmatrix}}{\begin{vmatrix} R_1 + R_2 & -R_2 \\ -R_2 & R_2 + R_L \end{vmatrix}}$$

$$I_2 = \frac{VR_2}{(R_1 + R_2)(R_2 + R_L) - R_2^2}$$

$$I_2 = \frac{VR_2}{R_1R_2 + R_1R_L + R_2^2 + R_2R_L - R_2^2}$$

$$I_2 = \frac{VR_2}{R_1R_2 + R_L(R_1 + R_2)} \text{-----(5)}$$



By thevenins theorem, the circuit can be reduced at AB to the circuit as shown below.

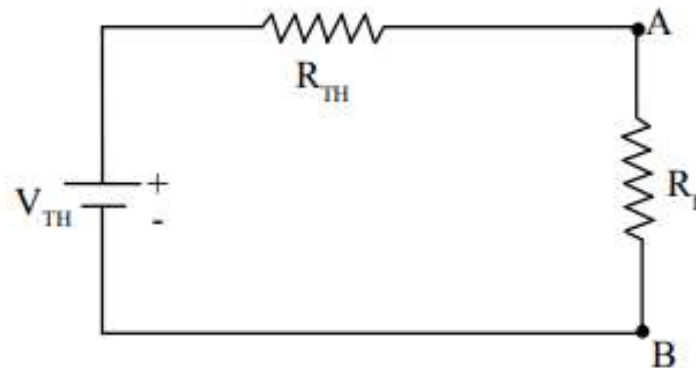

∴ Equation (5) is same as equation in (4)

This proves thevenin's theorem.

Calculate the load current  $I_L$

$$I_L = \frac{V_{TH}}{R_{TH} + R_L}$$



**Thank You**

