

1.2 KIRCHHOFFS FIRST LAW – THE CURRENT LAW, (KCL)

Kirchhoffs Current Law or KCL, states that the “total current or charge entering a junction or node is exactly equal to the charge leaving the node as it has no other place to go except to leave, as no charge is lost within the node“. In other words the algebraic sum of ALL the currents entering and leaving a node must be equal to zero, $I_{(exiting)} + I_{(entering)} = 0$. This idea by Kirchoff is commonly known as the Conservation of Charge.

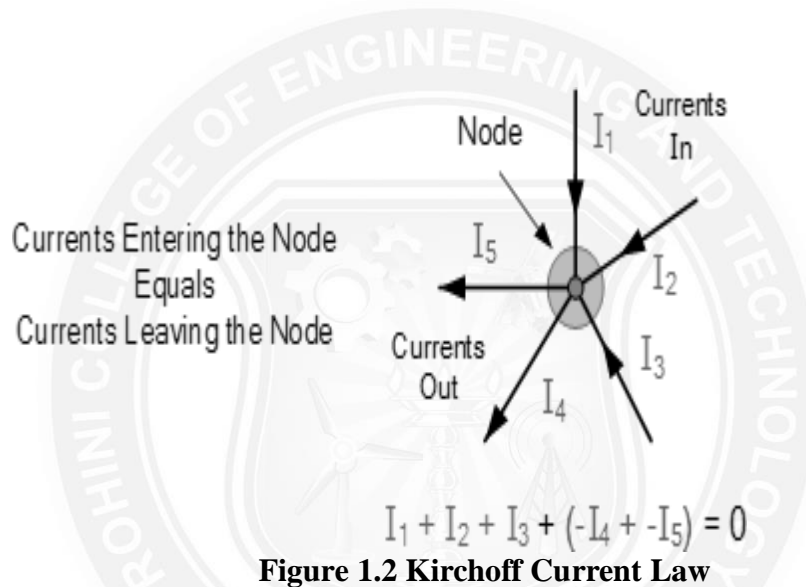

Figure 1.2 Kirchoff Current Law

Here, the three currents entering the node, I_1, I_2, I_3 are all positive in value and the two currents leaving the node, I_4 and I_5 are negative in value. Then this means we can also rewrite the equation as;

$$I_1 + I_2 + I_3 - I_4 - I_5 = 0$$

The term Node in an electrical circuit generally refers to a connection or junction of two or more current carrying paths or elements such as cables and components. Also for current to flow either in or out of a node a closed circuit path must exist. We can use Kirchoff's current law when analysing parallel circuits.

Kirchhoffs Second Law – The Voltage Law, (KVL)

Kirchhoffs Voltage Law or KVL, states that “in any closed loop network, the total voltage around the loop is equal to the sum of all the voltage drops within the same loop” which is also equal to zero. In other words the algebraic sum of all voltages within the loop must be equal to zero. This idea by Kirchoff is known as the

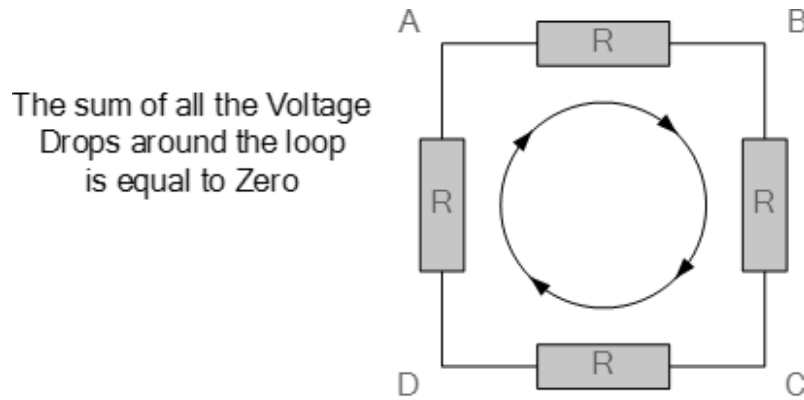

$$V_{AB} + V_{BC} + V_{CD} + V_{DA} = 0$$

Starting at any point in the loop continue in the same direction noting the direction of all the voltage drops, either positive or negative, and returning back to the same starting point. It is important to maintain the same direction either clockwise or anti-clockwise or the final voltage sum will not be equal to zero. We can use Kirchhoff's voltage law when analysing series circuits.

When analysing either DC circuits or AC circuits using Kirchoffs Circuit Laws a number of definitions and terminologies are used to describe the parts of the circuit being analysed such as: node, paths, branches, loops and meshes. These terms are used frequently in circuit analysis so it is important to understand them.