

Basics of Speed Governing Mechanisms and Modelling

The speed governor is the main primary tool for the LFC, whether the machine is used alone to feed a smaller system or whether it is a part of the most elaborate arrangement. A schematic arrangement of the main features of a speed-governing system of the kind used on steam turbines to control the output of the generator to maintain constant frequency is as shown in Fig.1

Its main parts or components are as follows:

Fly Ball Speed Governor:

This is the heart of the system which senses the change in speed (frequency). As the speed increases the fly balls move outwards and the point B on linkage mechanism moves downwards. The reverse happens when the speed decreases.

(i) Hydraulic Amplifier:

It comprises a pilot valve and main piston arrangement. Low power level pilot valve movement is converted into high power level piston valve movement. This is necessary in order to open or close the steam valve against high pressure steam.

(ii) Linkage Mechanism:

ABC is a rigid link pivoted at B and CDE is another rigid link pivoted at D. This linkage mechanism provides a movement to the control valve in proportion to change in speed. It also provides a feedback from the steam valve movement.

Basics of Speed Governing Mechanisms and Modelling

(iii) Speed Changer: It provides a steady state power output setting for the turbine. Its downward movement opens the upper pilot valve so that more steam is admitted to the turbine under steady conditions (hence more steady power output). The reverse happens for upward movement of speed changer.

A brief explanation of the diagram is as follows:

Steam enters into the turbine through a pipe that is partially obstructed by a steam admission valve. In steady state the opening valve is determined by the position of a device called the speed changer (upper left corner in Fig.1), fixes the position of the steam valve through two rigid rods ABC and CDE. The reference value or set point of the turbine power in steady state is called the reference power. When the load on the bus suddenly changes, the shaft speed is modified, and a device called speed regulator acts through the rigid rods to move the steam valve. A similar effect could be produced by temporarily modifying the reference power (which justifies the name speed changer). In practice, both control schemes are

used simultaneously. Amplifying stages (generally hydraulic) are introduced to magnify the output of the controller and produced the forces necessary to actually move the steam valve.

Modelling of Speed Governor

In this section, we develop the mathematical model based on small deviations around a nominal steady state. Let us assume that the steam is operating under steady state and is delivering power P^0_G from the generator at nominal speed or frequency f_0 . Under this condition, the prime mover valve has a constant setting χ^0_E , the pilot valve is closed, and the linkage mechanism is stationary. Now, we will increase the turbine power by ΔP_C with the help of the speed changer. For this, the movement of linkage point A moves downward by a small distance ΔX_A and is given by

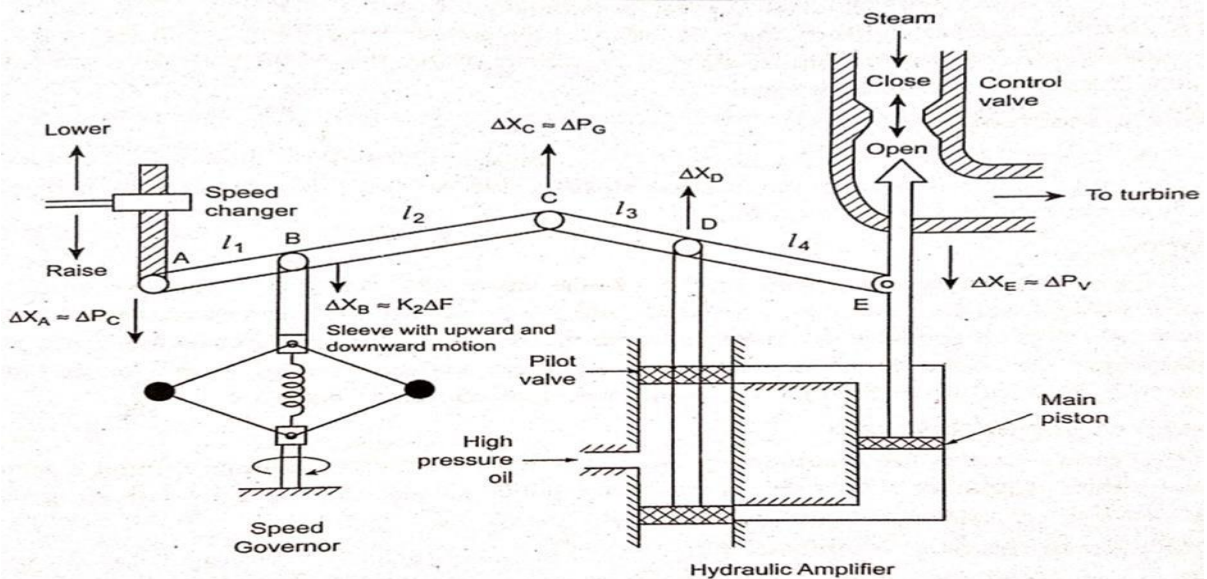

Fig.1 Schematic diagram of speed governing mechanism

$$\Delta X_A = K_c \Delta P_C \dots\dots\dots (1)$$

The link point 'C' will move upward because of linkage (A-B-C) action. Let it be further, the link point 'D' moves the piston in pilot servo (V), resulting in higher pressure oil flow in the upper part of the main piston. The piston moves downward by an amount ΔX_D and the steam valve opening increases. It increases the torque developed by the turbine. This increased torque

increases the speed of generator, i.e., frequency (Δf). This change of speed results in the outward movement of fly ball of the speed regulator. Thus the link 'B' moves slightly downward a small distance ΔX_B . Due to the movement of link point B, the link point 'C' also moves downward by an amount ΔX_C which is also proportional to Δf . Thus the net movement of link point C is

$$\Delta X_C = \Delta X_{C'} + \Delta X_{C''} \dots\dots\dots (2)$$

$$(-) \Delta X_{C'} (l_{AB}) = \Delta X_A (l_{BC})$$

$$(-) \Delta X_{C'} = \Delta X_A \frac{(l_{BC})}{(l_{AB})} \dots\dots\dots (3)$$

We know from eq-(1) $\Delta X_A = K_c \Delta P_C$ substitute in eq-(3) and consider

$$K_1 = \frac{(l_{BC})}{(l_{AB})}$$

$$\Delta X_{C'} = (-) K_c \Delta P_C K_1$$

$$\Delta X_{C'} = (-) K_1 K_c \Delta P_C \dots\dots\dots (4)$$

and $\Delta X_{C''} = K_2 \Delta f$

Thus the net movement of C is therefore

$$\Delta X_C = (-) K_1 K_c \Delta P_C + K_2 \Delta f \dots\dots\dots (5)$$

The movement of D, ΔX_D is the amount by which the pilot valve opens. It is contributed by ΔX_C and ΔX_E and can be written as

$$\Delta X_D = \Delta X_{D'} + \Delta X_{D''} \dots\dots\dots (6)$$

$$\Delta X_{D'} (l_{CD} + l_{DE}) = \Delta X_C (l_{DE})$$

$$\Delta X_{D'} = \frac{(l_{CD} + l_{DE})}{(l_{DE})} \Delta X_C \dots\dots\dots (7)$$

$$\Delta X_{D'} = K_3 \Delta X_C \dots\dots\dots (7)$$

$$\Delta X_{D''} (l_{CD} + l_{DE}) = \Delta X_E (l_{CD})$$

$$\Delta X_{D''} = \frac{(l_{CD} + l_{DE})}{(l_{CD})} \Delta X_E$$

$$\Delta X_{D''} = K_4 \Delta X_E \dots\dots\dots (8)$$

Thus, it can be written as

$$\Delta X_D = K_3 \Delta X_C + K_4 \Delta X_E \dots\dots\dots (9)$$

Now, if an assumption is made that the flow of oil into the servo-motor is proportional to position ΔX_D of the pilot valve V, then the movement ΔX_E of the piston can be expressed as

$$\Delta X_E = \Delta X_V = K_5 \int_0^t (-\Delta X_D) dt \dots\dots\dots (10)$$

Taking Laplace transform of equations (5), (9) and (10) ·

$$\Delta X_C(s) = -K_1 K_c \Delta P_C(s) + K_2 \Delta f(s) \quad \dots\dots\dots (11)$$

$$\Delta X_D(s) = K_3 \Delta X_C(s) + K_4 \Delta X_E(s) \quad \dots\dots\dots(12)$$

$$\Delta X_E(s) = K_5 \frac{1}{s} \Delta X_D(s) \quad \dots\dots\dots (13)$$

Eliminating $\Delta X_C(s)$ and $\Delta X_D(s)$

$$\Delta X_E(s) \left[1 + \frac{K_4 K_5}{s} \right] = \frac{-K_5 K_3}{s} [-K_1 K_c \Delta P_C(s) + K_2 \Delta f(s)]$$

$$\Delta X_E(s) = \frac{k_5 k_3 k_1 k_c (\Delta P_C(s) - \frac{k_2}{k_1 k_c} \Delta f(s))}{k_4 k_5 \left[1 + \frac{s}{k_4 k_5} \right]}$$

$$\Delta X_E(s) = \frac{K_3 K_1 K_C}{K_4} \frac{(\Delta P_C(s) - \frac{k_2}{k_1 k_c} \Delta f(s))}{\left[1 + \frac{s}{k_4 k_5} \right]}$$

$$K_G = \frac{K_3 K_1 K_C}{K_4} ; \quad T_G = \frac{1}{K_4 K_5} ; \quad \frac{1}{R} = \frac{k_2}{k_1 k_c} ;$$

Value of TG < 100 m sec

The equation can be written as:

$$\Delta X_E(s) = \left[\Delta P_C(s) - \frac{1}{R} \Delta f(s) \right] \times \frac{K_G}{1 + s T_G} \quad \dots\dots\dots (14)$$

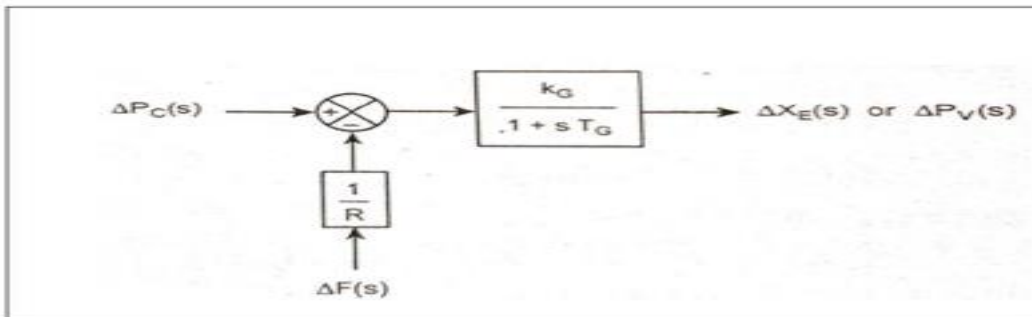

Fig.2 Model of speed governor