



DEPARTMENT OF BIOMEDICAL ENGINEERING

III Semester- BM3301 SENSORS AND MEASUREMENTS

UNIT - 2

2.2 Capacitive Transducer – Various Arrangements

The principle of operation of capacitive transducers is based upon the familiar equation for capacitance of a parallel plate capacitor.

Capacitance, $C = \frac{\epsilon A}{d}$

$$C = \frac{\epsilon_0 \epsilon_r A}{d}$$

where A = overlapping area of plates ; m²,

d = distance between two plates ; m,

$\epsilon = \epsilon_0 \epsilon_r$ = permittivity of medium; F/m

ϵ_r = relative permittivity

ϵ_0 = permittivity of free space

$$= 8.85 \times 10^{-12} \text{ F/m}$$

A parallel plate capacitor is shown in Figure 1

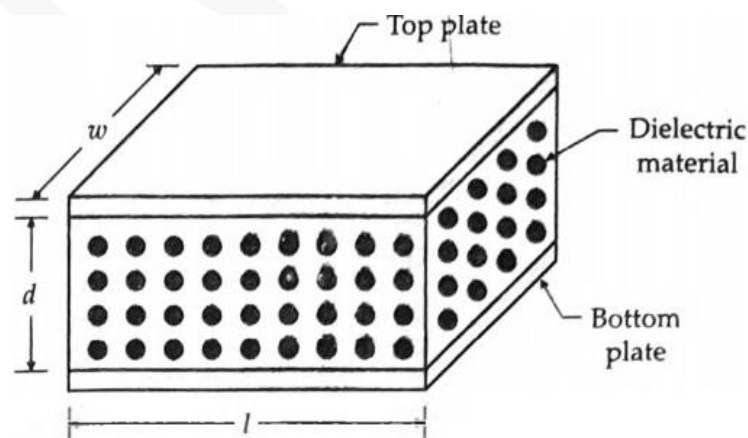

Figure 1: Schematic diagram of a parallel plate capacitive transducer.

As per its structure, these are having two parallel metal plates which are maintaining the distance between them. In between them, dielectric medium (such as air) can be filled. So, the distance between these two metal plates and positions of the plates can change the capacitance.

The capacitive transducer works on the principle of change of capacitance which may be caused by :

- (i) Change in overlapping area A,
- (ii) Change in the distance d between the plates, and
- (iii) Change in dielectric constant.

These changes are caused by physical variables like displacement, force and pressure in most of the cases. The change in capacitance may be caused by change in dielectric constant as is the case in measurement of liquid or gas levels. The capacitance may be measured with bridge circuits. The output impedance of a capacitive transducer is

$$X_c = \frac{1}{2\pi f C}$$

where C = capacitance and; f = frequency of excitation in Hz

In general, the output impedance of a capacitive transducer is high. The capacitive transducers are commonly used for measurement of linear displacement. These transducers use the following effects:

- (i) Change in capacitance due to change in overlapping area of plates, and
- (ii) Change in capacitance due to change in distance between the two plates.

2.2.1 Transducers Using Change in Area of Plates:

$$C = \frac{\epsilon A}{d}$$

- From the above equation, it is found that the capacitance is directly proportional to the area, A of the plates.
- Thus, the capacitance changes linearly with change in area of plates.
- Hence this type of capacitive transducer is useful for measurement of moderate to large displacements say from 1 mm to several centimetres.

The elementary diagrams of two types of capacitive transducers are shown in Figure 2(a) and 2(b).

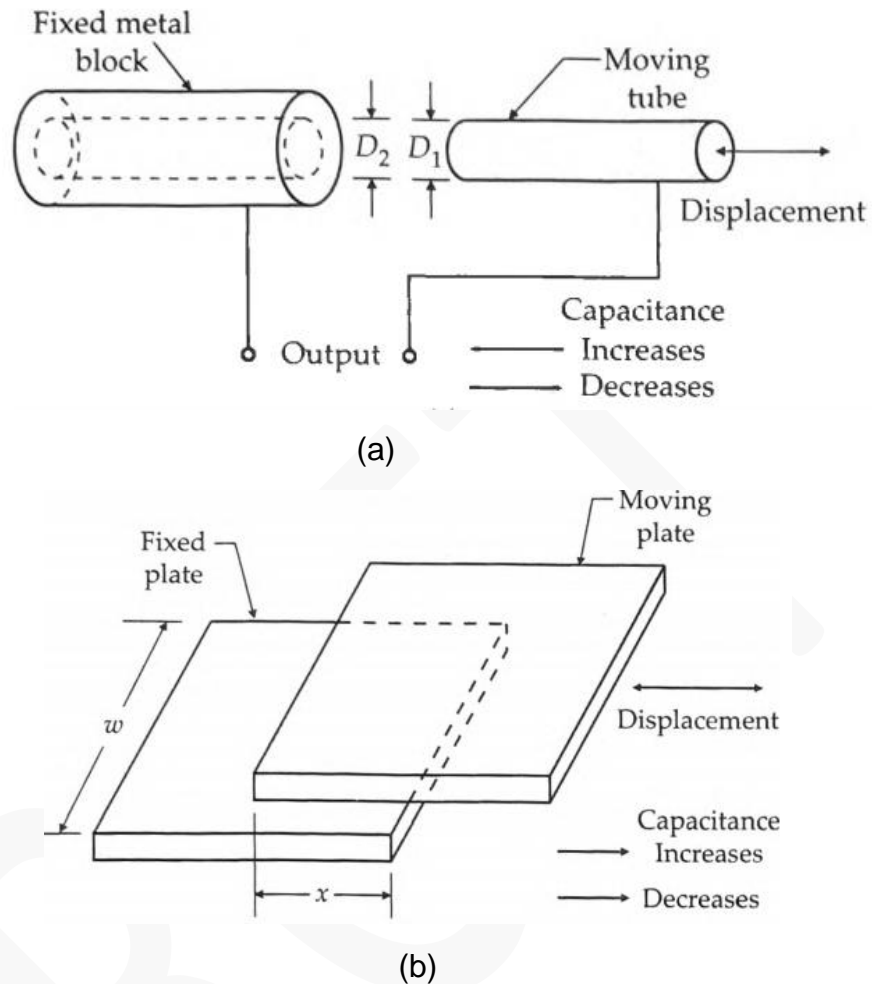

Figure.2 Capacitive transducers working on the principle of change of capacitance with change of area.

For a parallel plate capacitor, the capacitance is,

$$C = \frac{\epsilon A}{d}$$

$$= \frac{\epsilon x w}{d} \text{ F}$$

where x = length of overlapping part of plates ; m,
and w = width of overlapping part of plates ; m

The relationship between capacitance and displacement is linear as shown in Figure 3.

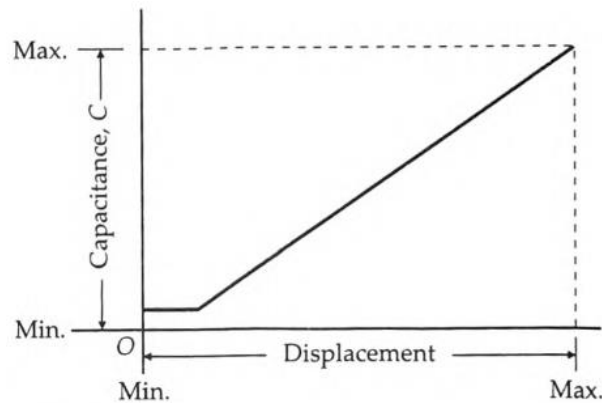

Figure 3. Capacitance displacement curve of capacitive transducer (working on principle of change of plate area caused by change in displacement).

Angular displacement measurement:

- The principle of change of capacitance with change in area can be employed for measurement of angular displacement.
- Figure 4 shows a two-plate capacitor. One plate is fixed and the other is movable. The angular displacement to be measured is applied to movable plate.
- The angular displacement changes the effective area between the plates and thus changes the capacitance.
- The capacitance is maximum when the two plates completely overlap each other i.e., when $\theta = 180^\circ$.

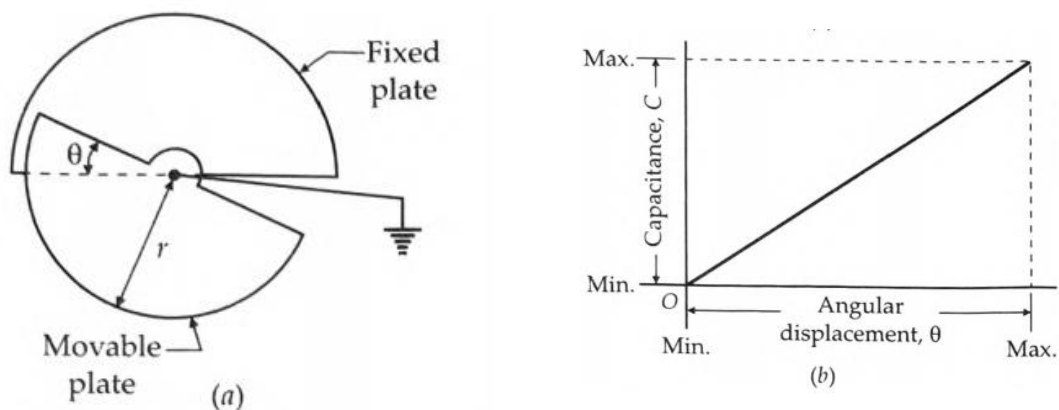

Figure 4. Capacitive transducer for measurement of angular displacement.

Maximum value of capacitance,

$$C_{max} = \frac{\epsilon A}{d} = \frac{\epsilon \pi r^2}{2d}$$

Capacitance at angle θ is,

$$C = \frac{\epsilon \theta r^2}{2d}$$

where θ = angular displacement in radian

Therefore, the variation of capacitance with angular displacement is linear. This is shown in Figure 4(b). capacitive transducer can be used for a maximum angular displacement of 180° .

2.2.2 Transducers Using Change in Distance between Plates:

Figure 5 (a) shows the basic form of a capacitive transducer utilizing the effect of change of capacitance with change in distance between the two plates.

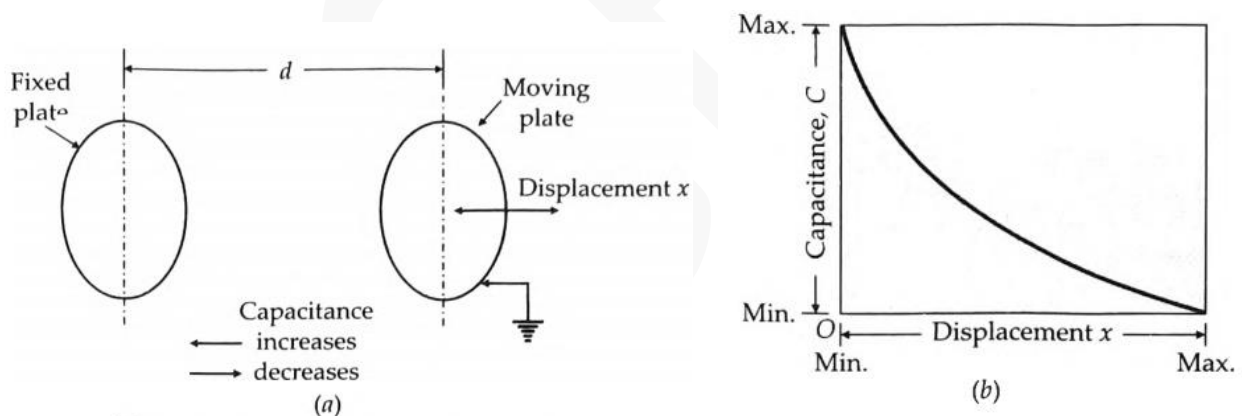

Figure 5. Capacitive transducer using the principle of change of capacitance with change of distance between plates.

- One is a fixed plate and the displacement to be measured is applied to the other plate which is movable.
- Since, the capacitance, C , varies inversely as the distance d ; between the plates.
- The response of this transducer is not linear and as shown in Figure 5(b).
- only approximately linear over a small range of displacement.

Figure 6 shows an arrangement for measurement of linear displacement. The displacement when applied to the cantilever type spring plate moves it towards the second plate decreasing the distance.

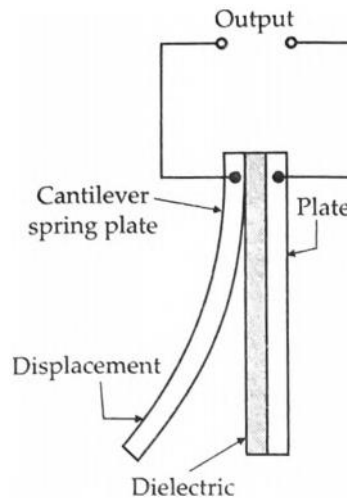

Figure 6. Capacitive transducer using cantilever spring plate

2.2.3 Variation of Dielectric Constant for Measurement of Displacement:

The third principle used in capacitive transducers is the variation of capacitance due to change in dielectric constant. *Figure 7* shows a capacitive transducer for measurement of linear displacement working on the above-mentioned principle. It has a dielectric of relative permittivity ϵ_r

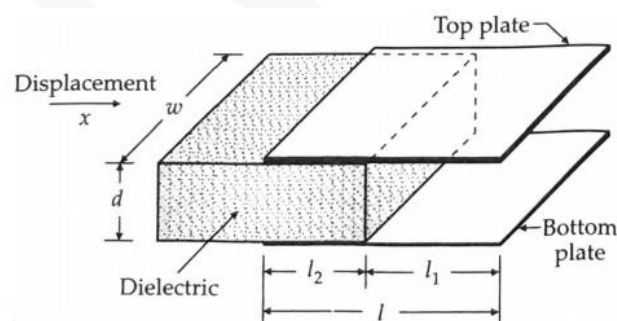

Figure .7: Capacitive transducer using principle of change in dielectric constant for measurement of displacement

2.2.4 Advantages of Capacitive Transducers:

The major advantages of capacitive transducers are,

- (i) They require extremely small forces to operate them
- (ii) They are extremely sensitive.
- (iii) They have a good frequency response.
- (iv) They have a high input impedance and therefore the loading effects are minimum.
- (v) A resolution of the order of 2.5×10^{-3} mm.

2.2.5 Disadvantages of Capacitive Transducers:

The principal disadvantages of capacitive transducers are

- (i) The metallic parts of the capacitive transducers must be insulated from each other. In order to reduce the effects of **stray capacitances**, the frames must be earthed.
- (ii) The capacitive transducers show **non-linear behaviour** many a times on account of edge effects. Therefore, guard rings must be used to eliminate this effect.
- (iii) The output impedance of capacitive transducers tends to be high on account to their small capacitance value. This leads to **loading effects**. The output impedance depends upon the frequency used.

2.2.6 Applications of Capacitive Transducers:

- (i) The capacitive transducers are used to measure humidity in gases.
- (ii) It is used to measure volume, liquid level, density etc.
- (iii) It is used for measurement of linear and angular displacement.
- (iv) Capacitive transducers can be used for the measurement of force and pressure