

3.3 POLAR PLOT

The polar plot of a sinusoidal transfer function $G(j\omega)$ is a plot of the magnitude $|G(j\omega)|$ versus the phase angle of $G(j\omega)$ on polar coordinates as ω is varied from zero to infinity. Thus, the polar plot is the locus of vectors $|G(j\omega)|$ as ω is varied from zero to infinity. The polar plot is also called Nyquist plot. It is a graphical method of determining stability of feedback control systems by using the polar plot of their open-loop transfer functions. Polar plot is a plot to be drawn between magnitude and phase. Polar plot is a plot of magnitude of $G(j\omega)$ versus the phase of $G(j\omega)$ in polar co-ordinates. But the magnitudes are presented with normal values only. The Polar plot is a plot, which can be drawn between the magnitude and the phase angle of $G(j\omega)$ $H(j\omega)$ by differentiating g ω from zero to ∞ . The polar graph sheet is described in below mentioned image. This graph sheet includes various concentric circles and radial lines. The concentric circles and the radial lines are considered as the magnitudes and phase angles.

- Angles are highlighted with positive values in anti-clock wise direction.
- Mark angles with negative values in clockwise direction.

The polar plot is usually plotted on a polar graph sheet. The polar graph sheet has concentric circles and radial lines. The circles represent the magnitude and the radial lines represent the phase angles. Each point on the polar graph has a magnitude and phase angle. The magnitude of a point is given by the value of the circle passing through that point and the phase angle is given by the radial line passing through that point. In polar graph sheet a positive phase angle is measured in anticlockwise from the reference axis (0°) and a negative angle is measured clockwise from the reference axis (0°). In order to plot the polar plot, magnitude and phase of $G(j\omega)$ are computed for various values of ω and tabulated. Usually the choice of frequencies are corner frequencies and frequencies around corner frequencies. Choose proper scale for the magnitude circles. Fix all the points on polar graph sheet and join the points by smooth curve, write the frequency corresponding to each point of the plot. Alternatively, if $G(j\omega)$ can be expressed in rectangular coordinates as,

$$G(j\omega) = G_R(j\omega) + jG_I(j\omega)$$

where, $G_R(j\omega)$ = Real part of $G(j\omega)$, $G_I(j\omega)$ = Imaginary part of $G(j\omega)$

Then the polar plot can be plotted in ordinary graph sheet between $G_R(j\omega)$ and $G_I(j\omega)$ by varying ω from 0 to infinity. In order to plot the polar plot on ordinary graph sheet, the magnitude and phase of $G(j\omega)$ are computed for various values of ω . Then convert the polar coordinates to rectangular coordinates using $P \rightarrow R$ conversion (polar to rectangular conversion) in the calculator. Sketch the polar plot using rectangular coordinates. For minimum phase transfer function with only poles, type number of the system determines the quadrant at which the polar plot starts and the order of the system determines quadrant at which the polar plot ends. The minimum phase systems are systems with all poles and zeros on left half of s-plane. The start and end of polar plot of all pole minimum phase system are shown in figures respectively. Some typical sketches of polar plot are shown in table. The change in shape of polar plot can be predicted due to addition of a pole or zero.

1. When a pole is added to s system, the polar plot end point will shift by -90° .
2. When a zero is added to s system, the polar plot end point will shift by $+90^\circ$.

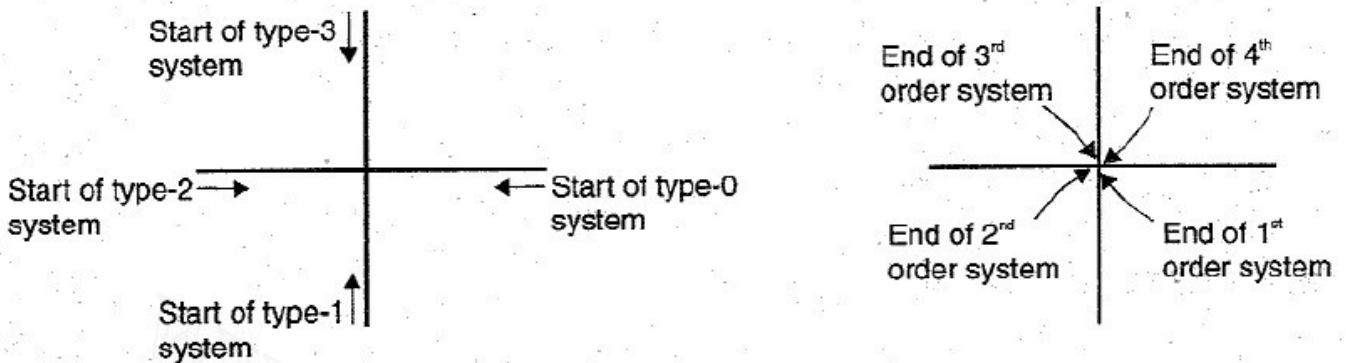

Figure 3.3.1 Start and end of polar plot of all pole minimum phase system

[Source: "Control Systems" by A Nagoor Kani, Page: 3.38]

RULES FOR DRAWING POLAR PLOT

- ✓ Substitute, $s=j\omega$ in the open loop transfer function.
- ✓ Write the expressions for magnitude and the phase of $G(j\omega) H(j\omega)$.
- ✓ Find the starting magnitude and the phase of $G(j\omega) H(j\omega)$ by substituting $\omega=0$. So, the polar plot starts with this magnitude and the phase angle.
- ✓ Find the ending magnitude and the phase of $G(j\omega) H(j\omega)$ by substituting $\omega=\infty$. So, the polar plot ends with this magnitude and the phase angle.
- ✓ Check whether the polar plot intersects the real axis, by making the imaginary term of $G(j\omega) H(j\omega)$ equal to zero and find the value(s) of ω .

- ✓ Check whether the polar plot intersects the imaginary axis, by making real term of $G(j\omega) H(j\omega)$ equal to zero and find the value(s) of ω .
- ✓ For drawing polar plot more clearly, find the magnitude and phase of $G(j\omega) H(j\omega)$ by considering the other value(s) of ω .

DETERMINATION OF GAIN MARGIN AND PHASE MARGIN FROM POLAR PLOT

The gain margin is defined as the inverse of the magnitude of $G(j\omega)$ at phase crossover frequency. The phase crossover frequency is the frequency at which the phase of $G(j\omega)$ is 180° . Let the polar plot cut the 180° axis at point B and the magnitude circle passing through the point B be G_B . Now the gain margin, $K_g = 1/G_B$. If the point B lies within unity circle, the gain margin is positive otherwise negative. If the polar plot is drawn in ordinary graph sheet using rectangular coordinates then the point B is the cutting point of $G(j\omega)$ locus with negative real axis and $K_g = 1/|G_B|$ where G_B is the magnitude corresponding to point B). The phase margin is defined as, phase margin, $\gamma = 180^\circ + \Phi_{gc}$ is the phase angle of $G(j\omega)$ at gain crossover frequency. The gain crossover frequency is the frequency at which the magnitude of $G(j\omega)$ is unity. Let the polar plot cut the unity circle at point A as shown in figures. Now the phase margin, γ is given by $\angle AOP$, i.e., $\angle AOP$ is below -180° axis then the phase margin is positive and if it is above -180° axis then the phase margin is negative.

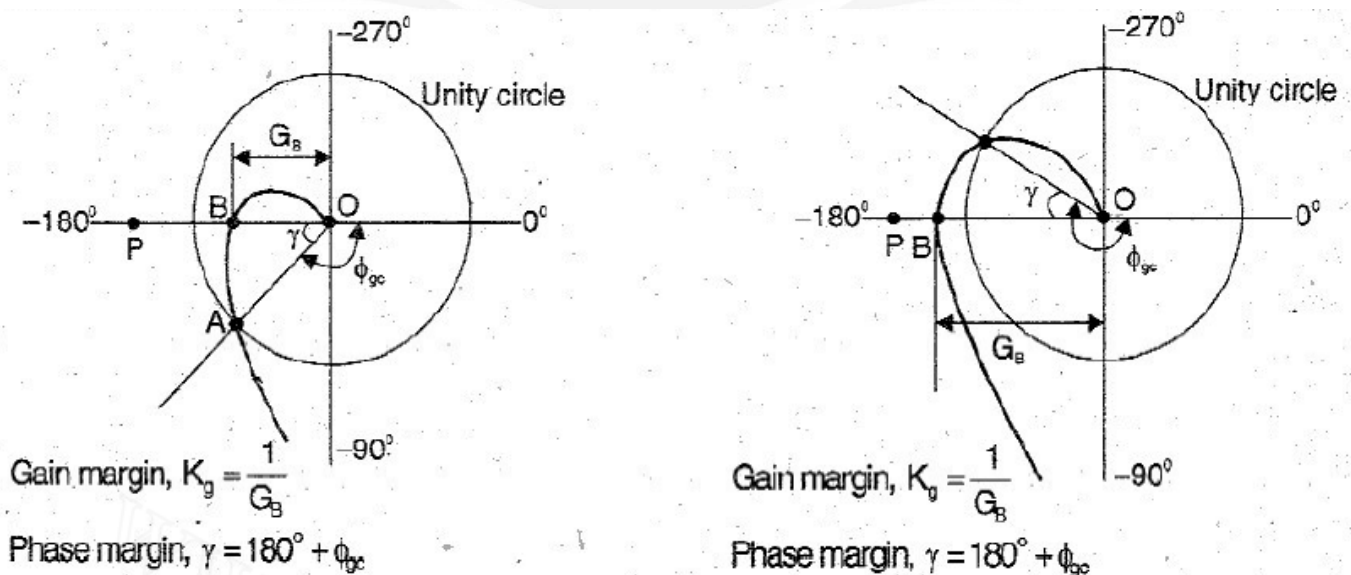

Figure 3.3.2 Polar plot with positive and negative gain and phase margins

[Source: "Control Systems" by A Nagoor Kani, Page: 3.41]

GAIN ADJUSTMENT USING POLAR PLOT

To determine K for specified GM

Draw $G(j\omega)$ locus with $K = 1$. Let it cut the -180° axis at point B corresponding to gain of G_B . Let the specified gain margin be x db. For this gain margin, the $G(j\omega)$ locus will cut -180° at point A whose magnitude is G_A .

$$20 \log \frac{1}{G_A} = x$$

$$\log \frac{1}{G_A} = \frac{x}{20}$$

$$\frac{1}{G_A} = 10^{\frac{x}{20}}$$

$$G_A = \frac{1}{10^{\frac{x}{20}}}$$

Now the value of K is given by, $K = G_A/G_B$

If, $K > 1$, then the system gain should be increased.

If $K < 1$, then the system gain should be reduced.

To determine K for specified PM

Draw $G(j\omega)$ locus with $K = 1$. Let it cut the unity circle at point B. (The gain at point B is G_B and equal to unity). Let the specified phase margin be x° . For a phase margin of x° , let Φ_{gcx} be the phase angle of $G(j\omega)$ at gain crossover frequency.

$$x^\circ = 180^\circ + \Phi_{gcx}$$

$$\Phi_{gcx} = x^\circ - 180^\circ$$

In the polar plot, the radial line corresponding to Φ_{gcx} will cut the locus of $G(j\omega)$ with $K = 1$ at point A and the magnitude corresponding to that point be G_A .

$$\text{Now, } K = G_B/G_A = 1/G_A \text{ (since } G_B = 1)$$