

3.3.FULL WAVE RECTIFIER

Full wave rectifier rectifies the full cycle in the waveform i.e. it rectifies both the positive and negative cycles in the waveform. We have already seen the characteristics and working of Half Wave Rectifier. This Full wave rectifier has an advantage over the half wave i.e. it has average output higher than that of half wave rectifier. The number of AC components in the output is less than that of the input.

The full wave rectifier can be further divided mainly into following types.

- Center Tapped Full Wave Rectifier
- Full Wave Bridge Rectifier

Centre-Tap Full Wave Rectifier

We have already discussed the Full Wave Bridge Rectifier, which uses four diodes, arranged as a bridge, to convert the input alternating current (AC) in both half cycles to direct current (DC).

In the case of centre-tap full wave rectifier, only two diodes are used, and are connected to the opposite ends of a centre-tapped secondary transformer as shown in the figure below. The centre-tap is usually considered as the ground point or the zero voltage reference point.

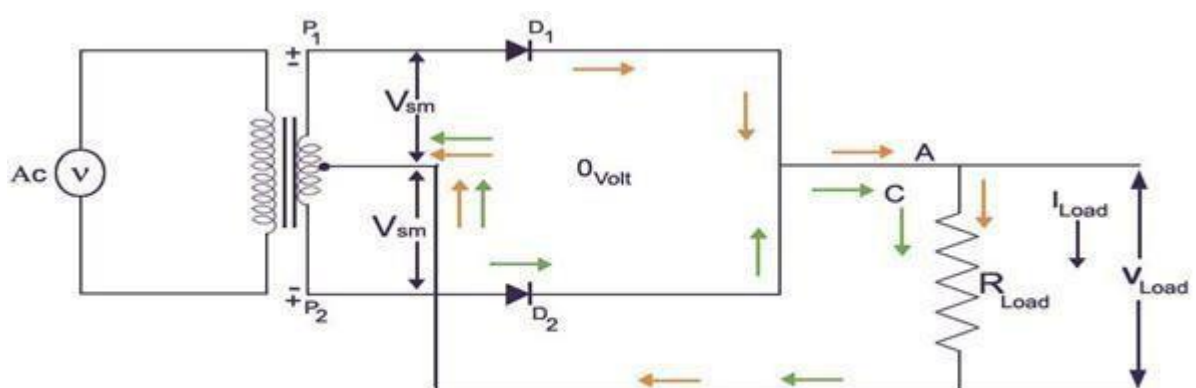

CENTRE - TAP FULL- WAVE RECTIFIER CIRCUIT

Figure: 1.4.1 Centre Tap Full Wave Rectifier Circuit

[Source: "Electronic devices and circuits" by "Balbir Kumar, Shail.B.Jain, and Page: 268]

EE 3501- POWER ELECTRONICS

Working of Centre-Tap Full Wave Rectifier

As shown in the figure, an ac input is applied to the primary coils of the transformer. This input makes the secondary ends P1 and P2 become positive and negative alternately.

For the positive half of the ac signal, the secondary point D1 is positive, GND point will have zero volt and P2 will be negative.

At this instant diode D1 will be forward biased and diode D2 will be reverse biased.

As explained in the Theory behind P-N Junction and Characteristics of P-N Junction Diode, the diode D1 will conduct and D2 will not conduct during the positive half cycle. Thus the current flow will be in the direction P1-D1-C-A-B-GND. Thus, the positive half cycle appears across the load resistance RLOAD.

During the negative half cycle, the secondary ends P1 becomes negative and P2 becomes positive. At this instant, the diode D1 will be negative and D2 will be positive with the zero reference point being the ground, GND. Thus, the diode D2 will be forward biased and D1 will be reverse biased. The diode D2 will conduct and D1 will not conduct during the negative half cycle. The current flow will be in the direction P2-D2-C-A-B-GND.

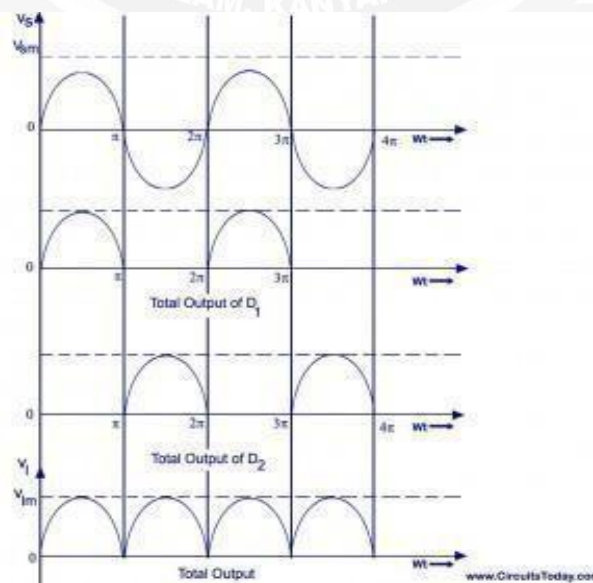

Figure: 1.4.2 Centre-tap Full-wave Rectifier-Waveform

[Source: "Electronic devices and circuits" by "Balbir Kumar, Shail.B.Jain, and Page: 268]

When comparing the current flow in the positive and negative half cycles, we can conclude that the direction of the current flow is the same (through load resistance RLOAD). When compared to the Half-Wave Rectifier, both the half cycles are used to produce the corresponding output.

The frequency of the rectified output voltage is twice the input frequency. The output that is rectified, consists of a dc component and a lot of ac components of minute amplitudes.

Peak Inverse Voltage (PIV) of Centre-Tap Full Wave Rectifier

PIV is the maximum possible voltage across a diode during its reverse biased period. Let us analyze the PIV of the Centre-tapped rectifier from the circuit diagram. During the first half or the positive half of the input ac supply, the diode D1 is positive and thus conducts and provided no resistance at all. Thus, the whole of voltage Vs developed in the upper-half of the ac supply is provided to the load resistance RLOAD.

- **Peak Current**

The instantaneous value of the voltage applied to the rectifier can be written as

$$V_s = V_{sm} \sin \omega t$$

Assuming that the diode has a forward resistance of R_{FWD} ohms and a reverse resistance equal to infinity, the current flowing through the load resistance RLOAD is given as

$$I_m = V_{sm} / (R_F + R_{Load})$$

- **Output Current**

Since the current is the same through the load resistance R_L in the two halves of the ac cycle, magnitude of dc current I_{dc}, which is equal to the average value of ac current, can be obtained by integrating the current i₁ between 0 and π or current i₂ between π

$$I_{dc} = 1/\pi \int_0^{\pi} i_1 d(\omega t) = 1/\pi \int_0^{\pi} I_{max} \sin \omega t d(\omega t) = 2I_m/\pi$$

Output current of Centre Tap rectifier

- **DC Output Voltage**

Average or dc value of voltage across the load is given as

$$I_{dc} = 1/\pi \int_0^{\pi} i_1 d(\omega t) = 1/\pi \int_0^{\pi} I_{max} \sin \omega t d(\omega t) = 2I_m/\pi$$

DC Output Voltage of center Tap Rectifier

- **Root Mean Square (RMS) Value of Current**

RMS or effective value of current flowing through the load resistance R_L is given as

$$I_{rms}^2 = 1/\pi \int_0^{\pi} i^2 d(\omega t) = I_m^2/2 \text{ or } I_{rms} = I_m/\sqrt{2}$$

