

UNIT IV

FUEL CELL

Hydrocarbon air cell

A hydrocarbon–air fuel cell is an electrochemical device that **converts the chemical energy of hydrocarbon fuels** (such as methane, methanol, propane, etc.) **and oxygen from air** directly into **electrical energy**.

Types of Hydrocarbon Fuel Cells

1. Direct Methanol Fuel Cell (DMFC):

- Uses methanol directly
- Suitable for portable devices

2. Solid Oxide Fuel Cell (SOFC):

- Operates at high temperature (700–1000°C)
- Can use natural gas, methane

3. Molten Carbonate Fuel Cell (MCFC):

- Uses natural gas or biogas
- Suitable for power plants

Description

- ❖ Fuel –Hydrocarbon
- ❖ Oxidant – O₂

Principle

- It works on the principle of **electrochemical oxidation–reduction (redox) reactions**.
- Hydrocarbon is oxidized at the anode.
- **Oxygen from air** is reduced at the cathode.
- Electrons flow through the external circuit, producing electricity.

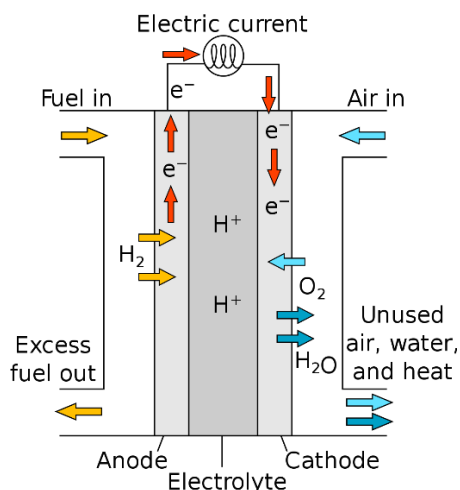

Working:

Solid Oxide Fuel Cell (SOFC):

- Solid ceramic material is used as an electrolyte.
- It conducts oxide ions (O^{2-}).
- It operates at high temperature(700-1000°C)

At Anode:

- Methane reacts with oxygen ions:



At Cathode:

- Oxygen from air gains electrons

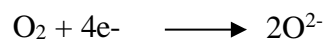

Over all Reaction

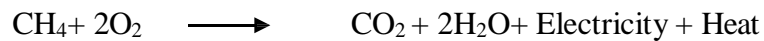

Molten Carbonate Fuel Cell (MCFC):

- Molten mixture of lithium, sodium, or potassium carbonates is used as an electrolyte.
- It Conducts carbonate ions (CO_3^{2-}).
- It operates at 600-700°C.

At Anode:



At Cathode:

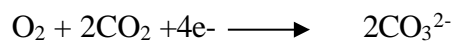

Over all Reaction

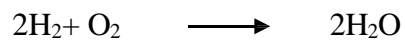

Advantages

- Uses easily available fuels (natural gas, methanol)
- No need for hydrogen storage
- High efficiency (especially SOFC)
- Continuous power generation
- Suitable for large-scale power production

Disadvantages

- Produces CO₂ (not completely pollution-free)
- High operating temperature (SOFC)
- Expensive materials
- Slow start-up time
- Carbon deposition (coking) problem

Applications

- Stationary power plants
- Industrial power generation
- Backup power systems
- Portable electronic devices (DMFC)