

1.3 PERFORMANCE CHARACTERISTICS OF OP-AMP

Current is taken from the source into the op-amp inputs respond differently to current and voltage due to mismatch in transistor.

DC output voltages are,

- Input bias current
- Input offset current
- Input offset voltage
- Thermal drift

INPUT BIAS CURRENT

The op-amp's input is differential amplifier, which may be made of BJT or FET. In an ideal op-amp, we assumed that no current is drawn from the input terminals the base currents entering into the inverting and non-inverting terminals (I_B^- & I_B^+ respectively). Even though both the transistors are identical, I_B^- and I_B^+ are not exactly equal due to internal imbalance between the two inputs. Input bias current and Inverting amplifier with bias currents is shown in figure 1.3.1. Manufacturers specify the input bias current I_B

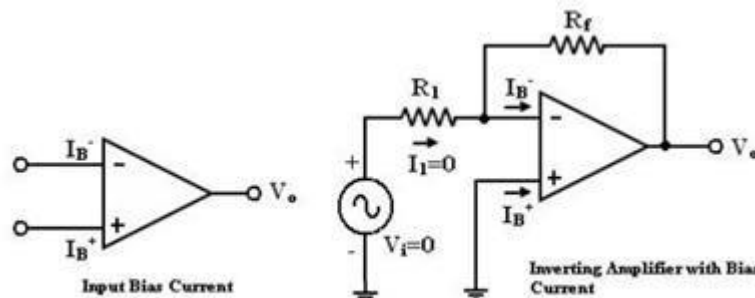

Figure 1.3.1 a) input bias current b) Inverting amplifier with bias currents

[source: "Linear Integrated Circuits" by D.Roy Choudhry, Shail Bala Jain, Page-118]

$$I_B = \frac{I_B^+ + I_B^-}{2}$$

If input voltage $V_i = 0V$. The output Voltage V_o should also be ($V_o = 0$) but for $I_B = 500nA$ We find that the output voltage is offset by Op-amp with a 1M feedback resistor

$$V_o = 500nA \times 1M = 500mV$$

The output is driven to 500mV with zero input, because of the bias currents.

In application where the signal levels are measured in mV, this is totally unacceptable. This can be compensated by a compensation resistor R_{comp} has been added between the non-inverting input terminal and ground as shown in the figure 1.3.2 below.

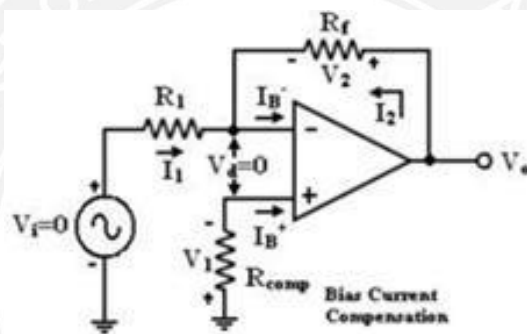

Figure 1.3.2 Bias compensated circuit in non-inverting amplifier

[source: "Linear Integrated Circuits" by D.Roy Choudhry, Shail Bala Jain, Page-119]

Current I_B^+ flowing through the compensating resistor R_{comp} , then by KVL we get,

$$-V_1 + 0 + V_2 - V_o = 0 \text{ (or)}$$

$$V_o = V_2 - V_1 \text{----- (1)}$$

By selecting proper value of R_{comp} , V_2 can be cancelled with V_1 and the $V_o = 0$. The value of R_{comp} is derived as

$$V_1 = I_B^+ R_{comp} \text{ (or)}$$

$$I_B^+ = V_1 / R_{comp} \text{----- (2)}$$

The node 'a' is at voltage ($-V_1$). Because the voltage at the non-inverting input terminal is ($-V_1$).

So with $V_i = 0$ we get,

$$I_1 = V_1/R_1 \quad (3)$$

$$I_2 = V_2/R_f \quad (4)$$

For compensation, V_o should equal to zero ($V_o = 0$, $V_i = 0$). i.e. from equation (3) $V_2 = V_1$. So that,

$$I_2 = V_1/R_f \longrightarrow (5)$$

KCL at node 'a' gives,

$$I_B^- = I_2 + I_1 = (V_1/R_f) + (V_1/R_1) = V_1(R_1 + R_f)/R_1 R_f \quad (5)$$

Assume $I_B^- = I_B^+$ and using equation (2) & (5) we get

$$V_1 (R_1 + R_f)/R_1 R_f = V_1/R_{comp}$$

$$R_{comp} = R_1 \parallel R_f \quad (6)$$

i.e. to compensate for bias current, the compensating resistor, R_{comp} should be equal to the parallel combination of resistor R_1 and R_f .

INPUT OFFSET CURRENT

- i. Bias current compensation will work if both bias currents I_B^+ and I_B^- are equal.
- ii. Since the input transistor cannot be made identical. There will always be some small difference between I_B^+ and I_B^- . This difference is called the offset current

$$|I_{os}| = I_B^+ - I_B^- \quad (7)$$

Offset current I_{os} for BJT op-amp is 200nA and for FET op-amp is 10pA. Even with bias current compensation, offset current will produce an output voltage when $V_i = 0$.

$$V_1 = I_B^+ R_{comp} \quad (11)$$

$$\text{And } I_1 = V_1/R_1 \quad (12)$$

KCL at node a gives,

$$I_2 = (I_B^- - I_1) = I_B^- - (I_B^+ \frac{R_{comp}}{R_1})$$

Output voltage $V_o = R_f I_{os}$

Again $V_o = I_2 R_f - V_1$

$$V_o = I_2 R_f - I_B^+ R_{comp}$$

$$V_o = 1M \Omega \times 200nA$$

$$V_o = 200mV \text{ with } V_i = 0$$

By using the above Equation the offset current can be minimized by keeping feedback resistance small.

- Unfortunately to obtain high input impedance, R_1 must be kept large.
- R_1 large, the feedback resistor R_f must also be high. So as to obtain reasonable gain.

The T-feedback network is a good solution. This will allow large feedback resistance, while keeping the resistance to ground low (in dotted line).

The T-network provides a feedback signal as if the network were a single feedback resistor.

By T to Π conversion,

$$R_f = \frac{R_t^2 + 2R_t R_s}{R_s}$$

To design T- network first pick $R_t \ll R_f/2$ and calculate

$$R_s = \frac{R_t^2}{R_f - 2R_t}$$

INPUT OFFSET VOLTAGE

In spite of the use of the above compensating techniques, it is found that the output voltage may still not be zero with zero input voltage [$V_o \neq 0$ with $V_i = 0$]. This is due to unavoidable imbalances inside the op-amp and one may have to apply a small voltage at the input terminal to make output (V_o) = 0. figure 1.3.3 a) shown below is the op-amp showing input offset voltage. This voltage is called input offset voltage V_{os} . This is the voltage required to be applied at the input for making output voltage to zero ($V_o = 0$).

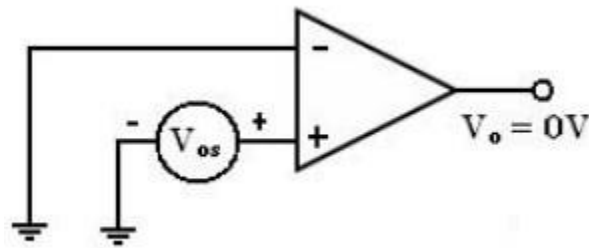

Figure 1.3.3 a) op-amp showing input offset voltage

[source: "Linear Integrated Circuits" by D.Roy Choudhry, Shail Bala Jain, Page-121]

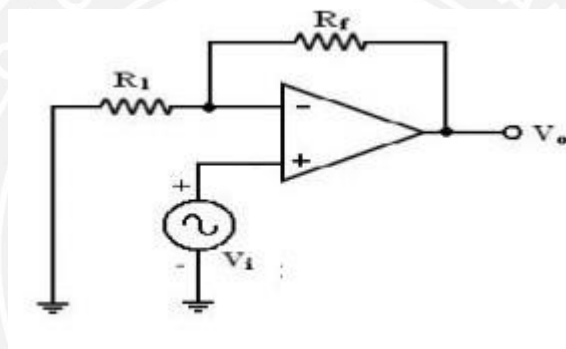

Figure 1.3.3 b) Non-inverting Amplifier

[source: "Linear Integrated Circuits" by D.Roy Choudhry, Shail Bala Jain, Page-122]

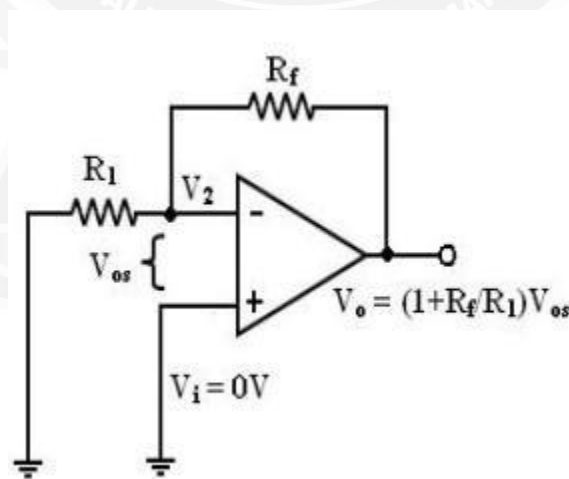

Figure 1.3.3c) Inverting Amplifier

[source: "Linear Integrated Circuits" by D.Roy Choudhry, Shail Bala Jain, Page-122]

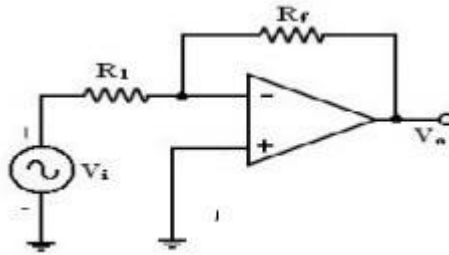

Figure 1.3.3 d) Equivalent circuit for $V_i=0$

[source: "Linear Integrated Circuits" by D.Roy Choudhry, Shail Bala Jain, Page-122]

Let us determine the V_{os} on the output of inverting and non-inverting amplifier. If $V_i = 0$ (Figure 1.3.3(b) and 1.3.3 (c)) become the same as in figure 1.3.3(d).

TOTAL OUTPUT OFFSET VOLTAGE

The total output offset voltage V_{OT} could be either more or less than the offset voltage produced at the output due to input bias current (I_B) or input offset voltage alone (V_{os}). This is because I_B and V_{os} could be either positive or negative with respect to ground. Therefore the maximum offset voltage at the output of an inverting and non-inverting amplifier (figure 1.3.3 b, c) without any compensation technique used is given by many op amps provide offset compensation pins to nullify the offset voltage. A 10K potentiometer is placed across offset null pins 1 & 5. The wiper is connected to the negative supply at pin 4. The position of the wiper is adjusted to nullify the offset voltage. Compensation circuit for offset voltage is shown in figure 1.3.4.

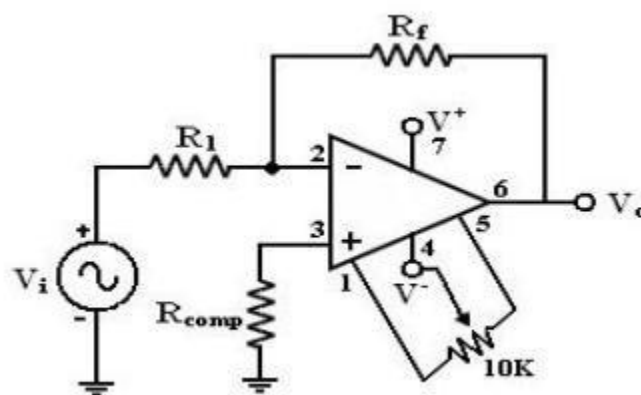

Figure 1.3.4. compensation circuit for offset voltage

[source: "Linear Integrated Circuits" by D.Roy Choudhry, Shail Bala Jain, Page-123]

When the given (below) op-amps does not have these offset null pins, external balancing techniques are used.

$$V_{OT} = \left(1 + \frac{R_f}{R_1}\right) V_{OS} + R_f I_B$$

With Rcomp, the total output offset

$$V_{OT} = \left(1 + \frac{R_f}{R_1}\right) V_{OS} + R_f I_{OS}$$

THERMAL DRIFT

Bias current, offset current, and offset voltage change with temperature. A circuit carefully nulled at 25°C may not remain. So when the temperature rises to 35°C. This is called drift. Offset current drift is expressed in nA/°C. These indicate the change in offset for each degree Celsius change in temperature.