

TORSIONAL STRESS AND DEFORMATION

1.8. Torsional Stress and Deformations

Shear stress is produced about a longitudinal axis of a structural member by the application of twisting couple to the end of the structural member is known as

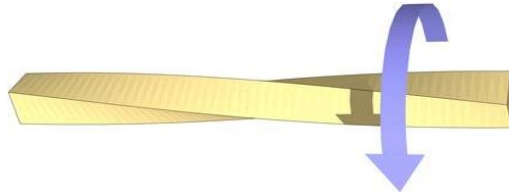

torsional stress. Torsion is the twisting of a straight bar when it is loaded by twisting couple or torque. It tends to produce rotation about the longitudinal axes of the bar.

For instant, when we turn a screw driver to produce torsion our hand applies torque “ T ” to the handle and twist the shank of the screw driver.

1.8.1. TORSIONAL PENDULUM

When a body is fixed at one end and twisted about its axis by means of a torque at the other end, then the body is said to be under torsion. The torsion involves shearing strain and hence modulus involved is the rigidity modulus.

Torsional pendulum consists of a suspension wire with one end is fixed and the other end is fixed to the center of the circular disc. Let l be the length of the suspension wire and r be the radius of the suspension wire. When a heavy circular disc is rotated in a horizontal plane, so that the wire is twisted through an angle θ . The various elements of the wire will undergo shearing strain and restoring couple is produced. Now if the disc is released, the disc will produce torsional oscillations. The couple acting on the disc produces an angular acceleration in it, which is proportional to the angular displacement and is always directed towards its mean position.

Total energy of the torsion pendulum = P.E + K.E

The potential energy confined to the wire is equal to the work done in twisting the disc, thereby creating a restoring couple (C).

The restoring couple through an angle $\theta = \int_0^{\theta} \text{moment of couple} \times d\theta$

$$= \int_0^\theta C\theta d\theta = \frac{C\theta^2}{2} \dots\dots\dots (8)$$

Let ω be the angular velocity with which the disc oscillates, due to the restoring couple, then

The kinetic energy of the rotating disc (deflecting couple) = $\frac{I\omega^2}{2}$ (9)

I be the moment of inertia of the circular disc

Total energy = $\frac{C\theta^2}{2} + \frac{I\omega^2}{2} = \text{constant}$ (10)

Differentiating equation (4) with respect to ‘t’ we get,

$$C\theta \frac{d\theta}{dt} + I\omega \frac{d\omega}{dt} = 0 \dots\dots\dots (11)$$

Since the angular velocity $\omega = \frac{d\theta}{dt}$ and the angular acceleration $\frac{d\omega}{dt} = \frac{d^2\theta}{dt^2}$

∴ Equation (11) becomes

$$C\theta \frac{d\theta}{dt} + I \frac{d\theta}{dt} \frac{d^2\theta}{dt^2} = 0$$

$$\frac{d\theta}{dt} \left[C\theta + I \frac{d^2\theta}{dt^2} \right] = 0$$

Here $\frac{d\theta}{dt} \neq 0$ ∴ $\left[C\theta + I \frac{d^2\theta}{dt^2} \right] = 0$

∴ Angular acceleration = $\frac{d^2\theta}{dt^2} = -\frac{C\theta}{I}$ (12)

The negative sign indicates that the couple tends to decrease the twist on the wire.

TIME PERIOD OF TORSIONAL OSCILLATION

The time period of torsional oscillation $T = 2\pi \frac{\text{angular displacement}}{\text{angular acceleration}}$

$$T = 2\pi \sqrt{\frac{\theta}{C\theta/I}} = 2\pi \sqrt{\frac{I}{C}} \dots\dots\dots (13)$$

Frequency of oscillation $f = \frac{1}{T} = \frac{1}{2\pi} \sqrt{\frac{C}{I}}$ (14)

1.8.2. RIGIDITY MODULUS OF THE WIRE

Let l be the length of the suspension wire and r be the radius of the suspension wire. We know

The twisting couple per unit angular twist of the wire $C = \frac{1}{2} \frac{n\pi r^4}{l}$ (15)

Substituting equation (9) in equation (7) we get

$$T = 2\pi \sqrt{\frac{I}{n\pi r^4 / 2l}} = 2\pi \sqrt{\frac{2Il}{n\pi r^4}}$$

$$T^2 = 4\pi^2 \frac{2Il}{n\pi r^4} = \frac{8\pi Il}{nr^4}$$

Rigidity modulus of the wire $n = \frac{8\pi Il}{T^2 r^4}$

..... (16)

Thus torsional pendulum is used to find the rigidity modulus of the various materials.

Experimental verification of torsional pendulum

A torsion pendulum is constructed as shown in Figure.

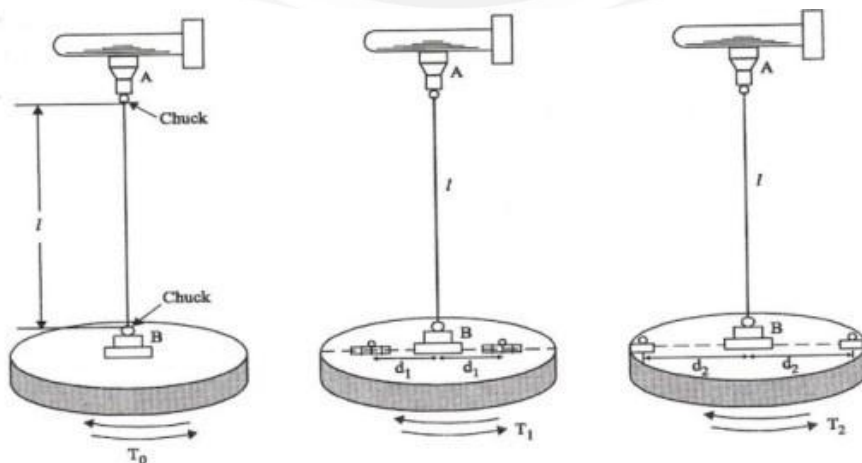

Fig.1.8.1.2 Torsion pendulum

Measure carefully the length of the suspension wire between the two chucks. Standing in front of the pendulum, gently set it in torsional oscillation without any lateral movement.

Note the time for 10 oscillations. T_0 , the period of oscillation of the pendulum without any masses in it calculated. Take two readings. Find the mean.

Two equal symmetrical masses (m) are placed on the disc on either side, close to the suspension wire. The closest distance ' d_1 ' from the center of the symmetrical mass and the center of the suspension wire is found. Set the pendulum to oscillate and note the time for 10 oscillations. From that the period of oscillation T_1 is calculated. Take two readings find the mean.

Two equal masses are now moved to the extreme ends so that the edges of masses coincide with the edge of the disc and the centers are equaled distant. The distance ' d_2 ' from the center of the symmetrical mass and the center of the suspension wire is noted. Set the pendulum to oscillate and note the time for 10 oscillations. Take two readings. Calculate the mean period of oscillation T_2 . All the measured parameters are tabulated in the given table,

Position of the Symmetrical masses	Time taken for 10 oscillations			Time period	Square of the time period
	Trail 1	Trail 2	Mean		
Unit	s	s	s	s	s
Without any Masses				$T_0 =$	$T_0^2 =$
With masses at closest distance $d_1 = \dots \times 10^{-2} \text{ m}$				$T_1 =$	$T_1^2 =$
With masses at farther distance $d_2 = \dots \times 10^{-2} \text{ m}$				$T_2 =$	$T_2^2 =$

Measure carefully, the diameter ($2r$) of the wire at various places, with a screw gauge. Find the mean of the diameter and calculate the radius. Note the mass (m) of the one symmetrical mass. The moment of inertia of the disc and rigidity modulus of the wire is calculated using the formula

$$\eta = \frac{8\pi I l}{T^2 r^4}$$