

5.2 EFFECT OF LAG, LEAD AND LAG-LEAD COMPENSATION ON FREQUENCY RESPONSE

Every control system which has been designed for a specific application should meet certain performance specification. There are always some constraints which are imposed on the control system design in addition to the performance specification. The choice of a plant is not only dependent on the performance specification but also on the size, weight & cost. Although the designer of the control system is free to choose a new plant, it is generally not advised due to the cost & other constraints. Under this circumstance, it is possible to introduce some kind of corrective sub-systems in order to force the chosen plant to meet the given specification. We refer to these sub-systems as compensator whose job is to compensate for the deficiency in the performance of the plant.

Necessary of Compensation

1. In order to obtain the desired performance of the system, we use compensating networks. Compensating networks are applied to the system in the form of feed forward path gain adjustment.
2. Compensate a unstable system to make it stable.
3. A compensating network is used to minimize overshoot.
4. These compensating networks increase the steady state accuracy of the system. An important point to be noted here is that the increase in the steady state accuracy brings instability to the system.
5. Compensating networks also introduces poles and zeros in the system thereby causes changes in the transfer function of the system. Due to this, performance specifications of the system change.

EFFECT OF LAG COMPENSATION ON FREQUENCY RESPONSE

The Lag Compensator is an electrical network which produces a sinusoidal output having the phase lag when a sinusoidal input is applied. The lag compensator circuit in the 's' domain is shown in the following figure.

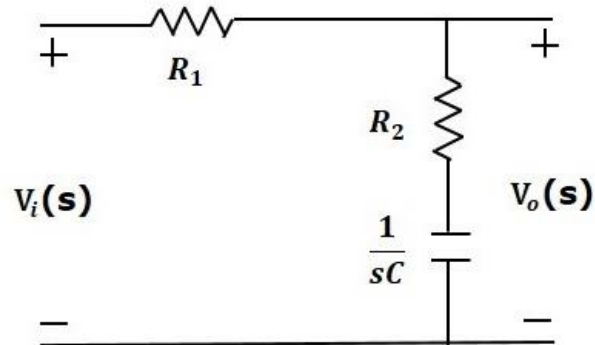

Figure 5.2.1 Electrical lag compensator

[Source: "Control Systems" by A Nagoor Kani, Page: 4.65]

Here, the capacitor is in series with the resistor R_2 and the output is measured across this combination. The transfer function of this lag compensator is

$$\frac{V_o(s)}{V_i(s)} = \frac{1}{\beta} \left(\frac{s + \frac{1}{\tau}}{s + \frac{1}{\beta\tau}} \right)$$

$$\tau = R_2 C$$

$$\beta = \frac{R_1 + R_2}{R_2}$$

$$\beta > 1$$

$$\text{Pole, } s = -\frac{1}{\beta\tau}$$

$$\text{Zero, } s = -\frac{1}{\tau}$$

Let $s = j\omega$,

$$\frac{V_o(j\omega)}{V_i(j\omega)} = \frac{1}{\beta} \left(\frac{j\omega + \frac{1}{\tau}}{j\omega + \frac{1}{\beta\tau}} \right)$$

Phase angle,

$$\phi = \tan^{-1} \omega\tau - \tan^{-1} \beta\omega\tau$$

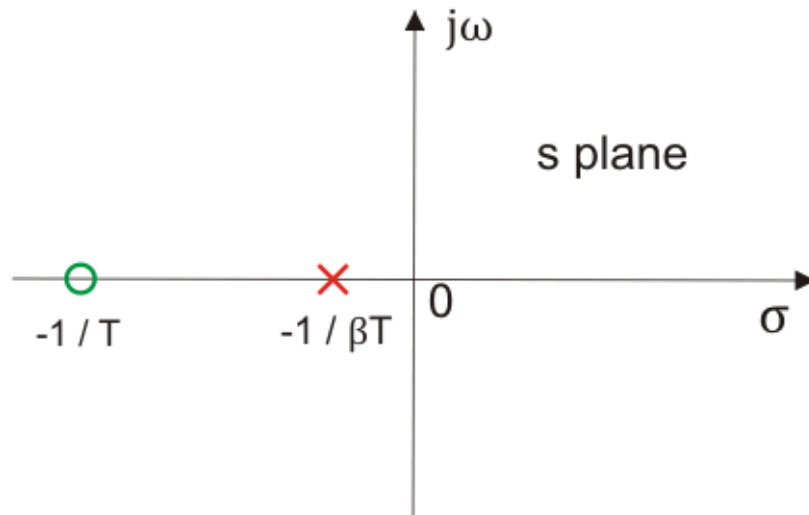

Figure 5.2.2 Pole-zero plot of lag compensator

[Source: "Control Systems" by A Nagoor Kani, Page: 4.65]

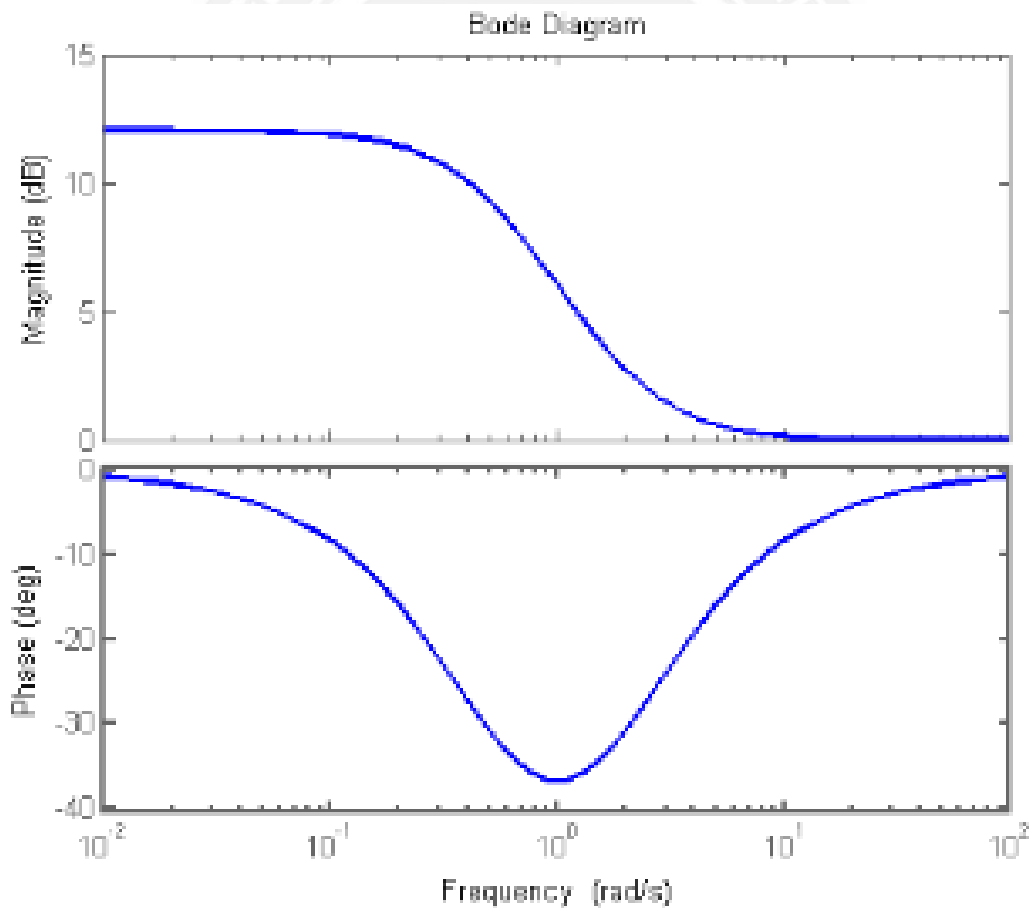

Figure 5.2.3 Bode plot of lag compensator

[Source: "Control Systems" by A Nagoor Kani, Page: 4.67]

The phase of the output sinusoidal signal is equal to the sum of the phase angles of input sinusoidal signal and the transfer function. So, in order to produce the phase lag at the output of this compensator, the phase angle of the transfer function should be negative. This will happen when $\beta > 1$.

Effect of Phase Lag Compensation

1. Gain crossover frequency increases.
2. Bandwidth decreases.
3. Phase margin will be increase.
4. Response will be slower before due to decreasing bandwidth, the rise time and the settling time become larger.

Advantages of Phase Lag Compensation

1. Phase lag network allows low frequencies and high frequencies are attenuated.
2. Due to the presence of phase lag compensation the steady state accuracy increases.

Disadvantages of Phase Lag Compensation

1. Due to the presence of phase lag compensation the speed of the system decreases.

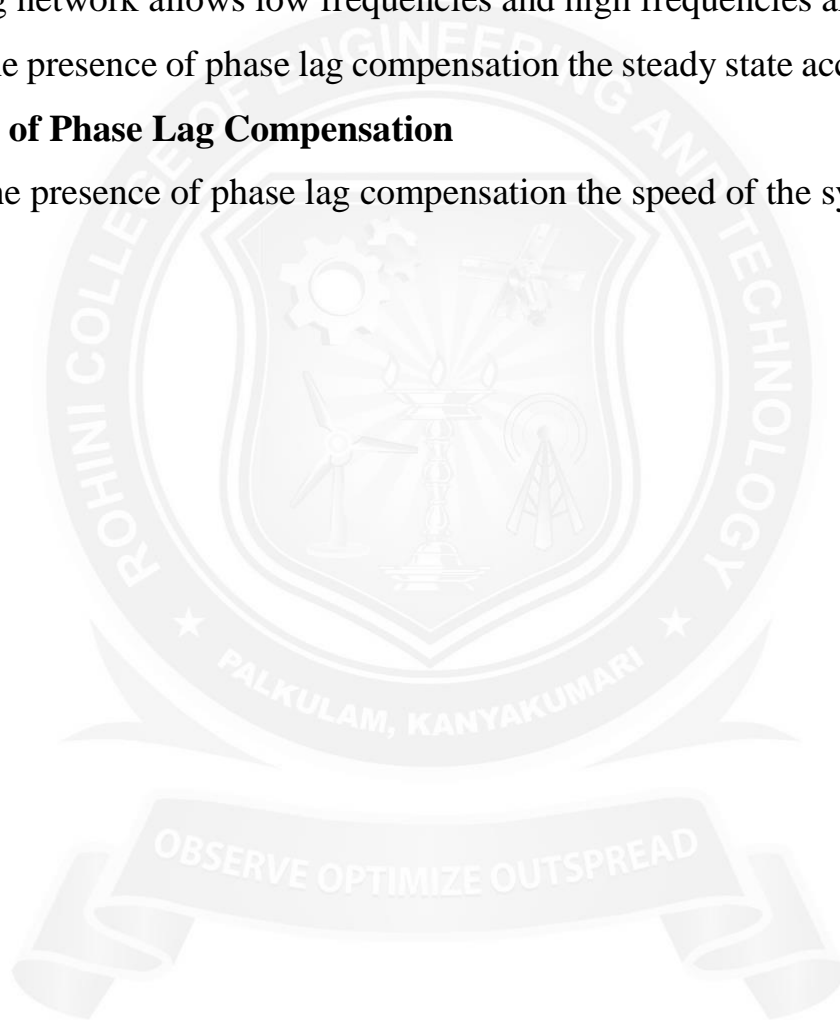

EFFECT OF LEAD COMPENSATION ON FREQUENCY RESPONSE

The lead compensator is an electrical network which produces a sinusoidal output having phase lead when a sinusoidal input is applied. The lead compensator circuit in the 's' domain is shown in the following figure. Lead compensator are used to improve the transient response of a system.

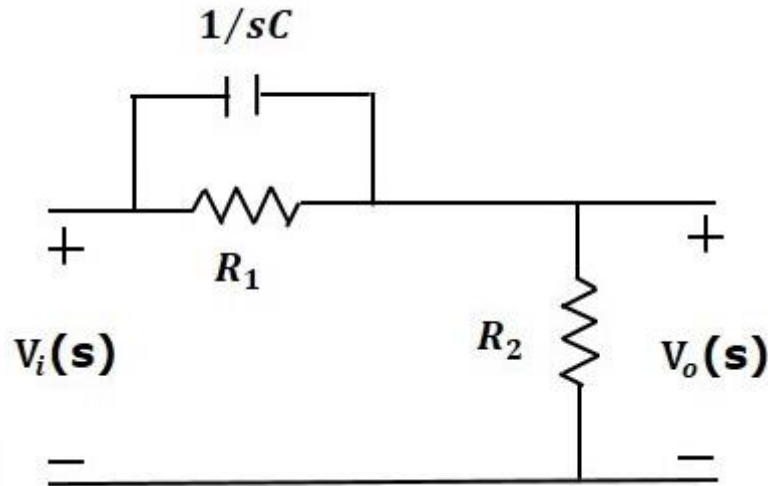

Figure 5.2.4 Electrical lead compensator

[Source: "Control Systems" by A Nagoor Kani, Page: 4.70]

Taking $i_2=0$ and applying Laplace Transform, we get,

$$\frac{V_o(s)}{V_i(s)} = \frac{R_2(R_1Cs + 1)}{R_1 + R_2 + R_2R_1Cs}$$

$$\frac{V_o(s)}{V_i(s)} = \alpha \left(\frac{\tau s + 1}{\alpha\tau s + 1} \right)$$

$$\tau = R_1C$$

$$\alpha = \frac{R_2}{R_1 + R_2}$$

$$\alpha < 1$$

$$\text{Pole, } s = -\frac{1}{\alpha\tau}$$

$$\text{Zero, } s = -\frac{1}{\tau}$$

Let $s = j\omega$,

$$\frac{V_o(j\omega)}{V_i(j\omega)} = \alpha \left(\frac{\tau j\omega + 1}{\alpha\tau j\omega + 1} \right)$$

Phase angle,

$$\phi = \tan^{-1} \omega\tau - \tan^{-1} \alpha\omega\tau$$

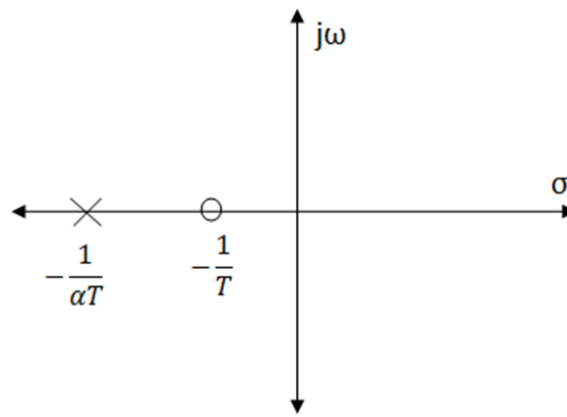

Figure 5.2.5 Pole-zero plot of lead compensator

[Source: "Control Systems" by A Nagoor Kani, Page: 4.69]

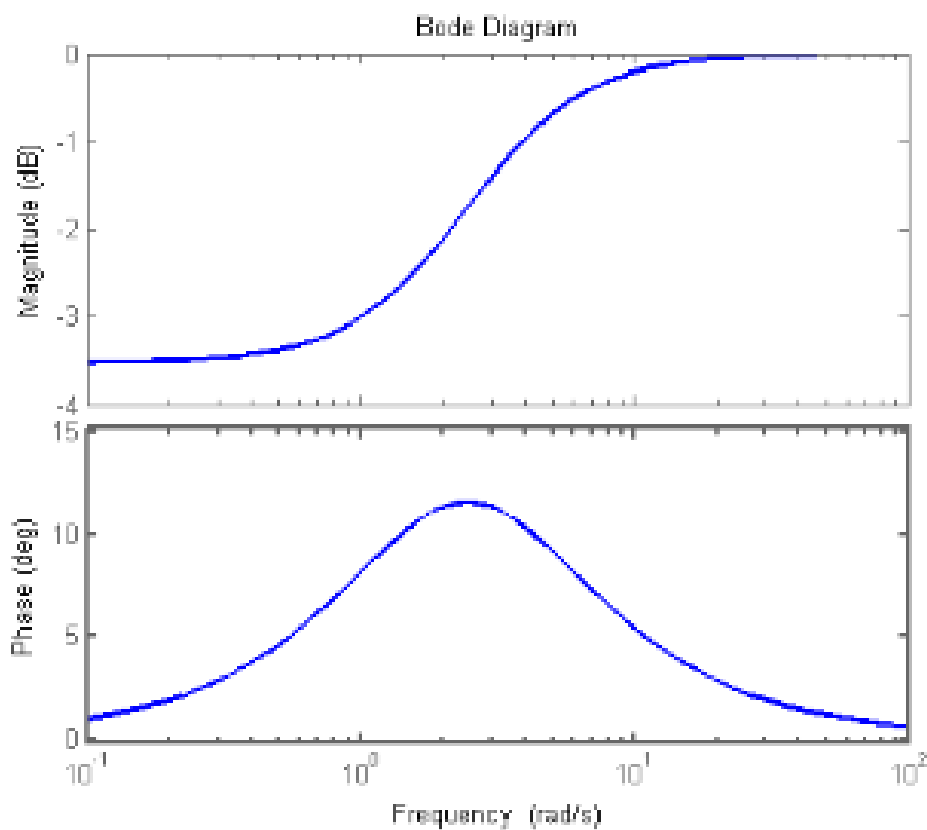

Figure 5.2.6 Bode plot of lead compensator

[Source: "Control Systems" by A Nagoor Kani, Page: 4.71]

The phase of the output sinusoidal signal is equal to the sum of the phase angles of input sinusoidal signal and the transfer function. So, in order to produce the phase lead at the output of this compensator, the phase angle of the transfer function should be positive. This will happen when $0 < \alpha < 1$. Therefore, zero will be nearer to origin in pole-zero configuration of the lead compensator.

Bode plot of lead compensator

Maximum phase lead occurs at

$$\omega_m = \frac{1}{\tau\sqrt{\alpha}}$$

Let Φ_m = maximum phase lead

$$\sin \phi_m = \frac{1 - \alpha}{1 + \alpha}$$

$$\alpha = \frac{1 - \sin \phi_m}{1 + \sin \phi_m}$$

Magnitude at maximum phase lead

$$|G_c(j\omega)| = \frac{1}{\sqrt{\alpha}}$$

Effect of Phase Lead Compensation

1. The velocity constant K_v increases.
2. The slope of the magnitude plot reduces at the gain crossover frequency so that relative stability improves and error decrease due to error is directly proportional to the slope.
3. Phase margin increases.
4. Response becomes faster.

Advantages of Phase Lead Compensation

1. Due to the presence of phase lead network the speed of the system increases because it shifts gain crossover frequency to a higher value.
2. Due to the presence of phase lead compensation maximum overshoot of the system decreases.

Disadvantages of Phase Lead Compensation

1. Steady state error is not improved.

EFFECT OF LAG-LEAD COMPENSATION ON FREQUENCY RESPONSE

Lag-Lead compensator is an electrical network which produces phase lag at one frequency region and phase lead at other frequency region. It is a combination of both the lag and the lead compensators. The lag-lead compensator circuit in the 's' domain is shown in the following figure.

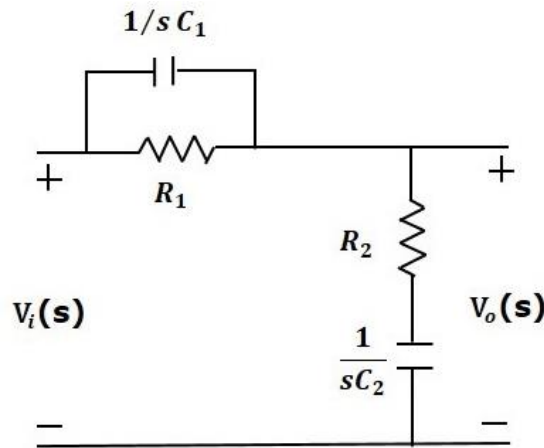

Figure 5.2.7 Electrical lag-lead compensator

[Source: "Control Systems" by A Nagoor Kani, Page: 4.73]

This circuit looks like both the compensators are cascaded. So, the transfer function of this circuit will be the product of transfer functions of the lead and the lag compensators.

$$\frac{V_o(s)}{V_i(s)} = \beta \left(\frac{\tau_1 s + 1}{\beta \tau_1 s + 1} \right) \frac{1}{\alpha} \left(\frac{s + \frac{1}{\tau_2}}{s + \frac{1}{\alpha \tau_2}} \right)$$

We know, $\alpha\beta=1$

$$\frac{V_o(s)}{V_i(s)} = \left(\frac{s + \frac{1}{\tau_1}}{s + \frac{1}{\beta \tau_1}} \right) \left(\frac{s + \frac{1}{\tau_2}}{s + \frac{1}{\alpha \tau_2}} \right)$$

where,

$$\tau_1 = R_1 C_1$$

$$\tau_2 = R_2 C_2$$

Advantages of Phase Lag Lead Compensation

1. Due to the presence of phase lag-lead network the speed of the system increases because it shifts gain crossover frequency to a higher value.
2. Due to the presence of phase lag-lead network accuracy is improved.

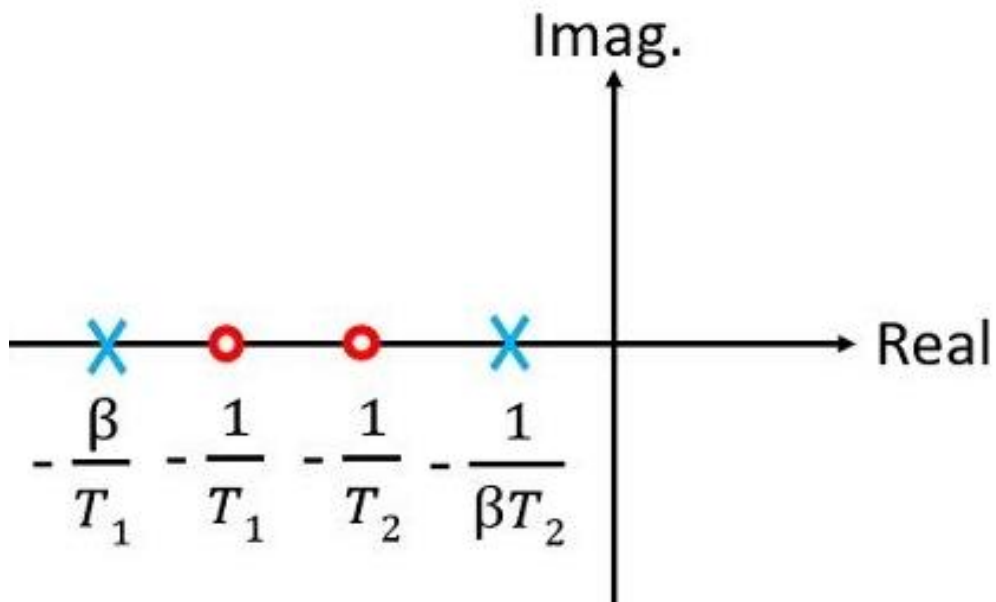

Figure 5.2.8 Pole-zero plot of lag-lead compensator

[Source: "Control Systems" by A Nagoor Kani, Page: 4.73]

