

## STATOR RESISTANCE STARTER

In order to apply the reduced voltage to the stator of the induction motor, three resistances are added in series with each phase of the stator winding. Initially the resistances are kept maximum in the circuit. Due to its large voltage gets dropped across the resistances. Hence a reduced voltage gets applied to the stator which reduces the high starting current. The schematic diagram showing stator resistances is shown in the Fig.4.1.

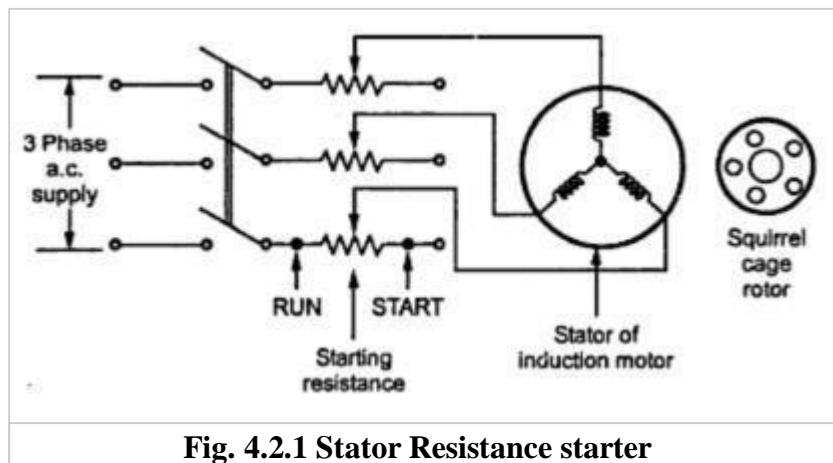

Fig. 4.2.1 Stator Resistance starter

When the motor starts running, the resistances are gradually cut-off from the stator circuit. When the resistances are entirely removed from the stator circuit i.e. rheostats in RUN position then rated voltage gets applied to the stator. Motor runs with normal speed.

The starter is simple in construction and cheap. It can be used for both star and delta connected stator. But there are large power losses due to resistances. Also the starting torque of the motor reduces due to reduced voltage applied to the stator.

### Relation between $T_{st}$ and $T_{F.L.}$

We know,  $P_2 = T \times \omega_s$

where T is torque produced and  $P_2$  is the rotor input at  $N_s$ .

$$\therefore T \propto P_2$$

But  $P_2 = P_c/s$  where  $P_c =$  Total copper loss

$$= (3I^2 R_2)/s_2$$

$$\therefore T \propto I_{2r}^2 / s$$

But rotor current  $I_{2r}$  and stator current are related to each other through transformer action.

$$\therefore T \propto I_1^2 / s \quad \text{where } I_1 = \text{Stator current}$$

At start,  $s = 1$ ,  $T = T_{st}$  and  $I_1 = I_{st}$

$$\therefore T_{st} \propto I_{st}^2 \quad \dots\dots(1)$$

When stator resistance starter is used, the factor by which stator voltage reduces is say  $x < 1$ . The starting current is proportional to this factor  $x$ . So if  $I_{sc}$  is the normal current drawn under full rated voltage condition at start then,

$$I_{st} = x I_{sc} \dots\dots\dots(2)$$

$$\therefore T_{st} \propto (x I_{sc})^2 \dots\dots\dots(3)$$

$$\text{But } T_{F.L.} \propto (I_{F.L.})^2 / s_f$$

Taking ratio of (3) and (4),

where  $s_f = \text{Full load slip}$  (4)

$$\frac{T_{st}}{T_{F.L.}} = x^2 \left( \frac{I_{sc}}{I_{F.L.}} \right)^2 s_f$$

**Note :** As  $x < 1$ , it can be seen that the starting torque reduces by the fraction  $x^2$  due to the stator resistance starter.

## AUTO TRANSFORMER STARTER

A three phase star connected autotransformer can be used to reduce the voltage applied to the stator. Such a starter is called an autotransformer starter. The schematic diagram of autotransformer starter. The schematic diagram of autotransformer starter is shown in the Fig..1.

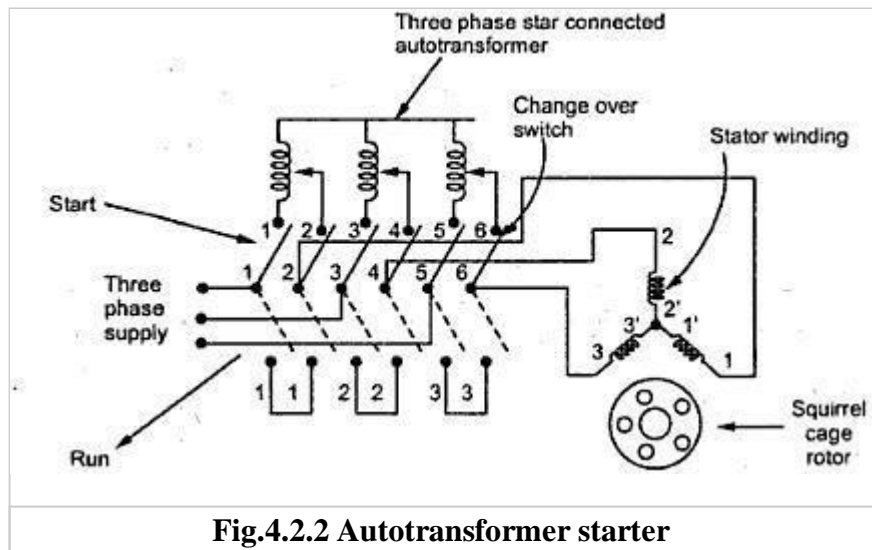

It consists of a suitable change over switch.

When the switch is in the start position, the stator winding is supplied with reduced voltage. This can be controlled by tappings provided with autotransformer.

The reduction in applied voltage by the fractional percentage tappings  $x$ , used for an autotransformer is shown in the Fig. 4.2.2

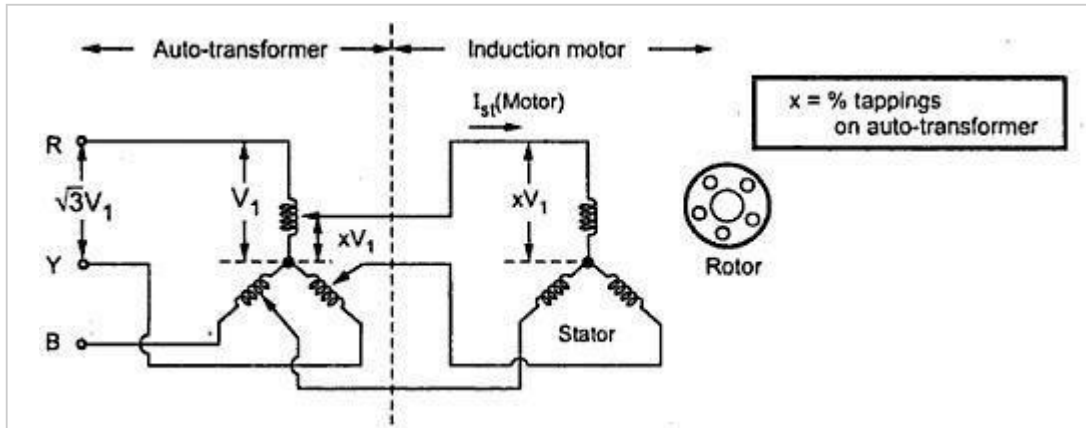

**Fig.4.2.3 Use of autotransformer to reduce voltage at start**

When motor gathers 80% of the normal speed, the change over switch is thrown into run position.

Due to this, rated voltage gets applied to stator winding. The motor starts rotating with normal speed. Changing of switch is done automatically by using relays. The power loss is much less in this type of starting. It can be used for both star and delta connected motors. But it is expensive than stator resistance starter.

1.1 Relation between  $T_{st}$  and  $T_{FL}$ .

Let x be the fractional percentage tapplings used for an autotransformer to apply reduced voltage to the stator.

So if,  $I_{sc}$  = Starting motor current at rated voltage

and  $I_{st}$  = Starting motor current with starter

then  $I_{st} = x I_{sc}$  .....Motor side ..... (1)

But there is exists a fixed ratio between starting current drawn from supply  $I_{st}(\text{supply})$  and starting moor current  $I_{st}(\text{motor})$  due to autotransformer, as shown in the Fig.4.3.

Autotransformer ratio  $x = I_{st}(\text{supply}) / I_{st}(\text{motor})$

$$I_{st}(\text{supply}) = x I_{st}(\text{motor}) \dots\dots\dots (2)$$

Substituting  $I_{st}(\text{motor})$  from equation (1),

$$\therefore I_{st}(\text{supply}) = x \cdot x I_{sc} = x^2 I_{sc}$$

Now  $T_{st} \propto I_{st}^2$  (motor)  $\propto x^2 I^2$ ..... (3)

and  $T_{F.L.} \propto (I_{F.L.})^2/s_f$

$$\therefore \frac{T_{st}}{T_{F.L.}} = x^2 \left[ \frac{I_{sc}}{I_{F.L.}} \right]^2 \times s_f$$

**Note :** Thus starting torque reduces by  $x^2$  where  $x$  is the transformer ratio.

Example : A squirrel cage induction motor has a full load slip of 5%. The motor starting current at rated voltage is 6 times its full load current. Find the tapping on the autotransformer starter which would give full load torque at start. What would then be the supply starting current ?

Solution : Starting current at rated voltage =  $I_{sc}$

$\therefore I_{sc} = 6 I_{F.L.}$  and  $s_f = 5\% = 0.05$

Let  $x =$  Tapping on autotransformer

$T_{F.L.} = T_{st}$

$\therefore$

$$\frac{T_{st}}{T_{F.L.}} = x^2 \left[ \frac{I_{sc}}{I_{F.L.}} \right]^2 \times s_f$$

$1 = x^2 (6/1)^2 \times 0.05$

$x = 0.7453$

Thus 74.53% tapping is required

Now  $I_{st}$  (supply) =  $x I_{st}$  (motor) =  $x (xI_{sc}) = x^2 I_{sc}$   
 $= x^2 \times 6 = 3.33 I_{F.L.}$

Thus supply starting current is 3.33 times the full load current.